

EXPERIENCE



A New Level of
Modular Protection From
L&T Electrical & Automation



10 kA Modular Devices in Our Range

ABOUT US

L&T Electrical & Automation (E&A) is a market leader for electrical distribution, monitoring and control solutions in the low voltage category.

Popular among customers as L&T Switchgear, E&A offers a wide range of low and medium voltage switchgear, motor starters, electrical systems, industrial automation, building electrical solutions, energy management solutions, electrical modernization solutions and metering solutions. Its products and solutions cater to key sectors of economy like industries, utilities, infrastructure, building and agriculture.

E&A's manufacturing operations at Navi Mumbai, Ahmednagar, Vadodara, Coimbatore and Mysuru in India adhere to global practices of excellence and receive support from well-equipped in-house design and development centres as well as tooling facilities that contribute to precision in manufacturing.





L&T Electrical & Automation (E&A) Modular Devices

E&A's range of modular devices offer MCB, RCCB, and Isolator for final distribution of electrical power. E&A's products are known for reliability, functionality and ease of use.



E&A modular devices
spell world class

E&A products conform to relevant global standards viz. IEC, EN. They also have BIS and CE marking, as well as CB and KEMA certification.



EXORA

E&A offers its new range of Modular Devices – **EXORA** – to ensure a safe environment around you. Protection and Control devices offered in this range provide safety at your home and at your workplace. Salient features of this range – Quick Break Mechanism, True Contact Position Indicator, Energy Limitation Class 3 – enhance safety of human lives and precious belongings.

Further, Low Watt loss of these products reduces the amount of electricity consumed and results in low electricity expense. Features such as Biconnect and Two Position DIN Clip provide flexibility and ease of operation.



MODULAR DEVICES

1. Miniature Circuit Breakers (MCBs)



1

2. Residual Current Circuit Breakers (RCCBs)



7

3. Isolators



11

Technical Index

16



MCB (10kA)

Miniature Circuit Breaker



The MCB is a vital protection device. It is essential in every electrical installation to safeguard both your life and valuable property against short-circuit and overload.

Features and Benefits

- Conforms to IS/IEC 60898-1, IEC 60947-2
- Characteristic Tripping curves B, C & D
- Energy limiting Class 3 allows low let-through energy in the system
- Unique patented design gives both label holder and true contact indication facility for individual poles
- Low watt loss – almost 50% of the values prescribed by IEC 60898-1 saves energy
- Trip free mechanism to ensure maximum safety
- Design based on advanced current limiting hammer trip mechanism ensures quick breaking
- No line load bias gives flexibility for incomer supply termination on either sides
- Connection - Biconnect on both sides of MCB
- Accessories – wide range of accessories like aux contact, trip alarm contact and shunt release
- DC MCB as per IEC 60947-2 : Rated Voltage: 130/250 V DC (SP/DP), 250/500 V DC (SP/DP)
- CE conformity

Terminals suitable up to 35 sq mm cable



Connection - Biconnect on both sides of MCB



2-position DIN-Rail clip - ease of installation

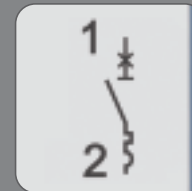

Suitable for isolation - Safe to do downstream maintenance



Label Holder



True Contact Indication - enhanced safety



IP-20 Finger-proof terminals - eliminate chances of accidental contact

Technical Specifications – MCB



Specification	IS / IEC 60898-1, IEC 60947-2
Current Rating	0.5 to 63A
Tripping Characteristic	B, C and D curve
Breaking Capacity	IS/IEC 60898-1* : 10 kA
	IEC 60947-2 } 15kA (0.5A to 40A) (C Curve) } 10kA (50A & 63A)
Rated Voltage	240 / 415 V AC
Frequency	50 & 60 Hz
Rated Impulse Voltage	4 kV
Rated Insulation Voltage	500 V
Minimum Operating Voltage	24 V AC
Degree of Protection	IP 20
Applied Connection Torque	4 Nm
Operating Temperature	- 25° C to + 70° C
Calibration Temperature	30° C
Termination Capacity	35 mm ² (Rigid) 25 mm ² (Flexible)
Mechanical Life (operating cycles)	>100,000
Electrical Life (operating cycles)	20,000 (cos Ø = 0.85 to 0.9) 6A to 32A
	10,000 (cos Ø = 0.85 to 0.9) for 40A to 63A
Mounting Position	Horizontal/Vertical/Flat
Mounting	Snap fixing on standard profile 35 X 7.5mm DIN-Rail as per EN 50022

* 50A & 63A D-Curve : IEC 60898-1

Dimensions

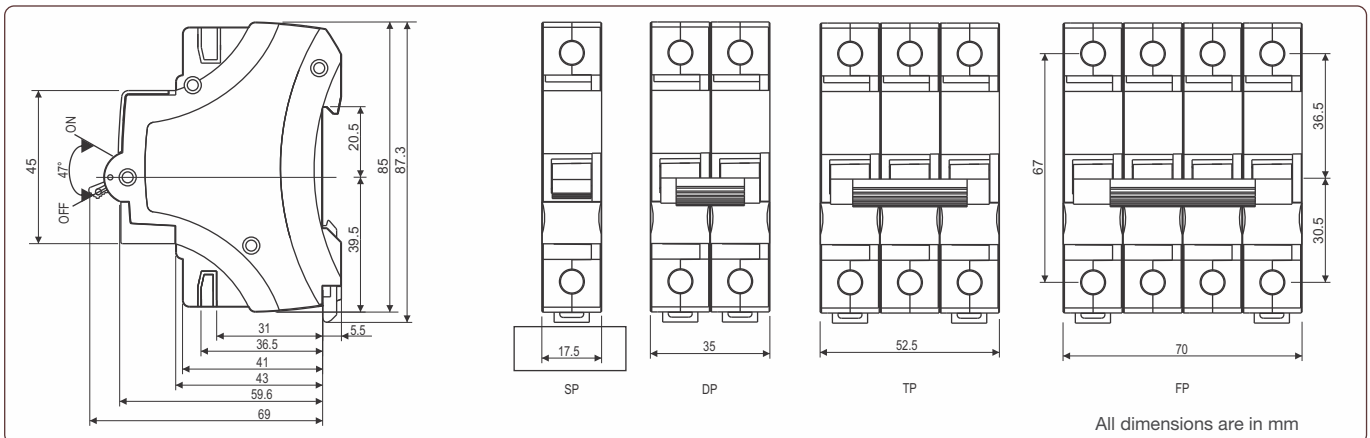

Technical Specifications – DC MCB



Specification	DC MCBs - IEC 60947-2	
Current Rating	0.5 to 63A	0.5 to 40A
Tripping Characteristic	C curve	C curve
Breaking Capacity	6kA	10kA
Rated Voltage	130V DC - Single Pole 250V DC - Double Pole	250V DC - Single Pole 500V DC - Double Pole
Supply	Polarity independent	Polarity dependent*
Rated Impulse Voltage	4 kV	
Rated Insulation Voltage	500 V	
Minimum Operating Voltage	24 V DC	
Degree of Protection	IP 20	
Applied Connection Torque	4 Nm	
Operating Temperature	- 25° C to + 70° C	
Calibration Temperature	30° C	
Termination Capacity	35 mm ² (Rigid) 25 mm ² (Flexible)	
Mechanical Life (operating cycles)	>100,000	
Electrical Life (operating cycles)	3000 (L/R=2mS)	
Mounting Position	Horizontal/Vertical/Flat	
Mounting	Snap fixing on standard profile 35 X 7.5mm DIN-Rail as per EN 50022	

*Refer connection diagram below for connection

Dimensions

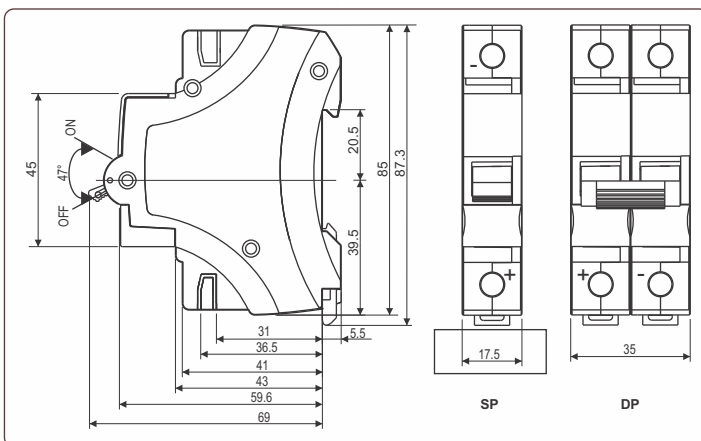

Connection diagram for 250 / 500 V DC MCBs

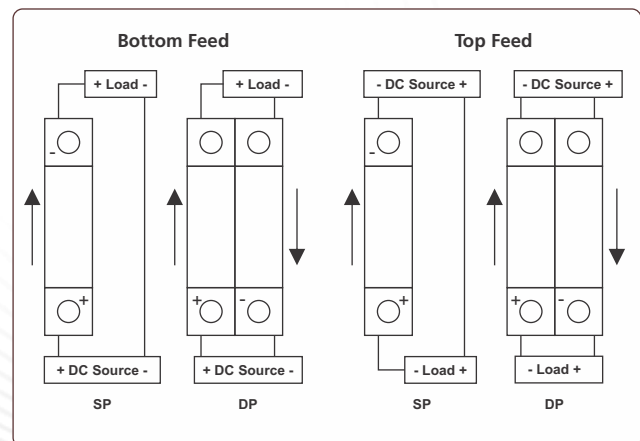

Single-Pole (SP)



Current Rating (In)	Modules 1 Mod=17.5mm	B-Curve Cat. Nos.	C-Curve Cat. Nos.	D-Curve Cat. Nos.	DC MCBs Cat. Nos. (130 V)	DC MCBs Cat. Nos. (250 V)
0.5A	1	-	BB10E50C	BB10E50D	BB10E5DC	BJ10E5DC
1A	1	-	BB10010C	BB10010D	BB1001DC	BJ1001DC
2A	1	-	BB10020C	BB10020D	BB1002DC	BJ1002DC
3A	1	-	BB10030C	BB10030D	BB1003DC	BJ1003DC
4A	1	-	BB10040C	BB10040D	BB1004DC	BJ1004DC
6A	1	BB10060B	BB10060C	BB10060D	BB1006DC	BJ1006DC
10A	1	BB10100B	BB10100C	BB10100D	BB1010DC	BJ1010DC
16A	1	BB10160B	BB10160C	BB10160D	BB1016DC	BJ1016DC
20A	1	BB10200B	BB10200C	BB10200D	BB1020DC	BJ1020DC
25A	1	BB10250B	BB10250C	BB10250D	BB1025DC	BJ1025DC
32A	1	BB10320B	BB10320C	BB10320D	BB1032DC	BJ1032DC
40A	1	BB10400B	BB10400C	BB10400D	BB1040DC	BJ1040DC
50A	1	BB10500B	BB10500C	BB10500D	BB1050DC	-
63A	1	BB10630B	BB10630C	BB10630D	BB1063DC	-

Double-Pole (DP)



Current Rating (In)	Modules 1 Mod=17.5mm	B-Curve Cat. Nos.	C-Curve Cat. Nos.	D-Curve Cat. Nos.	DC MCBs Cat. Nos. (250 V)	DC MCBs Cat. Nos. (500 V)
0.5A	2	-	BB20E50C	BB20E50D	BB20E5DC	BJ20E5DC
1A	2	-	BB20010C	BB20010D	BB2001DC	BJ2001DC
2A	2	-	BB20020C	BB20020D	BB2002DC	BJ2002DC
3A	2	-	BB20030C	BB20030D	BB2003DC	BJ2003DC
4A	2	-	BB20040C	BB20040D	BB2004DC	BJ2004DC
6A	2	BB20060B	BB20060C	BB20060D	BB2006DC	BJ2006DC
10A	2	BB20100B	BB20100C	BB20100D	BB2010DC	BJ2010DC
16A	2	BB20160B	BB20160C	BB20160D	BB2016DC	BJ2016DC
20A	2	BB20200B	BB20200C	BB20200D	BB2020DC	BJ2020DC
25A	2	BB20250B	BB20250C	BB20250D	BB2025DC	BJ2025DC
32A	2	BB20320B	BB20320C	BB20320D	BB2032DC	BJ2032DC
40A	2	BB20400B	BB20400C	BB20400D	BB2040DC	BJ2040DC
50A	2	BB20500B	BB20500C	BB20500D	BB2050DC	-
63A	2	BB20630B	BB20630C	BB20630D	BB2063DC	-

Three-Pole (TP)



Current Rating (In)	Modules 1 Mod= 17.5mm	B-Curve Cat. Nos.	C-Curve Cat. Nos.	D-Curve Cat. Nos.
0.5A	3	-	BB30E50C	BB30E50D
1A	3	-	BB30010C	BB30010D
2A	3	-	BB30020C	BB30020D
3A	3	-	BB30030C	BB30030D
4A	3	-	BB30040C	BB30040D
6A	3	BB30060B	BB30060C	BB30060D
10A	3	BB30100B	BB30100C	BB30100D
16A	3	BB30160B	BB30160C	BB30160D
20A	3	BB30200B	BB30200C	BB30200D
25A	3	BB30250B	BB30250C	BB30250D
32A	3	BB30320B	BB30320C	BB30320D
40A	3	BB30400B	BB30400C	BB30400D
50A	3	BB30500B	BB30500C	BB30500D
63A	3	BB30630B	BB30630C	BB30630D

Four-Pole (FP)



Current Rating (In)	Modules 1 Mod= 17.5mm	B-Curve Cat. Nos.	C-Curve Cat. Nos.	D-Curve Cat. Nos.
0.5A	4	-	BB40E50C	BB40E50D
1A	4	-	BB40010C	BB40010D
2A	4	-	BB40020C	BB40020D
3A	4	-	BB40030C	BB40030D
4A	4	-	BB40040C	BB40040D
6A	4	BB40060B	BB40060C	BB40060D
10A	4	BB40100B	BB40100C	BB40100D
16A	4	BB40160B	BB40160C	BB40160D
20A	4	BB40200B	BB40200C	BB40200D
25A	4	BB40250B	BB40250C	BB40250D
32A	4	BB40320B	BB40320C	BB40320D
40A	4	BB40400B	BB40400C	BB40400D
50A	4	BB40500B	BB40500C	BB40500D
63A	4	BB40630B	BB40630C	BB40630D

Auxiliaries and Accessories

10 kA MCBs



E&A MCBs can be fitted with a wide range of accessories like the auxiliary contact, shunt release and trip alarm contact.

Auxiliary & Accessories for 10kA MCBs

Description	Cat. Nos.
Auxiliary Contact – 240V AC, 6A (1NO+1NC), 1/2 module	BZA11006
Shunt Release – 240V AC, 1 module	BZS00240
Trip Alarm Contact - 240V AC, 6A (1NO + 1NC), 1/2 module	BZT11006

RCCB

Residual Current Circuit Breaker



Residual Current Circuit Breakers provide protection against earth leakage fault. They ensure safety of human life in case of earth leakage fault and protection against electric shock.

Features and Benefits

- Conforms to IS 12640-(Part 1), IEC 61008-1
- Rated conditional short-circuit current 10 kA
- E&A RCCBs are available in DP and FP versions from 25A to 100A ratings with 30mA, 100mA and 300mA sensitivity
- Truly current operated – operation even at low voltage
- Operates on Core Balance Current Transformer (CBCT) principle
- Neutral advance mechanism ensures complete protection
- Finger-proof terminal (IP 20)
- Connection - Biconnect on both sides of RCCB

Protection Devices – RCCB



Finger-proof terminal – IP 20



Connection – Biconnect suitable for Busbar and / or wire up to 50 sq mm



Test button – Facilitates to check healthiness of device by creating an artificial electrical fault



Combi-head screws – allows use of standard as well as Philips head screwdriver

Technical Specifications – RCCB

Specification	IS 12640 – Part 1 / IEC 61008-1
RCCB Type	AC
Rated Current (I _n) – A	25, 40, 63, 100
Operating Sensitivity – mA	30, 100, 300
No. of Poles	2 and 4 Pole
Rated Voltage	240/415 V AC
Rated Frequency	50Hz & 60Hz*
Rated Insulation Voltage	500 V
Rated Impulse Withstand Voltage	4 kV
Rated Conditional Short-Circuit Current	10 kA
Rated Residual Making and Breaking Capacity	1 kA
Degree of Protection	IP 20
Termination Capacity	50 mm ² (Rigid) 35 mm ² (Flexible)
Operating Temperature	-5°C to + 55°C
Mechanical Life (operating cycles)	20,000
Electrical Life (up to 63A) (operating cycles)	10,000
Mounting Arrangement	Snap-fit on 35 mm DIN-Rail

*For 60Hz requirement, Please contact nearest sales branch

Note : For back-up short circuit protection device, please refer to page no. 27

Dimensions

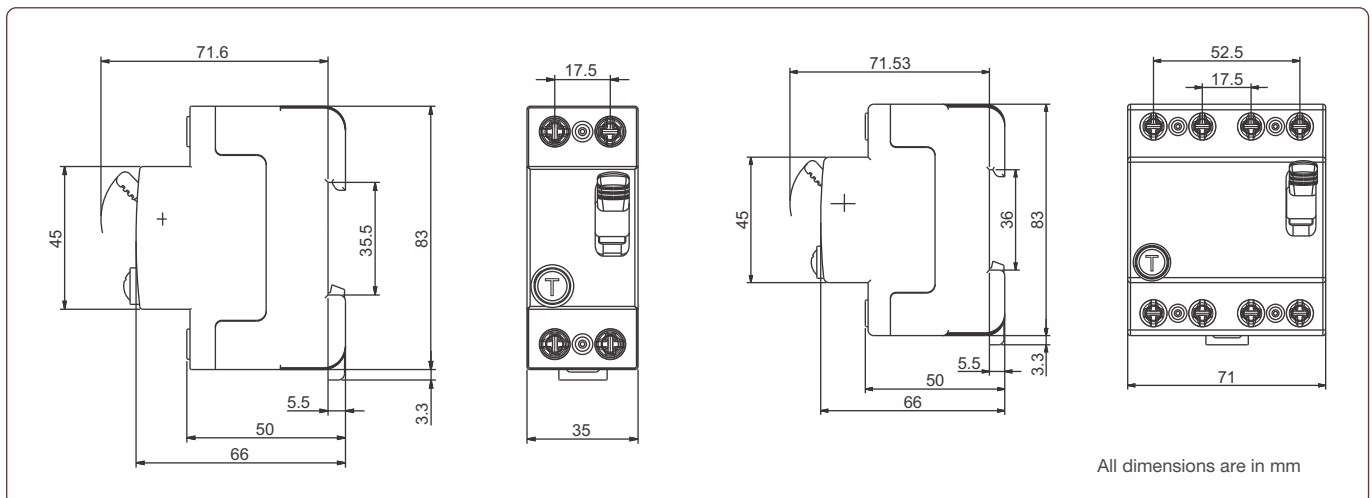

Current Rating (In)	Sensitivity	Modules 1 Mod= 17.5mm	Cat Nos.
25A	30mA	2	BG202503
	100mA	2	BG202510
	300mA	2	BG202530
40A	30mA	2	BG204003
	100mA	2	BG204010
	300mA	2	BG204030
63A	30mA	2	BG206303
	100mA	2	BG206310
	300mA	2	BG206330
100A	30mA	2	BG210003
	100mA	2	BG210010
	300mA	2	BG210030

Double-Pole (DP)



Current Rating (In)	Sensitivity	Modules 1 Mod= 17.5mm	Cat Nos.
25A	30mA	4	BG402503
	100mA	4	BG402510
	300mA	4	BG402530
40A	30mA	4	BG404003
	100mA	4	BG404010
	300mA	4	BG404030
63A	30mA	4	BG406303
	100mA	4	BG406310
	300mA	4	BG406330
100A	30mA	4	BG410003
	100mA	4	BG410010
	300mA	4	BG410030

Four-Pole (FP)



ISOLATORS



Isolators are used in electrical installations to make, carry and break circuit current. The Isolator ensures that the circuit remains completely isolated i.e. there will be no current at the load side even if the impulse voltage appears when the isolator is OFF.

Features and Benefits

- Conforms to EN/IEC 60947-3
- Suitable for AC22-A utilization category
- Available in DP, TP and FP versions in 40A, 63A, 80A and 100A ratings
- Easy mounting due to two-position DIN-Rail clip
- Combi-head screws – allows use of multiple screwdrivers
- True contact indication – enhances safety
- CE and KEMA certified

Connection - Biconnect
Terminals suitable up to
35 sq mm cable



2 position DIN-Rail clip
– ease of installation



True Contact
Indication –
enhanced safety



IP-20 Finger-proof terminals – eliminate
chances of accidental contact

Technical Specifications – ISOLATORS

Specification	EN / IEC 60947 – 3
Rated Current (In)	40A, 63A, 80A, 100A
No. of Poles	2, 3 and 4
Rated Operational Voltage (AC)	240/415 V
Rated Frequency	50 Hz
Rated Insulation Voltage	500 V
Rated Impulse Voltage	4 kV
Utilization Category	AC 22A
Degree of Protection	IP 20
Termination Capacity	35 mm ² (Rigid) 25 mm ² (Flexible)
Operating Temperature	-5°C to + 50°C
Mounting Arrangement	Snap-fit on 35 mm DIN rail
Rated Short Time Withstand Current, I _{cw}	12 In , 1 sec

Dimensions

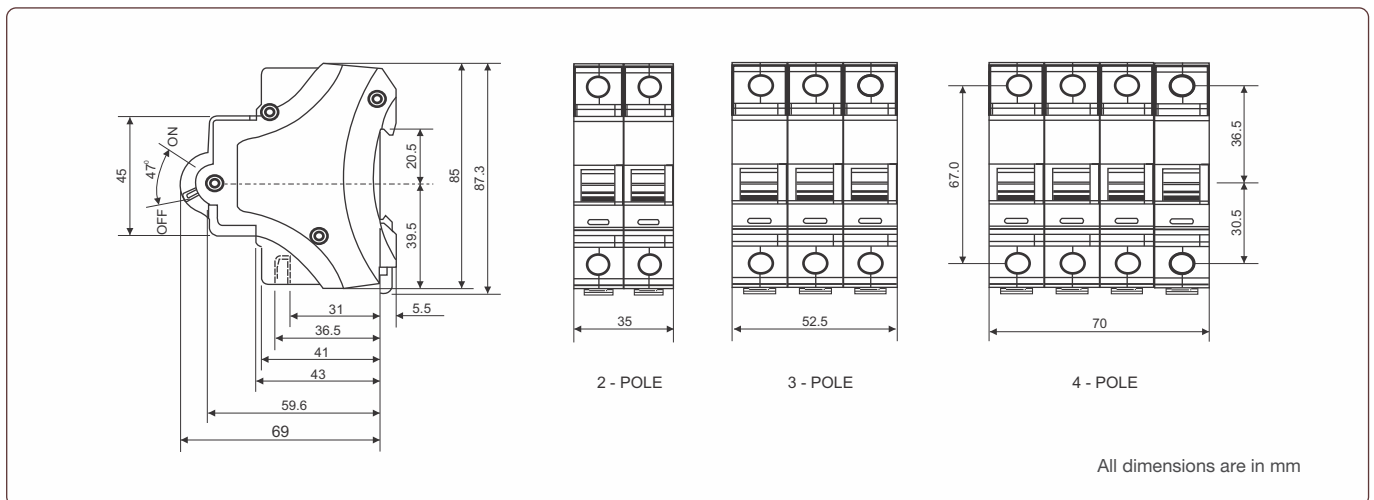

Double Pole (DP)



Current Rating (In)	Modules 1Mod = 17.5mm	Cat. Nos
40	2	BF204000
63	2	BF206300
80	2	BF208000
100	2	BF210000

Current Rating (In)	Modules 1Mod = 17.5mm	Cat. Nos.
40	3	BF304000
63	3	BF306300
80	3	BF308000
100	3	BF310000

Three Pole (TP)



Current Rating (In)	Modules 1Mod = 17.5mm	Cat. Nos.
40	4	BF404000
63	4	BF406300
80	4	BF408000
100	4	BF410000

Four Pole (FP)



Ingress Protection (IP)

The protection of enclosures against ingress of dirt or against the ingress of water is defined in IEC529 (BSEN60529:1991). Conversely, an enclosure which protects equipment against ingress of particles will also protect a person from potential hazards within that enclosure, and this degree of protection is also defined as a standard.

The degrees of protection are most commonly expressed as 'IP' followed by two numbers, e.g. IP65, where the numbers define the degree of protection.

1st Digit Protection against Human Contact/ Protection against Foreign Bodies

No special protection

With back of hand / large foreign bodies, diam. >50mm

With a finger / medium-sized foreign bodies, diam. >12.5mm

With tools and wires etc. with a thickness >2.5mm / small foreign bodies, diam. >2.5mm

With tools and wires etc. with a thickness >1mm / granular foreign bodies, diam. >1mm

Complete protection / dust protected

Complete protection / dust-proof

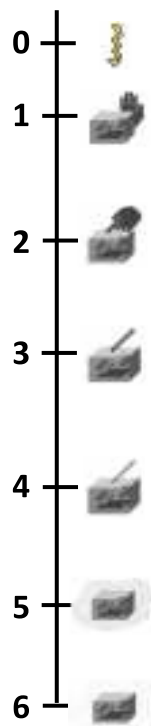

2nd Digit Protection against Water Ingress

No special protection

Water dripping vertically

Water dripping at an angle (up to 15 degrees from the vertical)

Spray water (any direction up to 60 degrees from the vertical)

Spray water from all directions

Water jets from a nozzle in all directions

High pressure jets

Temporary immersion

Permanent immersion

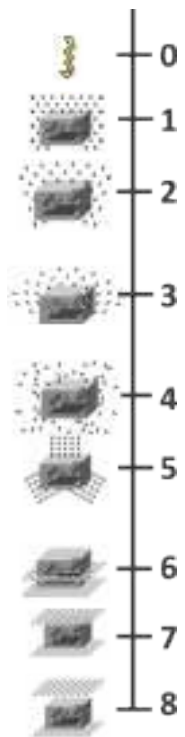

TECHNICAL INDEX

1. Basics of Electrical System and General Electrical Practices

- 1.1 Types of Faults
 - 1.2 Safety Requirements
-

2. Earthing Systems

- 2.1 Types of Earthing systems
 - 2.2 Comparison of Earthing systems
 - 2.3 Choice of Earthing
-

3. Miniature Circuit Breaker (MCB)

- 3.1 Selection of MCB
 - 3.2 Application of different curves
 - 3.3 Temperature de-rating chart
 - 3.4 Current-limiting and Energy-limiting class
 - 3.5 Important Definitions and Symbols of MCB
 - 3.6 Conditions for suitability for isolation as per IEC 60947-2
 - 3.7 MCB Characteristic Curves
 - 3.8 Watt loss table
-

4. Residual Current Devices

- 4.1 Danger of Human – Electrocutation
- 4.2 Working of residual current devices
- 4.3 Precautions for installation
- 4.4 Fault finding when RCCB trips
- 4.5 RCCBs : Domestic Installation

1. Basics of Electrical System and General Electrical Practices

1.1 Types of Faults

A fault can be defined as any abnormal flow of electric current, in an electric power system.

Types of faults

Faults can be broadly classified into two main areas.

- a. Active Fault
- b. Passive Fault

a. Active Fault

An 'Active' fault occurs when actual current flows from one phase conductor to another (phase-to-phase) or alternatively from one phase conductor to earth (phase-to-earth). This type of fault can also be further classified into two areas, namely the 'solid' fault and the 'incipient' fault.

Solid fault

The solid fault occurs as a result of an immediate complete breakdown of insulation. For example a pick struck an underground cable, bridging conductors etc.

Incipient fault

An incipient fault is a fault that starts from very small beginnings, say some partial discharge (excessive electronic activity often referred to as corona) in a void in the insulation, increasing and developing over an extended period, until such time as it burns away adjacent insulation, eventually running away and developing into a "solid" fault.

b. Passive Fault

Passive faults are not real faults in the true sense of the word, but are conditions that stress the system beyond its design capacity, so that ultimately active faults will occur. Examples of passive faults Overloading leading to overheating of insulation (deteriorating quality, reduced life and ultimate failure).

Overvoltage – stressing the insulation beyond its limits.
Under frequency – causing plant to behave incorrectly.
Power swings – generators going out-of-step or synchronism with each other.

1.2 Safety Requirements

Some of the important safety requirements in electrical installations in domestic dwellings are summarized below:

- a. All outlets for domestic electrical appliances shall be of three-pin socket type, the third socket being connected to the earth.
- b. All the single-pole switches shall be on phase or live conductor only.
- c. The electrical outlets for appliances in the bathrooms shall be away from the shower or sink.
- d. Wiring for power outlets in the kitchen shall be preferably done in metallic conduit wiring.
- e. The electrical outlets shall not be located above the gas stove.
- f. The clearance between the bottom-most point of the ceiling fan and the floor shall be not less than 2.4 m.
- g. The metallic body of the fan regulator if any, shall be earthed effectively.
- h. Earth leakage circuit-breaker at the intake of power supply at the consumer's premises shall be provided.

2. Earthing Systems

2.1 Types of Earthing systems

According to BS 7671 five types of earthing are specified.

- TT- Earthing system
- TN-S Earthing system
- TN-C system
- TN-C-S system
- IT-system

In the above systems,

T = Earth (from the French word *Terre*)

N = Neutral

S = Separate

C = Combined

I = Isolated

When designing an electrical installation, one of the first things to determine is the type of earthing system. The system will either be TN-S, TN-C-S Protective Multiple Earthing (PME) or TT for a low voltage supply given in accordance with the Electricity Safety, Quality and

Continuity Regulations 2002.

a. TT system – If the neutral of the source & protective earth (PE) conductor at the consumer end are earthed separately, the system is called TT system. The system is as shown in the figure.

With TT, the consumer must provide their own connection to earth, i.e. by installing a suitable earth electrode local to the installation. The circumstances in which a distributor may not provide a means of earthing for the consumer where the distributor cannot guarantee the earth connection back to the source, e.g. a low voltage overhead supply or where there is the likelihood of the earth wire either becoming somehow disconnected or even stolen.

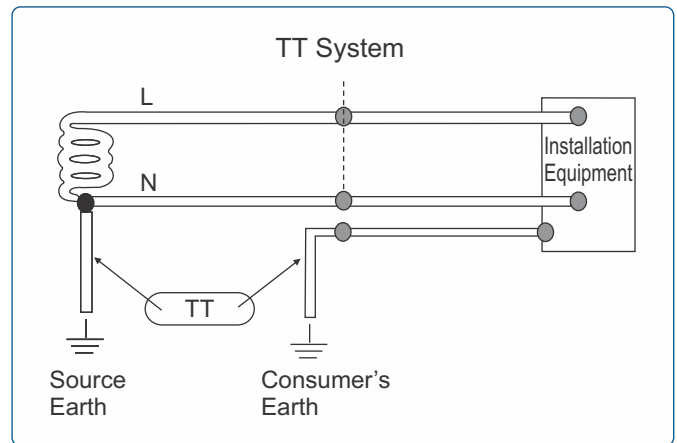

b. TN- S system

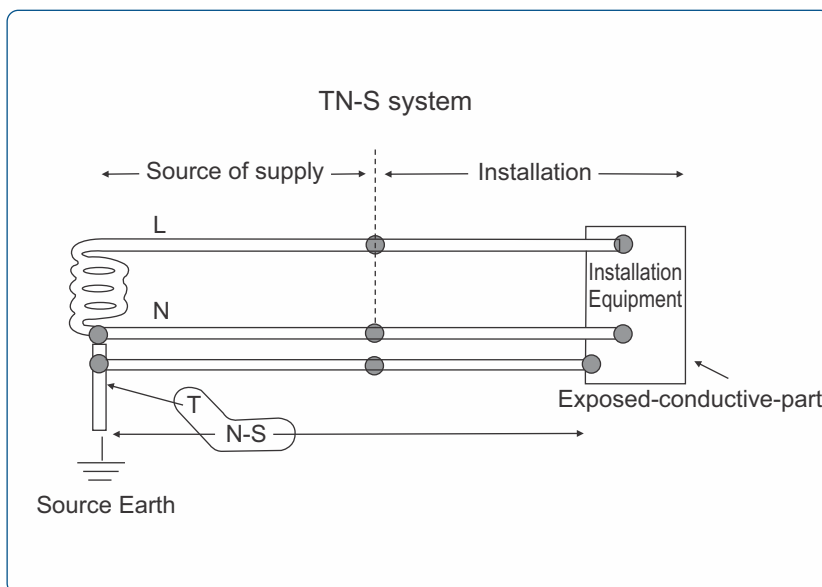

In this system, the N and PE neutral conductors are separate. PE and N conductors are mandatory for the circuits of cross-section less than 10 sq.mm.

A TN-S system has the neutral of the source of energy connected with earth at one point only, at or as near as is reasonably practicable to the source. The consumer's earthing terminal is typically connected to the metallic sheath or armour of the distributor's service cable into the

premises or to a separate protective conductor of, for instance, an overhead supply. Large consumers may have one or more HV/LV transformers dedicated to their installation and installed adjacent to or within their premises. In such situations, the usual form of system earthing is TN-S.

c. TN-C-S system

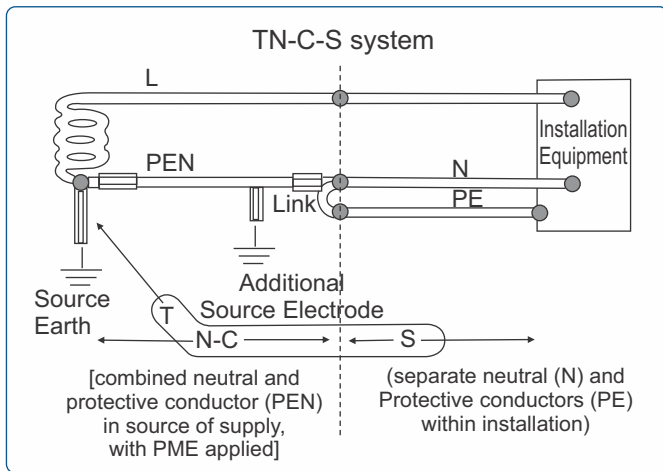

A TN-C-S system has the supply neutral conductor of a distribution main connected with earth at source and at intervals along its run. This is usually referred to as Protective Multiple Earthing (PME). With this arrangement the distributor's neutral conductor is also used to return earth fault currents arising in the consumer's installation safely to the source. To achieve this, the distributor will provide a consumer's earthing terminal which is linked to the incoming neutral conductor.

d. TN-C system

If the N and PE neutral conductors are one and the same (PEN) in the system than such a system is called a TN-C system. In this system RCD will trip in case of leakage only through human body. So this system is most the dangerous from the safety point of view.

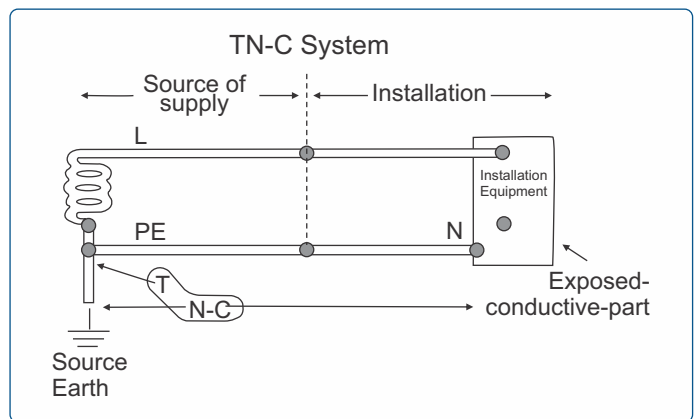

e. IT system

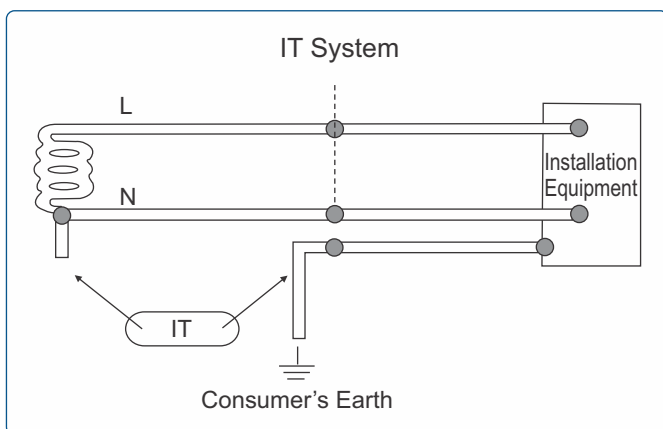

In an IT network, the distribution system has no connection to the earth at all, or it has only a high impedance connection. In such systems, an insulation monitoring device is used to monitor the impedance. Only the IT system guarantees risk-free continuity of supply in the presence of an insulation fault.

2.2 Comparison of Earthing systems

	TT	IT	TNS	TNC	TNC-S
Earth fault loop impedance	High	Highest	Low	Low	Low
RCD preferred?	Yes	No	Yes	No	After N and PE separate
Need earth electrode at site ?	Yes	Yes	No	No	No
PE conductor cost	Low	Low	Highest	Least	High
Risk of broken neutral	No	No	No	Highest	High
Safety	Safe	Less Safe	Safest	Less Safe	Safe
Electromagnetic interference	Least	Least	Low	High	Low
Safety risks	High loop impedance	Double fault, Overvoltage	Broken PE	Broken neutral	Broken neutral
Advantages	Safe and reliable	Continuity of operation, cost	Safest	Cost	Safety and cost

2.3 Choice of Earthing

Choice of earthing system for an installation depends on parameters:

1. Safety of person
2. Continuity of supply
3. Sensitivity of the equipment to the presence of harmonics in the system
4. Environment (risk of lightning strike)
5. Quality, maintenance and cost
6. Network size
7. Requirement of skilled operator and designer

3. Miniature Circuit Breaker (MCB)

An MCB is an automatically operated electrical switch designed to protect an electrical circuit from damage caused by overload and short circuit. Its basic function is to detect a fault condition and, by interrupting continuity, to immediately discontinue electrical flow. Unlike a fuse, which operates once and then has to be replaced, a circuit breaker can be reset (manually) to resume normal operation.

3.1 Selecting an MCB:

In order to achieve perfect overload protection, the normal current of the MCB (I_m) should not be less than the design current of the circuit (I_c) and that (I_m) should not exceed the current-carrying capacity of the conductors (I_w), and that the current causing effective operation of the protective device I_m does not exceed 1.45 times the current-carrying capacity of the conductor I_c , expressed as; $I_c < I_m < I_w$ e.g. If for a load of 800w, 220V; load current is 4A then wire capacity should be minimum 11A (i.e. 1 sq mm) and MCB rating should be 6A.

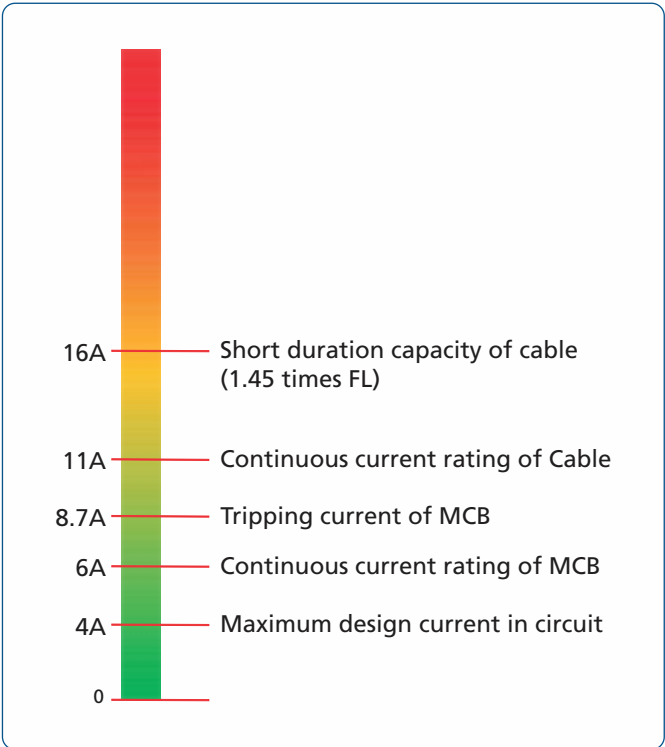

3.2 Application of different curves

Type	Setting	Application
B	3-5 In	Generator-sensitive loads very long circuit runs <i>Example: Incandescent lights, Heater, Geyser</i>
C	5-10 In	General, light and power <i>Example: Flourescent lights, Small motors, Fans, Refrigerators Window / Split ACs</i>
D	10-20 In	Motors & transformers sodium lighting highly inductive loads <i>Example: Water lifting pumps, UPS, Medium size motors</i>

3.3 Temperature de-rating chart

As per IS/IEC 60898, thermal calibration of an MCB is to be done at 30°C and if the manufacturer decides to do it at any other temperatures, the data has to be furnished on the breaker. When used at ambient temperatures exceeding the calibrated temperatures, MCBs tend to trip faster while carrying the rated current. This calls for de-rating the MCBs when used in ambiances, with temperatures higher than the design ambient temperature. At temperature higher than 30°C, the MCB require progressively less time to trip on the same level of overload.

Temperature Derating chart as per IEC 60898-1 (Calibration temperature : 30°C) :

Rating (A)	30°C	35°C	40°C	45°C	50°C	55°C	60°C	65°C	70°C
6	6.0	5.7	5.4	5.1	4.8	4.5	4.2	4.3	4.0
10	10.0	9.5	9.0	8.5	8.0	7.5	7.0	7.2	6.6
16	16.0	15.2	14.4	13.6	12.8	12.0	11.2	11.4	10.6
20	20.0	20.0	18.0	17.0	16.0	15.0	14.0	14.3	13.2
25	25.0	23.8	22.5	21.3	20.0	18.8	17.5	17.9	16.5
32	32.0	30.4	28.8	27.2	25.6	24.0	22.4	22.9	21.1
40	40.0	38.0	36.0	34.0	32.0	30.0	28.0	28.6	26.4
50	50.0	47.5	45.0	42.5	40.0	37.5	35.0	35.8	33.0
63	63.0	59.9	56.7	53.6	50.4	47.5	44.1	45.0	41.6

Temperature De-rating Chart as per IEC 60947-2 (Calibration Temperature: 50°C) :

In(A)	30°C	35°C	40°C	45°C	50°C	55°C	60°C	65°C	70°C
6	6.6	6.5	6.3	6.2	6	5.7	5.4	5.1	4.8
10	11	10.8	10.5	10.3	10	9.5	9	8.5	8
16	17.6	17.2	16.8	16.4	16	15.2	14.4	13.6	12.8
20	22	22	21	20.5	20	19	18	17	16
25	27.5	26.9	26.3	25.6	25	23.8	22.5	21.25	20
32	35.2	34.4	33.6	32.8	32	30.4	28.8	27.2	25.6
40	44	43	42	41	40	38	36	34	32
50	55	53.8	52.5	51.3	50	47.5	45	42.5	40
63	69.3	67.7	66.2	64.6	63	59.9	56.7	53.55	50.4

3.4 Current-limiting and Energy-limiting class

Current limitation is the technique used in circuit breakers to limit the short circuit current to reach its prospective value.

Current limitation can be achieved by following methods:

1. By Limiting the Fault

- By series resistors: using a series resistor to limit current on short circuit, but this wastes a lot of energy in limiting resistors.
- By series inductors coil – lot of heat loss combined with bulky size of inductor coils.

2. By Current Limiting Technology

- A current limiting circuit breaker cuts off the fault current much before it attains its peak value and hence greatly reduces the thermodynamic stresses on an electrical network.
- On a 50 Hz electrical network, fault current takes 5 msec to reach its prospective peak value.

A current limiting circuit breaker interrupts the fault current within 5 msec and clears the fault within 10 msec to limit the fault current and minimize let thru energy for maximum protection of electrical network.

Let thru energy is the amount of fault energy which passes through a circuit breaker to downstream network measured from the instant fault occurs in a system to the instant the circuit breaker clears the fault.

IEC classify MCBs into three classes depending upon their "Quality of current limiting" and let thru energy of a circuit breaker on short circuit class.

Class 1	No Limitation
Class 2	370 kA ² S
Class 3	110 kA ² S

As per EN-60898-1 -2003, for 10kA C-curve MCB (Greater than 16A up to and including 32A)

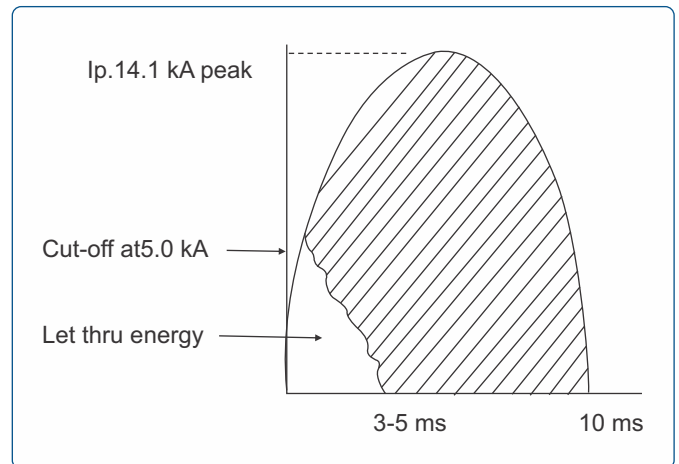

3.5 Some Important Definitions and Symbols (National and International Standards)

U_e = rated service voltage

U_i = rated insulation voltage ($>U_{e\max}$)

U_{imp} = rated impulse withstand

I_{cm} = rated short circuit making capacity

I_{cn} = rated short circuit capacity

I_{cs} = rated service short circuit breaking capacity

$I_{\Delta n}$ = rated residual operating current (often called residual sensitivity)

I_n = rated current = maximum value of current used for the temperature rise test

Δt = trip delay of residual current devices

Fault Current	Trip time
$1.13 I_n$	Greater than 1 hour
$1.45 I_n$	Less than 1 hour
$2.55 I_n$	1 to 120 seconds

The inverse time delay characteristics of all MCBs complying with IEC 60898 must operate within these limits.

The difference between three types of characteristic curve B, C and D concerns only the magnetic instantaneous trip which provides short circuit protection.

Curve type	Breaker trip limits
Type B	3 to 5 times I_n
Type C	5 to 10 times I_n
Type D	10 to 20 times I_n

3.6 Suitability for Isolation as per IEC 60947-2 :

As per IEC 60947-2, certain conditions, as mentioned below, needs to be satisfied by the product so that manufacturer can claim it to be suitable for isolation.

- An isolation distance to be maintained in open position such that it satisfy the impulse withstand voltage and leakage current tests as per the standard.
- Indication of the position of the main contacts shall be provided by one or more of the following means:
 - a. the position of the actuator;
 - b. a separate mechanical indicator;
 - c. visibility of all the moving main contacts
- Products which complies above condition can be marked as suitable for isolation symbol on the product : 

3.7 MCB Characteristic Curves

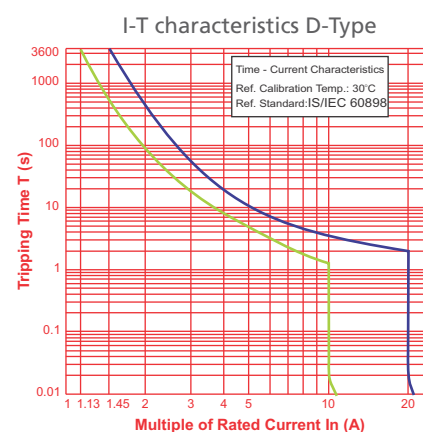
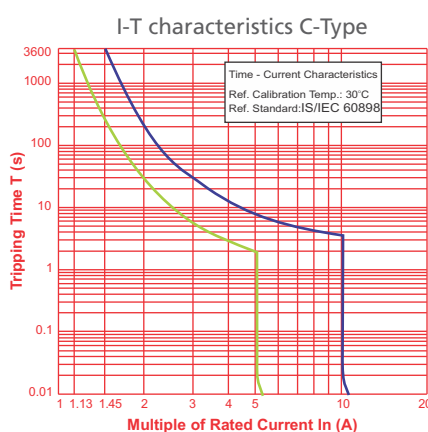
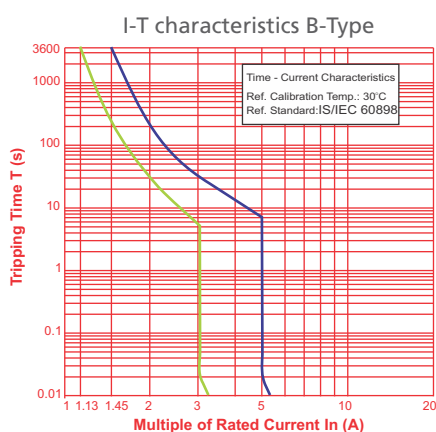

3.8 Watt loss table

Current (A) I_n	6	10	16	20	25	32	40	50	63
Loss (Watt)	1.36	1.8	1.8	2.49	3.52	3.4	3.75	5.17	5.93

4 RCCB

4.1 Danger of Human – Electrocution

Current I v/s Flow Time

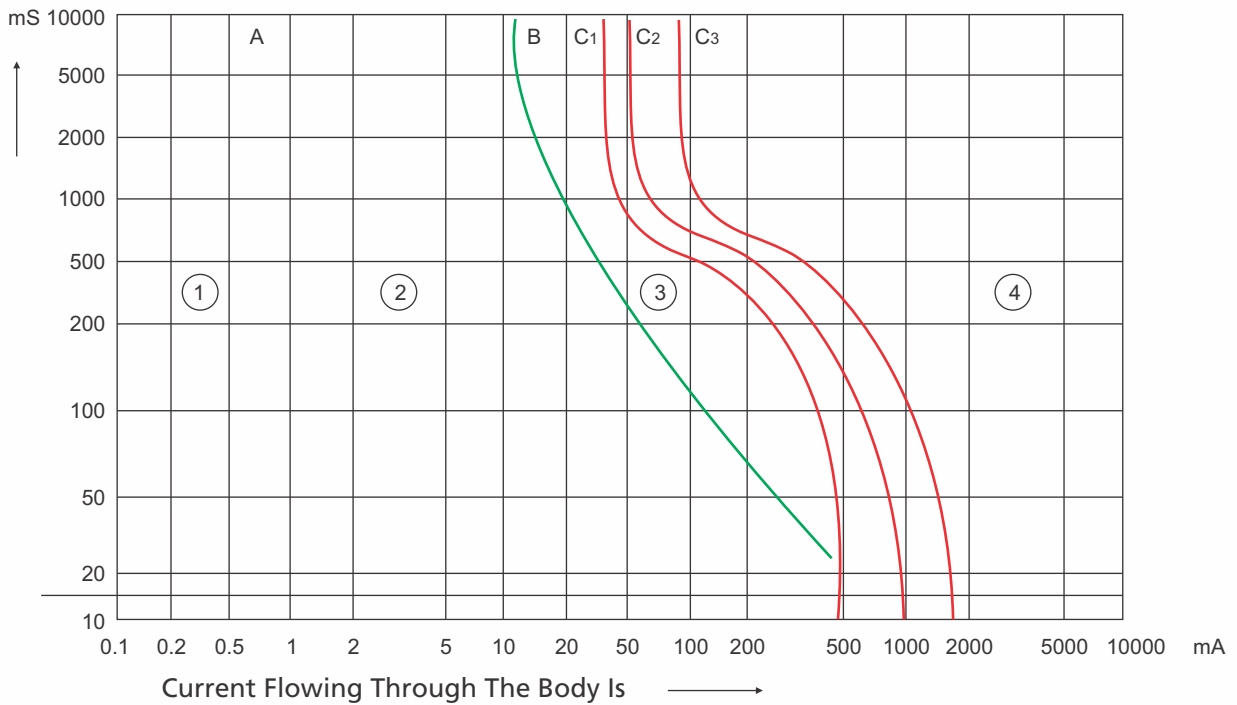

① Unperceived

③ Reversible effects : muscular contraction

② Perceived

④ Possible irreversible effects

C1= 5% risk C3>50% risk

Duration of current flow in the body as a function of current strength: In this graph, the effect of AC current (15 to 100 Hz) has been divide into four zones (as per IEC60479-1).

The gravity of an electric shock depends on the following factors:

- Current value
- Time it remains in the human body
- Path it takes through the human body
- Impedance of the human body
- When a current in excess of 30 mA flows through part of the human body, the person is in danger if this current is not interrupted in a relatively short time.

Importance of RCCB

The fault current overloads and short circuits can be detected by circuit breakers like MCBs, MCCBs, HRC Fuses, etc. But circuit breakers do not detect leakage currents which are dangerous for humans and livestock. If not detected, these leakages can lead to fire hazards. We need a solution that detects such leakage currents and disconnects the circuits from the power supply. Here comes the solution in the form of RCCB (Residual Current Circuit Breaker) also known as ELCB (Earth Leakage Circuit Breaker) which provides protection against direct and indirect contact of personnel or livestock and against fires.

Critical Current Thresholds

According to the medical study, effect of various current levels on human bodies is as shown below.

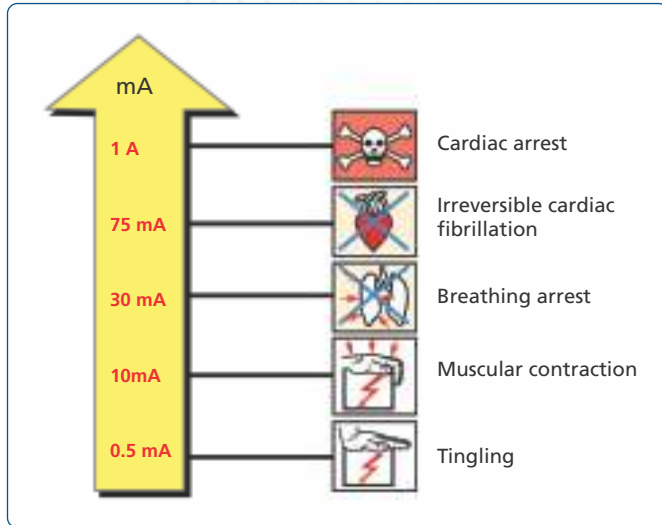

4.2 Working Principle of RCCB

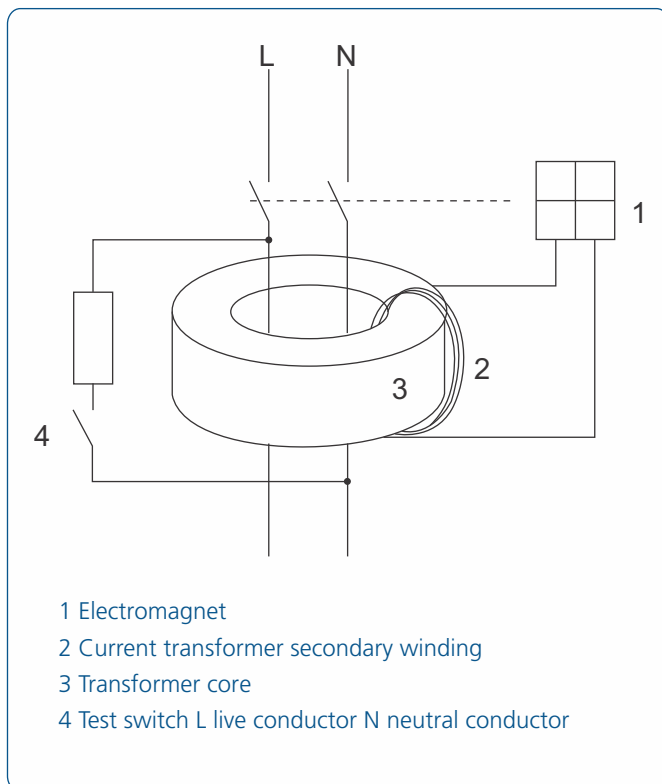

RCCBs operate by measuring the current balance between two conductors using a differential current transformer. This measures the difference between the current flowing out of the live conductor and that returning through the neutral

conductor. If these do not sum to zero, there is a leakage of current to somewhere else (to earth/ground, or to another circuit), and the device will open its contacts.

RCCBs have different current sensitivities which can be used for various applications.

Sensitivities	Application
30mA	For protection against direct contacts
100mA	For protection against indirect contact (where generally leakage is high)
300mA	For protection against industrial installations, fire, etc.

To ensure safety, the RCCB switches turn off the protected circuit immediately. If there is an insulation fault causing a short-circuit to an exposed part (frame etc.) of machinery and equipment (protection against indirect contact), the maximum permissible touch voltage U must occur at a residual current greater than or equal to the rated residual operating current I that triggers the I_n RCCB. This condition is met by earthing the exposed part with a sufficiently low resistance to earth R_E .

$$\text{Earth Resistance (RE)} < \frac{\text{Touch Voltage (U)}}{\text{Rated Residual Operating Current (I)}}$$

4.3 Precaution for Installations

- Wiring should be done as per the wiring diagram. by a trained and qualified electrician.
- All wiring necessary for operation shall be passed through the RCCB.
- The neutral conductor must be insulated against earth to the same extent as the live conductors.
- All equipment used must be properly earthed.
- To ensure correct functioning, care must be taken that the neutral conductor on the load side of the RCCB must not be connected to earth, otherwise nuisance tripping may occur or tripping may be impaired.
- Suitable device either MCB or HRC fuses shall be used for short circuit and overload protection of the circuit under installation.

4.4 Fault finding when RCCB trips

Switch OFF all the switches/MCB connected in the circuit downstream the RCCB. Switch ON RCCB and switch ON the Switches one by one. You will find that during switching ON of a particular appliance/switch RCCB trips again and again which shows that this is the faulty circuit/appliance. Isolate the faulty circuit, rectify the fault and switch ON the RCCB.

Faults existing downstream of the RCD

- **Indirect contact.** An RCD may be used to provide protection against electric shock due to indirect contact in an installation.
- **Direct contact.** An RCD may be used to provide supplementary protection against direct contact.
- **Incorrect application.** An RCD must be correctly selected and erected for the particular application. For example, protecting an entire installation using a single high sensitivity RCD can, in many cases, lead to unwanted tripping, particularly in industrial environments where inductive loads will cause greater transient overvoltages and where longer cable runs will result in larger values of capacitance to earth.
- **No discrimination between series connected RCDs.** A fault downstream of two series-connected RCDs may result in operation of either device. A fault downstream of the second device will be 'seen' by both devices. Inconvenience may result if the upstream device operates. Discrimination, where required, must be ensured by means such as selecting a time delayed device for the upstream device.
- **Loose connections.** A loose connection downstream of an RCD may cause it to operate due to transient voltages or capacitive effects. Every connection must be properly constructed of durable electrical continuity and adequate mechanical strength correctly selected enclosed and accessible, where required.
- **Crossed neutral on split load distribution board or consumer unit.**

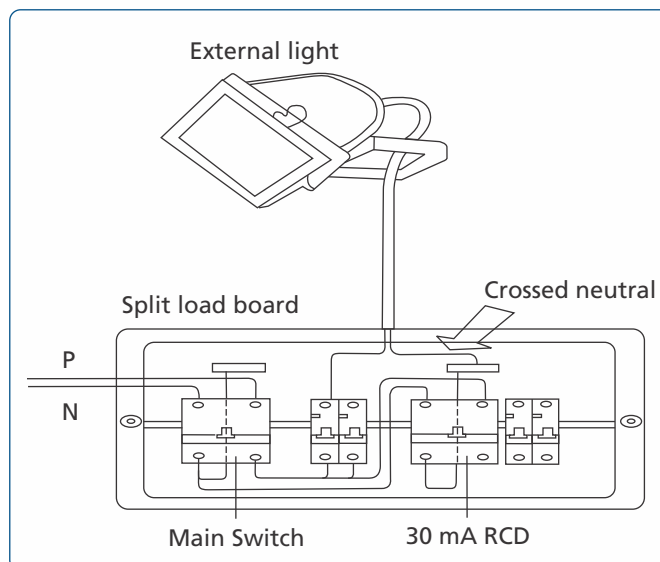

In the above diagram, the external lighting circuit has been incorrectly connected. The MCB supplying the circuit is connected to the non-RCD-protected side of the split load board but the neutral conductor for the circuit has been inadvertently connected downstream of the RCD.

As soon as the outside light is energized, the RCD will see a large imbalance and will operate. The neutral must be taken from the same final circuit, never from another circuit, as has happened in this example. Circuits must be kept separate; in this example a 'borrowed neutral' situation exists presenting a potential shock risk for an electrician attempting to troubleshoot the problem.

- **Neutral-to-Earth fault.** A neutral-to earth fault or in advertent connection of neutral to earth downstream of an RCD will probably result in the device operating as part of the neutral current will flow in the circuit protective conductor resulting in the RCD seeing an imbalance (refer fig below). A neutral-to-earth fault can be caused by:
 - A neutral conductor touching an earthed mounting box or earthed metal conduit
 - Reversed neutral and earth connections at an accessory or item of current-using equipment
 - Withdrawal of a fuse or switching off a circuit-breaker in a final circuit resulting in an RCD tripping as the neutral is normally not interrupted.
 - Nails and picture hooks, screws and power drills: A floorboard nail driven between the neutral and earth conductors creates a neutral to earth fault which is likely to cause an upstream RCD to trip. The fault can be located by insulation testing. The damaged cable must be replaced and either relocated to avoid further damage or protected.

- Mineral insulated cables. Mineral insulated cables can absorb moisture if not correctly terminated resulting in reduced insulation which may cause an RCD to trip as a certain amount of outgoing phase current will return through the MI cable sheath causing the RCD to detect an imbalance. Insulation testing should identify the problem.
- Moisture ingress can cause reduced insulation resulting in RCD operation. Reduced insulation can result from wet plaster, condensation or water entry into accessories. Similarly, some appliances may exhibit reduced insulation causing RCD operation. Certain installed services, such as heating elements in cookers can have reduced insulation when cold; the insulation increasing when hot. The manufacturer's instructions should be consulted.
- Double-pole switching. Double pole switching within the fixed wiring is known to trip an RCD when switching off or on due to capacitive effects. Changing over from double pole to single pole switching can overcome the problem, where such replacement is permissible and safe.

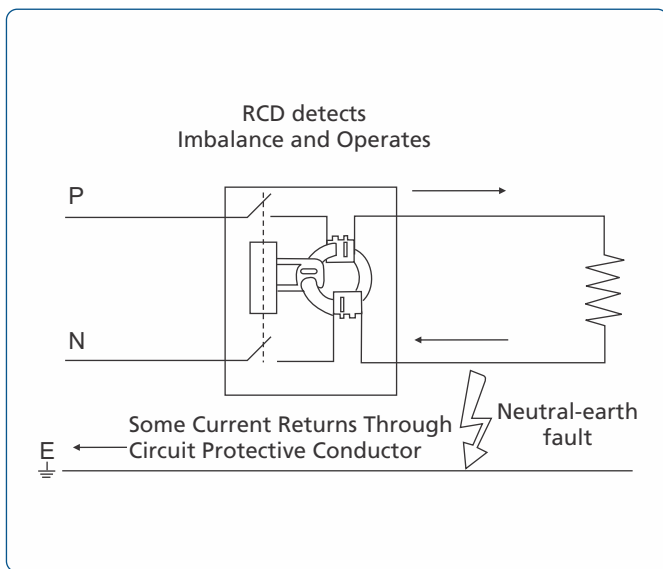

Faults Upstream of the RCD

A loose connection upstream of the RCD such as at the main switch or at the busbar connections can cause the device to operate.

Mains-borne disturbances such as spikes, voltage surges and dips, a lightning strike and the operation of distribution network switchgear and protective devices combined with capacitance to earth within the installation can cause unwanted RCD operation. A filter may be of assistance.

Site machinery or plant and installed services can cause

mains borne interference. Motors such as lift motors, control gear for discharge lighting and transformer inrush currents can cause unwanted RCD operation. Although significant transients can arise within an installation they would normally only occur under fault conditions. They might, however, travel to other installations where they could cause unwanted tripping of a RCD.

Overhead lines: Unwanted tripping may occur more frequently in an installation supplied by overhead lines compared to one supplied by an underground concentric cable. An underground concentric cable is, by its very nature, a good attenuator of transient overvoltages. Spurious tripping may be avoided by installing a filter upstream of the RCD at the origin of the installation.

4.5 RCCBs : Domestic Installation

RCCBs can be installed mainly in two ways:

1. Whole house protection: In this type of protection the RCCBs serve as the main switch. This type of protection is very popular but has a major disadvantage that all the circuits are disconnected in the event of a fault.

2. Selective protection: This type of protection can be divided into two types.

A. Split busbar consumer unit: In this case all circuits are fed through an overall isolator and selected circuits additionally through RCCBs. The examples of selected circuits are socket outlets, garage circuits, etc. So this reduces the inconvenience in the event of fault.

B. Per Phase Isolation (PPI): A RCCB is used as sub-incomer for each individual phase. In case of a fault, only faulty phase will be disconnected and remaining phases will not be affected.

RCCB should be protected against overload and short-circuit by using backup MCB or Fuse as per table below:

RCCB Rating (A)	L&T MCB (A)	gG L&T Fuse (A)
25	25	25
40	40	40
63	63	63
100	100	100

Add an Appeal to your Wall with New Range of Distribution Boards



Clarity/12/2014/RP



Outside, it's a work of art. The aesthetic lines of the E&A distribution board give your home a touch of class. Subtle, yet elegant, it is a style statement.

Inside, it's state-of-the-art. E&A's distribution board is designed for total safety. It is easy to install, operate and maintain. What's more, E&A's wide range ensures that there's one for your application.

Contact your nearest authorised E&A stockist today.

Customer Interaction Center (CIC)

BSNL / MTNL (toll free): 1800 233 5858 Reliance (toll free): 1800 200 5858

Tel: 022 6774 5858 Fax: 022 6774 5859 Email: cic@Lntebg.com Web: www.Lntebg.com

Electrical Standard Products (ESP) Offices:

HEAD OFFICE

L&T Electrical & Automation
L&T Business Park,
Tower 'B' / 3rd Floor
Saki Vihar Road, Powai
Mumbai 400 072
Tel: 022-67053229
Fax: 022-67051112
e-mail: cic@LNTEBG.com

BRANCH OFFICES

L&T Electrical & Automation
501, Sakar Complex I
Opp. Gandhigram Rly. Station
Ashram Road
Ahmedabad 380 009
Tel: 079-66304006-11
Fax: 079-66304025
e-mail: esp-ahm@LNTEBG.com

L&T Electrical & Automation
M/s Larsen & Toubro Ltd
No 38, Cubbon Road
Bengaluru 560 001
Tel: 080-46136103 / 100
e-mail: esp-blr@LNTEBG.com

L&T Electrical & Automation
131/1, Zone II, Maharana Pratap Nagar
Bhopal 462 011
Tel: 0755-3080511 / 05 / 08 / 13 / 17 / 19
Fax: 0755-3080502
e-mail: esp-bho@LNTEBG.com

L&T Electrical & Automation
Plot No. 559, Annapurna Complex
Lewis Road
Bhubaneswar 751 014
Tel: 0674-6451342 / 2436690 / 2436696
Fax: 0674-2537309
e-mail: esp-bsr@LNTEBG.com

L&T Electrical & Automation
Aspire Towers, 4th Floor
Plot No. 55, Phase-I
Industrial & Business Park
Chandigarh-160 002
Tel: 0172-4646840 / 41 / 42 / 46 / 53
Fax: 0172-4646802
Email: esp-chd@LNTEBG.com

L&T Electrical & Automation
L&T Construction Campus
TC-1 Building, II Floor
Mount-Poonamallee Road
Manapakkam
Chennai 600 089
Tel: 044-2270 6800
Fax: 044-2270 6940
e-mail: esp-maa1@LNTEBG.com

L&T Electrical & Automation
67, Appuswamy Road, Post Bag 7156
Opp. Nirmala College
Coimbatore 641 045
Tel: 0422-4588120 / 1 / 5
Fax: 0422-2588148
e-mail: esp-cbe@LNTEBG.com

L&T Electrical & Automation
1&2, Vijay Park, Main Chakrata road
Opp: Anandam, Ballupur Chowk
Dehradun 248001
Tel: 9582252411

L&T Electrical & Automation
Khairasol, Degaul Avenue
Durgapur 713 212
Tel: 0343-2540448 / 2540449 / 2540443
Fax: 0343-2540442
e-mail: esp-dgp@LNTEBG.com

L&T Electrical & Automation
5, Milanpur Road, Bamuni Maidan
Guwahati 781 021
Tel: +91 8876554417
e-mail: esp-ghy@LNTEBG.com

L&T Electrical & Automation
II Floor, Vasantha Chambers
5-10-173, Fateh Maidan Road
Hyderabad 500 004
Tel: 040-67015052
Fax: 040-23296468
e-mail: esp-hyd@LNTEBG.com

L&T Electrical & Automation
Monarch Building, 1st Floor
D-236 & 237, Amrapali Marg
VaiShali Nagar
Jaipur 302 021
Tel: 0141-4385914 to 18
Fax: 0141-4385925
e-mail: esp-jai@LNTEBG.com

L&T Electrical & Automation
Akashdeep Plaza, 2nd Floor
P. O. Golmuri
Jamshedpur 831 003
Jharkhand
Tel: 0657-2312205 / 38
Fax: 0657-2341250
e-mail: esp-jam@LNTEBG.com

L&T Electrical & Automation
Skybright Bldg; M. G. Road
Ravipuram Junction, Ernakulam
Kochi 682 016
Tel: 0484-4409420 / 4 / 5 / 7
Fax: 0484-4409426
e-mail: esp-cok@LNTEBG.com

L&T Electrical & Automation
3-B, Shakespeare Sarani
Kolkata 700 071
Tel: 033-42005982
Fax: 033-22821025 / 7587
e-mail: esp-ccu@LNTEBG.com

L&T Electrical & Automation
A28, Indira Nagar, Faizabad Road
Lucknow 226 016
Tel: 0522-4929905 / 04
Fax: 0522-2311671
e-mail: esp-lko@LNTEBG.com

L&T Electrical & Automation
No: 73, Karpaga Nagar, 8th Street
K. Pudur
Madurai 625007
Tel: 0452-2567405 / 2561068 / 2561657
Fax: 0452-2567552
e-mail: esp-mdu@LNTEBG.com

L&T Electrical & Automation
L&T Business Park, Tower 'B' / 3rd Floor
Saki Vihar Road, Powai
Mumbai 400 072
Tel: 022-67052874 / 2737 / 1156
Fax: 022-67051112
e-mail: esp-bom@LNTEBG.com

L&T Electrical & Automation
Unnati Building, 2nd Floor
Automation Campus
A-600, TTC Industrial area
Shil-Mahape road, Mahape
Navi Mumbai - 400710

L&T Electrical & Automation
12, Shivaji Nagar
North Ambajhari Road
Nagpur 440 010
Tel: 0712-2260012 / 6606421
Fax: 2260030 / 6606434
e-mail: esp-nag@LNTEBG.com

L&T Electrical & Automation
32, Shivaji Marg
P. O. Box 6223
New Delhi 110 015
Tel: 011-41419514 / 5 / 6
Fax: 011-41419600
e-mail: esp-del@LNTEBG.com

L&T Electrical & Automation
Grand Chandra, 2nd Floor
Fraser Road
Opposite Doordarshan Kendra
Patna 800001
Tel: 8102440613
e-mail: esp-patna@LNTEBG.com

L&T Electrical & Automation
L&T House
P. O. Box 119
191/1, Dhole Patil Road
Pune 411 001
Tel: 020-48544395 / 48544279
e-mail: esp-pnq@LNTEBG.com

L&T Electrical & Automation
Crystal Tower,
4th Floor, G. E. Road
Telibandha
Raipur - 492 006
Tel: 0771-4283214
e-mail: esp-raipur@LNTEBG.com

L&T Electrical & Automation
3rd Floor
Vishwakarma Chambers
Majura Gate, Ring Road
Surat 395 002
Tel: 0261-2473726
Fax: 0261-2477078
e-mail: esp-sur@LNTEBG.com

L&T Electrical & Automation
Radhadaya Complex
Old Padra Road
Near Charotar Society
Vadodara 390 007
Tel: 0265-6613610 / 1 / 2
Fax: 0265-2336184
e-mail: esp-bar@LNTEBG.com

L&T Electrical & Automation
Door No. 49-38-14/3/2, 1st floor,
NGGO's Colony, Akkayyapalem,
Visakhapatnam - 530 016
Tel: 0891-2791126 / 2711125
Fax: 0891-2791100
e-mail: esp-viz@LNTEBG.com

Product improvement is a continuous process. For the latest information and special applications, please contact any of our offices listed here. Product photographs shown for representative purpose only.



L&T Electrical & Automation, Electrical Standard Products

L&T Business Park, TC-2, Tower B, 3rd Floor, Gate No. 5, Saki Vihar Road, Powai,
Mumbai - 400 072, INDIA www.Lntebg.com

Customer Interaction Center (CIC)

BSNL / MTNL (toll-free): 1800 233 5858 Reliance (toll-free): 1800 200 5858
Tel: 022 6774 5858 Email: cic@Lntebg.com Web: www.Lntebg.com