

POWER QUALITY SOLUTIONS

ABOUT US



Switchgear Factory, Navi Mumbai



Switchgear Factory, Ahmednagar



Switchgear Factory, Vadodara

L&T Electrical & Automation (E&A) is a market leader for electrical distribution, monitoring and control solutions in the low voltage category.

Popular among customers as L&T Switchgear, E&A offers a wide range of low and medium voltage switchgear, motor starters, electrical systems, industrial automation, building electrical solutions, energy management solutions, electrical modernization solutions and metering solutions. Its products and solutions cater to key sectors of economy like industries, utilities, infrastructure, building and agriculture.

E&A's manufacturing operations at Navi Mumbai, Ahmednagar, Vadodara, Coimbatore and Mysuru in India adhere to global practices of excellence and receive support from well-equipped in-house design and development centres as well as tooling facilities that contribute to precision in manufacturing.

Products of Power Quality	1
Power Factor Correction	4
♦ Benefits of Using LT Capacitors over HT Capacitors	5
♦ Capacitor Technology	7
♦ Life of Power Capacitors	9
♦ Capacitor Power Loss Calculation	10
♦ Discharge Resistors	11
♦ Voltage Selection of Power Capacitors	12
♦ Standard Duty Capacitors	13
♦ Standard Duty Box Capacitors with MCB & LED	16
♦ Heavy Duty Capacitors	18
♦ Gas Filled Capacitors	21
♦ Super Heavy Duty Capacitors	23
♦ LT APP Capacitors	25
♦ LTXL: Ultra Heavy Duty Cylindrical Capacitors	27
♦ LTXL: Ultra Heavy Duty Box Capacitors	29
Harmonics	33
♦ Harmonic Amplification	34
♦ Harmonic Resonance	35
♦ Interpretation of Total Harmonic Distortion (THD)	37
♦ Understanding Current & Voltage Harmonics	38
♦ Triplen Harmonic Mitigation	42
♦ Harmonic Mitigation	44
♦ Detuned Filters	45
♦ Importance of Using The Right Detuned Reactor	48
♦ Linearity of Reactor	50
♦ Q-factor	51
♦ Reactors - Harmonic Filters	53
♦ Basics of Active Harmonic Filters	56
♦ Active Harmonic Filters	60
♦ Harmonics and its Impacts on Power Factor	65
♦ Impact of Harmonics on DG Sets	67
Capacitor Switching in APFC Panel	71
♦ Comparative Study of Switching Methods	72
♦ Capacitor Duty Contactors – Type MO C	77
♦ Dynamic Power Factor Correction	84
♦ Thyristor Switching Modules	88
Automatic Power Factor Controller	
♦ etaULTRA	92
♦ etaSMART	97
♦ etaCON - M	103
Selection of Capacitor	111
♦ Motor Power Factor Compensation	115
♦ Transformer Compensation	117
♦ Reactive Power Compensation of DG Sets	118
etaSYS - Standard APFC Panels	120
♦ Capacitor Step Size Selection Guidelines in APFC Panels	127
♦ Fuse Selection for APFC Panels	130
♦ MCCB Selection for APFC Panels	131
♦ Cable Selection for Capacitors	132
♦ Thermal Design of APFC Panels	133
etaPRO V3.0 - Multi-utility Software Package	137

POWER CAPACITORS

Cylindrical Type

Box Type



Standard Duty 1-33.1 kVAr Heavy Duty 1 to 33.1 kVAr Gas Filled 1-30 kVAr



Standard Duty 1-33.1 kVAr Standard Duty (MCB + LED) 7.5 - 25 kVAr Heavy Duty 1-50 kVAr



Super Heavy Duty 1.2-33.3 kVAr LTXL: Ultra Heavy Duty 5-25 kVAr



APP Capacitors 5-50 kVAr LTXL: Ultra Heavy Duty 5-50 kVAr

HARMONIC FILTERING



Detuned Harmonic Filter
1-100 kVAr
Copper and Aluminium
7% and 14%



Active Harmonic Filter
30-800A
3Ph 3 Wire/4 Wire

CAPACITOR SWITCHING



Thyristor Switching Modules
10, 25 & 50 kVAr



Capacitor Duty Contactors -
Type MO C
3-100 kVAr

POWER FACTOR CONTROLLER



etaULTRA Series
APFC Controller
Upto 16 Steps for Contactor Switching
Upto 14 Steps for Thyristor Switching



etaSMART Series
APFC Controller
Upto 16 steps



etaCON M Series
APFC Controller
Upto 14 steps

Hybrid APFC Controller
Upto 8 Steps for Contactor Switching
& 8 Steps for Thyristor Switching

**REACTIVE
POWER
MANAGEMENT
SOLUTIONS**



etaSYS APFC Panels
35-500 kVAr



Principles of Power Factor Correction

A vast majority of electrical loads in low voltage industrial installations are inductive in nature. Typical examples are motors and transformers, which consume both active and reactive power. The active power is used by the load to meet its actual work requirements whereas reactive power is used by the load to meet its magnetic field requirements. The reactive power (inductive) is always 90° lagging with respect to active power as shown in figure 1. Figure 2 & 3 show the flow of kW, kVAr and kVA in a network.

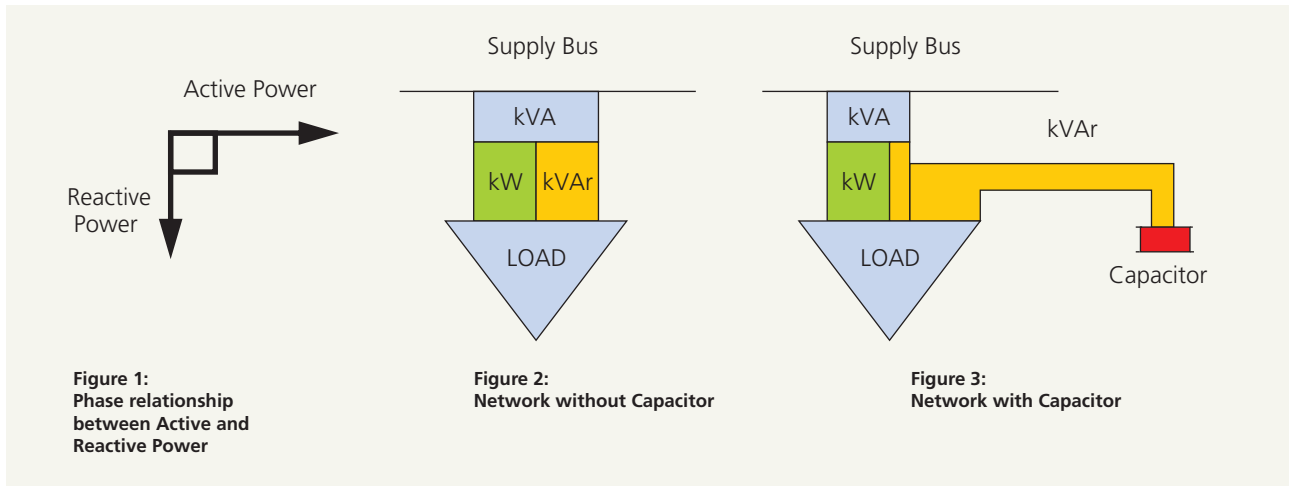

Flow of active and reactive power always takes place in electrical installations. This means that the supply system has to be capable of supplying both active and reactive power. The supply of reactive power from the system results in reduced efficiency of the installation due to:

- Increased current flow for a given load
- Higher voltage drops in the system
- Increase in losses of transformers, switchgear and cables
- Higher kVA demand from supply system as given in figure 2
- Higher electricity cost due to levy of penalties / loss of incentives

It is therefore necessary to reduce & manage the flow of reactive power to achieve higher efficiency of the electrical system and reduction in cost of electricity consumed.

The most cost effective method of reducing and managing reactive power is power factor improvement through Power Capacitors. The concept of reduction in kVA demand from the system is shown in figure 3.

Benefits of Power Factor Correction

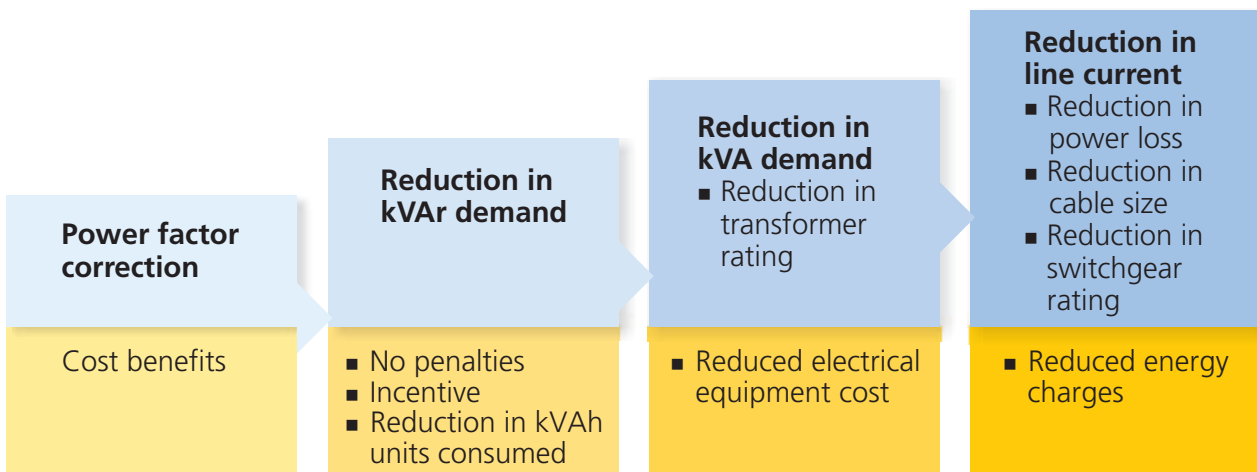

Power factor compensation can be provided on either LT or HT side of the distribution transformer for the loads at LT side. Often compensation is done on the HT side as the electricity board measures power factor on HT side for penalty calculation. Also, HT capacitors involve low initial investment as compared to LT capacitors. However, compensation achieved by HT capacitors does not provide the benefits offered by the use of LT capacitors, as discussed in this section.

Consider two cases with compensation provided on HT and LT side respectively as shown in figure 1 and 2.

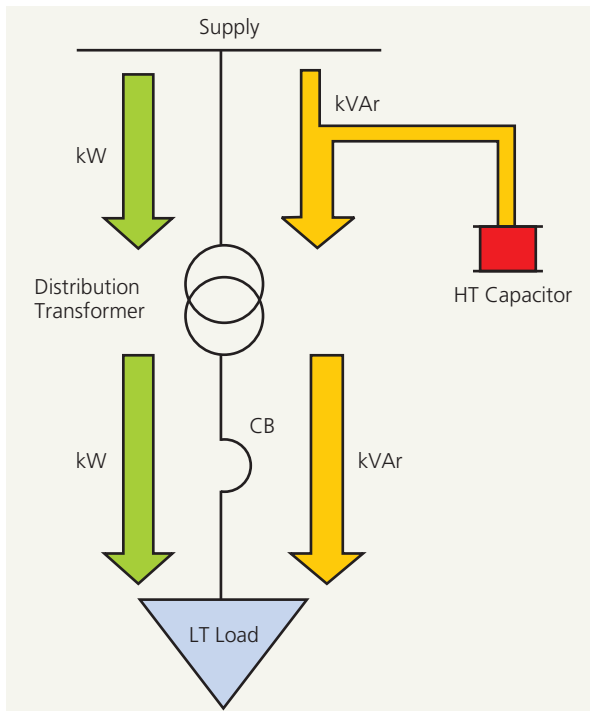

Fig 1: Compensation on HT Side

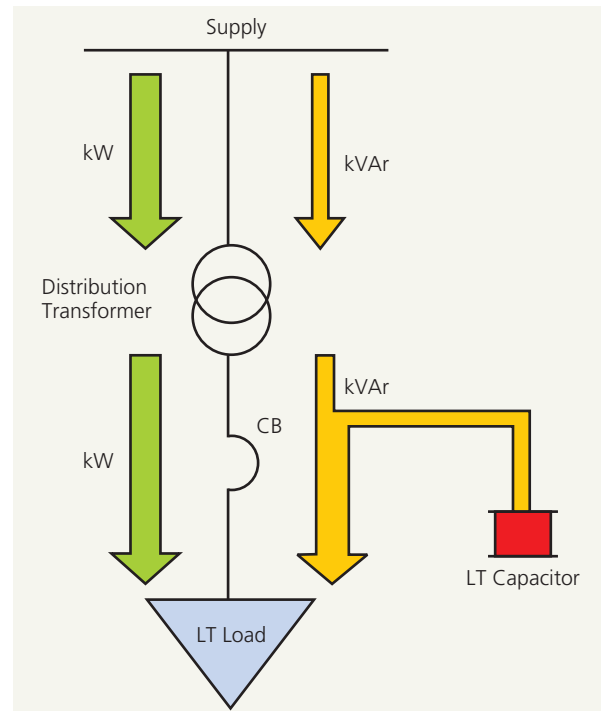

Fig 2: Compensation on LT Side

As seen in fig 1, with the capacitor connected on the HT side, the compensated reactive power flow through the transformer does not reduce and hence there is no change in current flow. Although the HT side power factor is improved, the LT side power factor remains same. However, as seen in fig 2, connecting capacitor on LT side reduces the reactive power flow through the transformer and we get improved power factor and reduced current flow on both LT and HT sides.

1. Reduction in Transformer Copper Losses

Consider a load of 1200 kW connected to a transformer of 2000 kVA. The typical full-load copper losses in a 2000 kVA transformer are 25000 W.

When compensation is provided on HT side, operating power factor of the transformer is 0.75 (same as uncompensated), denoted by $\cos\phi_1$.

When compensation is provided on LT side, operating power factor of the transformer is 0.98 (compensated), denoted by $\cos\phi_2$.

$$\text{Power Saving} = W_f * K * \left(\frac{1}{\cos\theta_1} - \frac{1}{\cos\theta_2} \right)$$

Where,

$$W_f = \text{Full Load Copper Losses} = 25000 \text{ W}$$

$$K = \frac{\text{Load in kW}}{\text{kVA rating of transformer}} = 0.6$$

Power Saving (in W)	=	25000*0.6*(1/.75-1/.98)	=	4694 W
Monthly Energy Savings (in kWh)	=	4694 *24*30/1000	=	3380 kWh
Typical Energy Charge (in Rs/kWh)	=	Rs. 6 per kWh		
Monthly Cost Saving (in Rs)	=	6*3380	=	Rs. 20278/-
Yearly Cost Savings (in Rs)	=	20278*12	=	Rs. 243330/-

Thus, LT compensation provides monthly savings of Rs. 20,278/- for a 2000 kVA transformer. Additionally, the operating temperature of the transformer is relatively less because of reduced copper losses. Hence, apart from monetary benefits, LT compensation also ensures longer life of the transformer.

2. Capacity Release in Transformer

Consider a 2000 kVA transformer connected to a load.

Cast 1: When compensation is provided on HT side, operating PF of transformer = 0.75

Maximum load that can be connected = 2000*0.75 = 1500 kW

Cast 2: When compensation is provided on LT side, operating PF of transformer = 0.98

Maximum Load that can be connected = 2000*0.98 = 1960 kW

Additional load that can be connected under the same transformer = 460 kW

LT compensation allows release of capacity of 460 kW with the same transformer. Thus, additional load can be easily connected to the system without any additional investments in new transformers.

3. Optimized Main Incomer Switchgear Rating

LT side capacitor, when connected after the main incomer reduces the current drawn by the same set of loads. Hence incomer switchgear rating can be optimized and the investment cost of the main incomer can be reduced.

Apart from those mentioned above, LT compensation also offers other advantages, such as

- Maintenance of LT capacitors and panels is easier and does not require complex safety measures
- Spares and accessories for the same are easily available and relatively cheaper

Optimum solution: Sense the PF from HT side and Capacitor switching on LT side near the load since electricity board meters are connected on HT side.

MPP (Metalized Poly-propylene)

Capacitors are used in diverse applications, and hence different capacitor technologies are available. In low voltage applications, LT cylindrical capacitors which are made in accordance with metalized polypropylene technology, have proved to be the most appropriate and the most cost effective amongst all technologies. Depending on the nominal voltage of the capacitor, the thickness of the polypropylene film differs. **Metallization is done on one side of the poly-propylene film.**

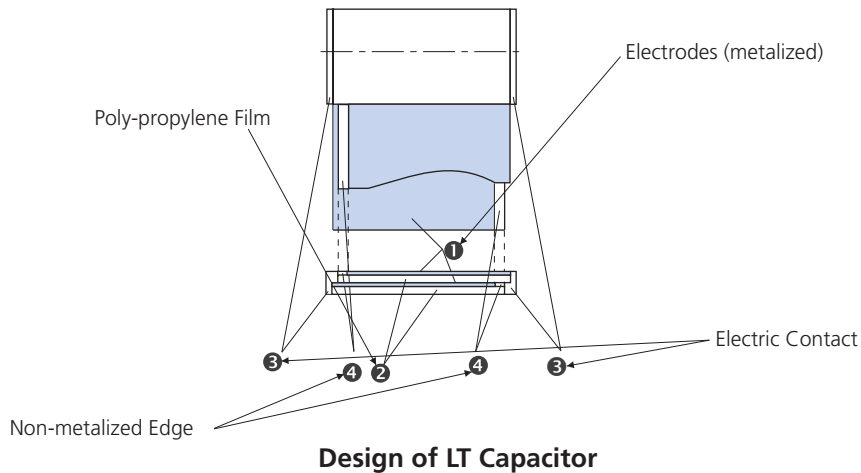

Design of LT Capacitor

Self - Healing

At the end of service life, or due to inadmissible electrical or thermal overload, an insulation breakdown may occur. This breakdown causes a small arc which evaporates the metal layer around the point of breakdown and hence re-establishes the insulation at the place of perforation. After electric breakdown, the capacitor can still be used. The decrease of capacitance caused by a self-healing process is less than 100 pF. The self-healing process lasts for a few microseconds only and the energy necessary for healing can be measured only by means of sensitive instruments.

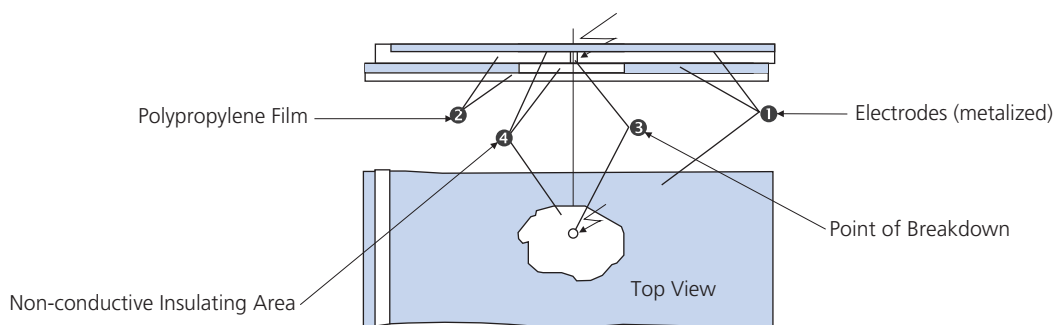

Self - Healing Breakdown

Impregnation

Our LT-type capacitors are impregnated to safeguard from environmental influences and to guarantee reliable, long-term operation. Vacuum impregnation eliminates air and moisture, improves "self-healing" and reduces thermal resistance.

Over Pressure Disconnecter (OPD)

At the end of service life or after several self-healing operations or due to inadmissible electrical or thermal overload, over pressure builds up and causes an expansion of the cover. Expansion over a certain limit causes the tear-off of the internal fuses. The active capacitor elements are thus cut-off from the source of supply. The pressure within the casing separates the breaking point so rapidly that no harmful arc occurs.

Operating Condition

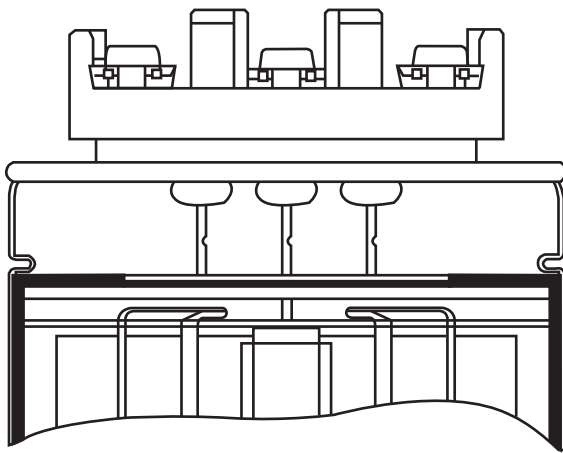

Torn - off Condition

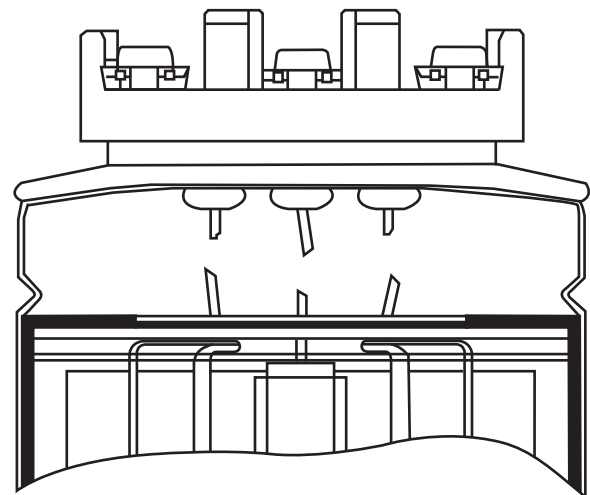

Construction Details

Cylindrical capacitors consist of three units of single phase capacitors connected in delta kept inside an aluminium can. Technologically similar to cylindrical capacitors, box type capacitors consist of three or six single phase cylindrical capacitor cells. The individual cells are wired together and mounted on a steel frame. The steel frame together with the cells is housed in a common sheet steel casing. The enclosure is powder coated and is designed to protect the capacitor cells from dust and moisture. Ease of mounting is ensured by 4 drillings at the bottom of the container.

This design ensures highest safety by:

- Self healing technology
- Over pressure tear - off fuse
- Robust steel container
- Massive connection studs

MPP Capacitors are manufactured in the following types - Standard Duty, Standard Duty Prime, Heavy Duty, Super Heavy Duty & Ultra Heavy Duty. The Standard Duty capacitors are manufactured using standard thickness of dielectric material with heavy edge metalization. Standard Duty Prime, Heavy Duty, Super Heavy Duty & Ultra Heavy Duty capacitors are manufactured using thicker material and in lower width which increases current handling capacity as well as reduces temperature.

The life of a capacitor is influenced by the following three parameters:

- Temperature
- Voltage
- Current

Temperature

For a capacitor, the temperature depends upon the following parameters:

- Ambient temperature at which capacitor is being operated
- Amount of over current that flows through the capacitor
- Power loss of the capacitor (dielectric power loss and resistive power loss)

The increase in temperature results in faster degradation of the dielectric. For every 10°C rise in temperature, the life of the capacitor is halved. Faster the degradation of the dielectric, lower will be the life of the capacitor.

Increase in temperature beyond a certain limit may result in expansion of impregnation and dielectric material. This may result in bulging of capacitors. In worst case, capacitor may even burst, if it does not have an over-pressure disconnecter.

The capacitor must thus be operated at rated ambient temperature for a long operating life.

Capacitors are classified in temperature categories, each category being specified by a number followed by a letter. The number represents the lowest ambient air temperature at which the capacitor may operate. The letters represent upper limits of temperature variation ranges.

Letter symbols for upper limit of temperature range as per IEC 60831 are as follows :

Symbol	Ambient Temperature (°C)		
	Maximum	Highest mean over any period of	
		24 h	1 year
A	40	30	20
B	45	35	25
C	50	40	30
D	55	45	35

Voltage

The increase in system voltage has the following effects on the capacitor:

■ Dielectric degradation

If the voltage increases beyond a certain limit, the dielectric material will breakdown. This critical voltage is called the dielectric breakdown voltage. Breakdown can result in an internal short circuit causing the capacitor to fail permanently.

■ Increase in current flow through the capacitor

As capacitors are linear in nature, with increase in voltage, the capacitor current also increases because X_c remains constant ($I_c = V/X_c$). This results in overloading of the capacitor, which may reduce the life of the capacitor. Over voltage limits of the capacitors are +10% for 8 hrs in 24 hrs, +15% for 30 min in 24h, +20% for 5 min in 24 hrs and +30% for 1 min in 24 hrs.

Current

The parameters that are related to current, which affect the life of the capacitor are:

■ Inrush current

Whenever the capacitor is switched on, it draws a huge inrush current which goes up to levels even greater than 100 times the capacitor rated current. Frequent switching of the capacitor without proper inrush current limiting devices will affect the life of the capacitor as it is heavily stressed during each switching operation. Switching frequency and amplitude of inrush current thus influences the life of the capacitor.

■ Over-load current

Continuous overload of capacitor is mainly because of harmonics and continuous over voltage. Overloading results in local hot spots and may lead to an internal short circuit.

To conclude, all the above parameters should be within the rated value in order to exploit the maximum life of the capacitor.

A capacitor is a passive device which has two conductors separated by a dielectric of infinite resistance, ideally. Hence, it should offer only capacitive reactance, with zero resistance and zero inductance values. But practically, the dielectric of the capacitor will offer a finite resistance along with the capacitance. This finite resistance is called as **Equivalent Series Resistance (ESR)**, and its equivalent circuit can be represented as below:

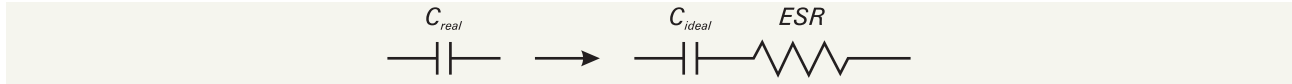

The ESR in the capacitor causes the leakage current to flow through the dielectric of the capacitor. This results in real power loss ($I^2 \times ESR$) called as dielectric loss. Higher the ESR, higher is the power loss, and hence the heat generated by the capacitor is also more. The heat generated should be dissipated properly; otherwise it may result in significant temperature rise. A good quality capacitor has very low ESR value.

In a lossless (ideal) capacitor, the current leads the voltage exactly by 90° . But there is always a small shortfall in the lead angle from 90° , because of the dielectric loss. The difference in angle is called loss angle (δ). The following diagram represents loss angle (δ) in the impedance plane.

The tangent of the loss angle (loss tangent) is defined as the ratio of the capacitor's equivalent series resistance (ESR) to the capacitive reactance (X_c).

Impedance plane

$$\tan \delta = \frac{ESR}{[X_c]} \longrightarrow \text{(Eq 1)}$$

Power loss = $I^2 \times ESR$

= $(\omega CV) \times (\omega CV) \times ESR$ where, $\omega = 2\pi f$

= $(\omega C) \times (\omega CV^2) \times ESR$

= $(\omega C) \times Q \times ESR$

= $Q \times ESR / X_c$

Power loss = $Q \tan \delta$ [from Eq 1]

Where, Q is the reactive power rating of the capacitor (in VAR).

Typically, for good quality power capacitors, $\tan \delta$ value is less than 0.0002. Power loss of any capacitor can be computed if $\tan \delta$ value is known as explained in the example below:

For a 10 kVAR capacitor, consider the value of $\tan \delta$ as 0.0002.

Total watt loss = $10 \times 1000 \times 0.0002$

= 2 watts

Per kVAR power loss = Total watt loss / kVAR

= $2/10$

= 0.2 watts per kVAR

Normally, the $\tan \delta$ value is available in the routine test certificate of the power capacitor.

The life of a power capacitor is largely dependent upon temperature. Hence, it is a good practice to do the thermal design of APFC panel after computing the capacitor power loss.

Typically, power factor correction capacitors are fitted with discharge resistors connected directly across the terminals (two resistors between three phases). These resistors are mandatory safety requirement recommended by the capacitor standards, to discharge the residual voltage that remains in the capacitor, once it is switched off.

As per IEC 60831 (MPP capacitors) and IEC 60931 (APP capacitors) the capacitor should discharge to 75 V or below within 3 min as soon as the capacitor is switched off. This is to protect human beings from the risk of electric shock and also for safe re-switching of the same capacitor in APFC panel. As a general practice, discharge resistors bring the voltage to below 50 V in 1 min, which is safer.



Cylindrical capacitor's terminal block with discharge resistor

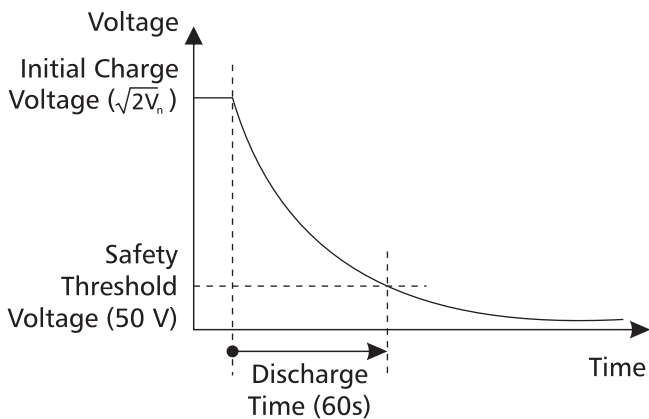

If the capacitor is re-switched without discharging sufficiently, there is a possibility that the voltage difference across the contactor may shoot up to 1000 V. More over, this results in very high peak inrush current as the rate of change of voltage is very high ($I_c = C \, dV/dt$). Such frequent switchings reduce the life of the capacitor and/or the contactor, and may cause premature failures. Hence while re-switching the capacitor (either in manual mode or auto mode) it is mandatory to discharge the capacitor to its 10% rated voltage.

In order to ensure the sufficient discharge, it should be ensured that the capacitor is re-switched only after 45 to 60 seconds. This time delay (for re-switching the same capacitor bank) can be set in APFC relay. In case, any application demands frequent switching of capacitors by contactors, time delay can be reduced by faster discharge of the residual voltage. Faster discharging can be achieved by replacing the existing resistors with new resistors of lesser resistance.

Formula to calculate the resistance is:

$$R \leq \frac{t}{3C \times \log_e \left(\frac{\sqrt{2}V_n}{V_r} \right)}$$

Where,

R = Discharge resistance value in Ω

t = time for discharge from $\sqrt{2}V_n$ (ie., peak voltage) to V_r (50 V), in seconds

C = Rated capacitance per phase, in μF

V_n = Rated voltage of capacitor unit, in V

V_r = Permissible residual voltage, in V

The above formula is valid for resistors assembly in the delta connected capacitor (two resistors between three terminals), as shown in the figure.

However, opting for lower resistance for faster discharge will increase the power loss. At the same time, appropriate power rating (wattage) of the resistor should be chosen to ensure sufficient current carrying capacity of the resistor.

$$\text{Power rating of the resistor (in watts)} = 1.3 V_n I = \frac{1.3 \times V_n^2}{R}$$

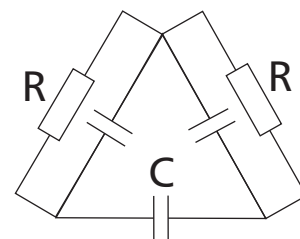

Here, the resistor should withstand the initial peak discharge current even if the capacitor is switched off at the instant of 30% over voltage.

The name plate of a capacitor usually has three kVAr ratings at three different voltages. kVAr rating of the capacitor is directly proportional to square of the applied voltage.

This is evident from the below formula:

$$kVAr = \frac{V^2}{X_c}$$

As capacitance (C in uF) remains same for a capacitor, X_c will remain constant.

For example, if a capacitor is rated for 30 kVAr at 480 V, and if the applied voltage is 440 V, the kVAr output can be calculated as follows:

$$\begin{aligned} kVAr \text{ output} &= \text{Rated kVAr} \times \frac{(\text{Applied voltage})^2}{(\text{Rated voltage})^2} \\ &= 30 \times \frac{(440)^2}{(480)^2} \\ &= 25.2 \text{ kVAr at 440 V} \end{aligned}$$

Similarly, if we apply 500 V for the same capacitor, the kVAr output will be 32.5 kVAr. In this case, we are applying voltage more than the rated value and the capacitor will deliver kVAr output more than its rated value. Hence the life of the capacitor may reduce drastically, because of over-voltage and over-current.

To summarize, the product label of a capacitor (for e.g. 30 kVAr, 480 V) has the following details as shown above.

Similarly, for 25 kVAr and 440 V capacitor, the name plate contains the respective kVAr ratings and current ratings at 440 V, 415 V and 400 V.

Selection of Capacitors When System Voltage is 415 V

Before deciding the voltage of the capacitor, it is important to understand the percentage impedance of the transformer (% Z). The percentage impedance is the voltage drop on full load due to the winding resistance and leakage reactance of the transformer. This is expressed as a percentage of the rated voltage. For example, if the secondary of the transformer is rated for 433 V and %Z is 4%, the voltage available at the load end, during full load conditions, would be 415 V only. When the load decreases, the voltage drop decreases and hence the voltage at the load end increases. During no-load conditions, the voltage can reach a maximum of 433 V.

If a capacitor is selected with 415 V (in the above case), it would be subjected to over-voltage during partial load or no-load conditions. This would impact the capacitor life drastically. For a normal capacitor, following are the over-voltage limits permitted as per IEC:

- 10% over-voltage for 8 hours in every 24 hours
- 15% over-voltage for 30 minutes in every 24 hours
- 20% over-voltage for 5 minutes in every 24 hours
- 30% over-voltage for 1 minute in every 24 hours

Hence, the capacitor should be rated for 440 V, even though the voltage at the load end is measured as 415 V. In general, it is a better practice to select capacitor voltage greater than the rated secondary voltage of the transformer and hence, avoid prolonged over-voltage conditions.

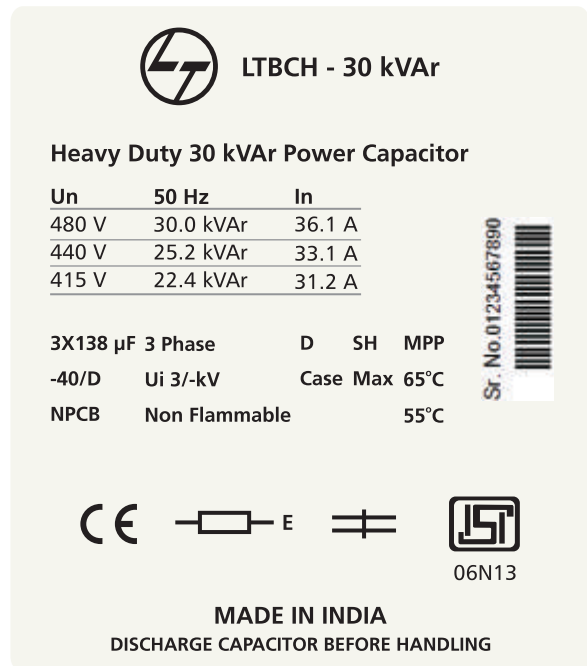

Capacitor label



L&T Electrical & Automation (E&A) Standard Duty Capacitors are metalized polypropylene capacitors from 1 - 33.1 kVAr in cylindrical configuration and 1-33.1 kVAr in box type configuration. These capacitors come with a stacked winding and are impregnated with a biodegradable soft resin. These capacitors are self healing type. The Capacitors come with an over pressure disconnecter and finger proof terminals. They can be used to provide effective power factor correction in industrial and semi industrial applications.

For Selection and Application details please refer page no. 113

Technical Details

	Standard Duty	
	Box	Cylindrical
Series	LTBCF (1 to 6 kVAr) and LTBCD (7.5 kVAr and above)	LTCCF (1 to 6 kVAr) LTCCD (7.5 kVAr above)
Range	1 - 33.1 kVAr	1 - 33.1 kVAr
Standards	IS 13340-2012, IS 13341-1992, IEC 60831-1+2	IS 13340-2012, IS 13341-1992, IEC 60831-1+2
Rated Frequency	50 Hz	50 Hz
Rated Voltage	440 / 480 / 525 V	440 / 480 / 525 V
Over Voltage	+10% (8h/24h), +15% (30m/24h), +20% (5m/24hrs), +30% (1m/24hrs)	+10% (8h/24h), +15% (30m/24h), +20% (5m/24hrs), +30% (1m/24hrs)
Overcurrent	1.5 x In	1.5 x In
Peak Inrush Current	200 x In	200 x In
Operating Losses (Dielectric)	≤ 0.2 W / kVAr	≤ 0.2 W / kVAr
Operating Losses (Total)	≤ 0.45 W / kVAr	≤ 0.45 W / kVAr
Tolerance on Capacitance	-5 / +10% as per IS	-5 / +10% as per IS
Test Voltage (Terminal-Terminal)	2.15 Times rated voltage for 10 sec	2.15 Times rated voltage for 10 sec
Test Voltage (Terminal-Casing)	3 kV (AC) for 1 minute	3 kV (AC) for 1 minute
Degree of Protection	IP20, Indoor mounting	IP20, Indoor mounting
Ambient Temperature	-25 / D Max temperature = +55°C Max mean temperature (24 h) = +45°C Max mean temperature (1 year) = +35°C	-25 / D Max temperature = +55°C Max mean temperature (24 h) = +45°C Max mean temperature (1 year) = +35°C
Cooling	Natural or forced air cooling	Natural or forced air cooling
Permissible Relative Humidity	Max 95%	Max 95%
Maximum Operating Altitude	4000 m above sea level	4000 m above sea level
Mounting	Upright	Upright
Safety Features	Overpressure disconnecter, Self-healing, Finger-proof terminals	Overpressure disconnecter, Self-healing, Finger-proof terminals
Impregnation	Non-PCB biodegradable resin	Non-PCB biodegradable resin
Casing	MS Sheet metal	Aluminum extruded can
Dielectric Composition	Metalized polypropylene	Metalized polypropylene
Terminals	Wire length 150mm (1 - 6 kVAr) Ceramic bushing (7.5 kVAr and above)	Wire length 150mm (1 - 6 kVAr) Finger-proof clamp type (7.5 kVAr and above)
Discharge Resistors / Time	Discharge resistors fitted, Standard discharge time 60 seconds	Discharge resistors fitted, Standard discharge time 60 seconds
Switching Operations (maximum)	5000 Switchings per year	5000 Switchings per year
Life*	1,00,000 hrs	1,00,000 hrs

*at standard operating conditions

Standard Duty Capacitors - Overall Dimensions

Cylindrical Type

1 kVAR to 6 kVAR

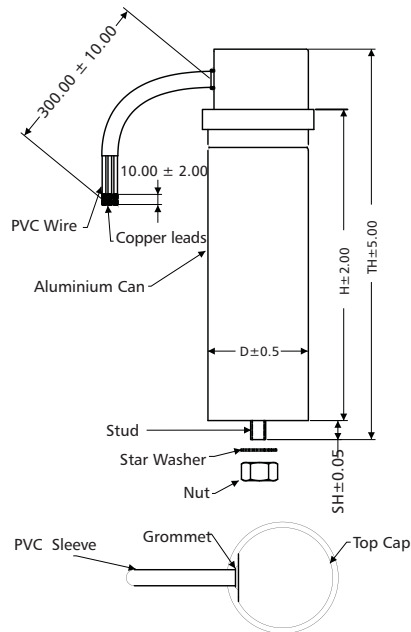

7.5 kVAR to 25 kVAR

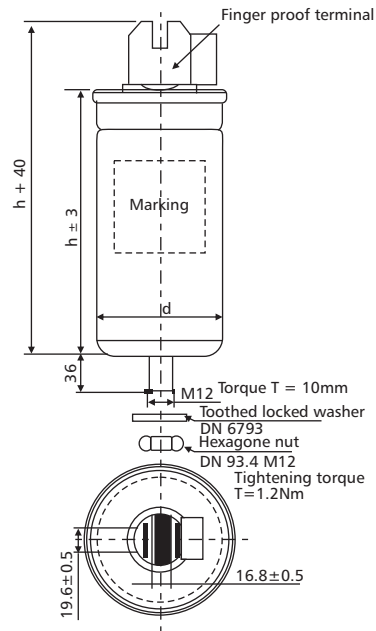

Note : 1) Seaming adds 4mm in diameter

Sr. No.	Voltage	Power Rating (kVAR)		Capacitance (μF)	Rated Current (A)	Dimensions in mm		Cat. No.
		50Hz	60Hz			H	D	
1	440 V	1	1	16.44	1.31	105	50	LTCCF301B2
2	440 V	2	2	32.88	2.62	125	50	LTCCF302B2
3	440 V	3	4	49.32	3.94	128	50	LTCCF303B2
4	440 V	4	5	65.77	5.25	150	63.5	LTCCF304B2
5	440 V	5	6	82.21	6.56	150	63.5	LTCCF305B2
6	440 V	6	7	98.65	7.87	185	63.5	LTCCF306B2
7	440 V	7.5	9	123.31	9.84	195	75	LTCCD307B2
8	440 V	8.33	10	136.96	10.93	195	75	LTCCD308B2
9	440 V	10	12	164.42	13.12	195	85	LTCCD310B2
10	440 V	12.5	15	205.52	16.40	270	85	LTCCD312B2
11	440 V	15	18	246.62	19.68	270	85	LTCCD315B2
12	440 V	20	24	328.83	26.24	345	85	LTCCD320B2
13	440 V	25	30	411.04	32.8	345	90	LTCCD325B2
14	480 V	1.2	1.4	8.28	1.44	105	50	LTCCF301C2
15	480 V	2.2	2.6	15.18	2.64	125	50	LTCCF302C2
16	480 V	3.3	4.0	22.77	3.96	128	50	LTCCF303C2
17	480 V	4.4	5.3	30.36	5.28	150	63.5	LTCCF304C2
18	480 V	5.5	6.6	37.95	6.6	150	63.5	LTCCF305C2
19	480 V	11.1	13.3	76.59	13.32	203	85	LTCCD311C2
20	480 V	13.8	16.6	95.22	16.56	278	75	LTCCD313C2
21	480 V	16.6	19.9	114.54	19.92	278	85	LTCCD316C2
22	480 V	22.1	26.5	152.49	26.52	278	90	LTCCD322C2
23	480 V	27.7	33.2	191.13	33.24	281	100	LTCCD327C2
24	525 V	1.3	1.6	7.51	1.43	125	50	LTCCF301M2
25	525 V	2.6	3.1	15.02	2.86	150	50	LTCCF302M2
26	525 V	3.9	4.7	22.52	4.29	150	63.5	LTCCF303M2
27	525 V	5.3	6.4	30.61	5.83	150	63.5	LTCCF305M2
28	525 V	6.6	7.9	38.12	7.26	155	75	LTCCF306M2
29	525 V	13.2	15.8	76.23	14.52	278	75	LTCCD313M2
30	525 V	16.6	19.9	95.87	18.26	278	85	LTCCD316M2
31	525 V	20	24	23.9	21.99	278	90	LTCCD320M2
32	525 V	26.5	31.8	153.04	29.15	281	100	LTCCD326M2
33	525 V	33.1	39.7	191.15	36.41	288	116	LTCCD333M2

Standard Duty Capacitors - Overall Dimensions

Box Type

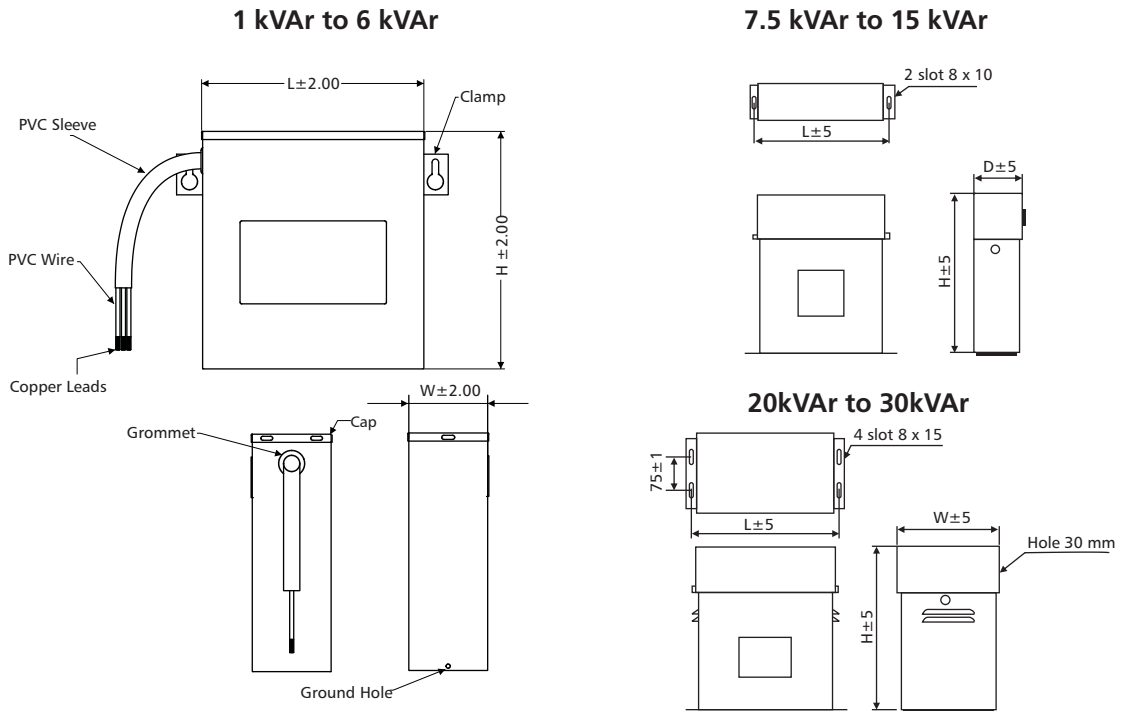

Sr. No.	Voltage	Power Rating (kVAR)		Capacitance (μ F)	Rated Current (A)	Dimensions in mm			Cat. No.
		50Hz	60Hz			L	W	H	
1	440 V	1	1	16.44	1.31	108	38	112	LTBCF301B2
2	440 V	2	2	32.88	2.62	108	38	112	LTBCF302B2
3	440 V	3	4	49.32	3.94	137	48	112	LTBCF303B2
4	440 V	4	5	65.77	5.25	137	48	112	LTBCF304B2
5	440 V	5	6	82.21	6.56	137	48	112	LTBCF305B2
6	440 V	6	7	98.65	7.87	137	48	112	LTBCF306B2
7	440 V	7.5	9	123.31	9.84	240	80	300	LTBCD307B2
8	440 V	8.33	10	136.96	10.93	240	80	300	LTBCD308B2
9	440 V	10	12	164.42	13.12	240	80	300	LTBCD310B2
10	440 V	12.5	15	205.52	16.40	240	80	300	LTBCD312B2
11	440 V	15	18	246.62	19.68	240	80	300	LTBCD315B2
12	440 V	20	24	328.83	26.24	240	160	300	LTBCD320B2
13	440 V	25	30	411.04	32.80	240	160	300	LTBCD325B2
14	440 V	30	36	493.25	39.37	240	160	300	LTBCD330B2
15	480 V	11.1	13.3	76.59	13.32	225	80	300	LTBCD311C2
16	480 V	13.8	16.6	95.22	16.56	225	80	300	LTBCD313C2
17	480 V	16.6	19.9	114.54	19.92	225	80	300	LTBCD316C2
18	480 V	22.1	26.5	152.49	26.52	225	160	300	LTBCD322C2
19	480 V	27.7	33.2	191.13	33.24	225	160	300	LTBCD327C2
20	525 V	13.2	15.8	76.23	14.52	225	80	300	LTBCD313M2
21	525 V	16.6	19.9	95.87	18.26	225	80	300	LTBCD316M2
22	525 V	20	24	23.9	21.99	225	90	278	LTBCD320M2
23	525 V	26.5	31.8	153.04	29.15	225	160	300	LTBCD326M2
24	525 V	33.1	39.7	191.15	36.41	225	160	300	LTBCD333M2

E&A's range of Standard duty capacitors with inbuilt MCB & LED are designed with metallized polypropylene technology and are available from 7.5 - 25 kVAr in Box configuration. These capacitors have all the features of Standard duty capacitors and are especially designed for industries where fixed compensation using Box type capacitors is preferred.

Instead of procuring capacitor, protection device & enclosure separately, these capacitors provide complete **3-in-1** solution:



1. Correction of PF using Standard duty capacitor.
2. Protection and isolation by integrated MCB.
3. LED in each capacitor phase giving a visual indication of health status of capacitor.

LED	Phase Status
Bright	Healthy
Dim	Derated
Dark	OFF (if MCB off)
	OPD has operated (if MCB is on)

Ease of Installation

We only need to make connections to the MCB through the top hole and then protect the terminals with the help of grommet after installing.

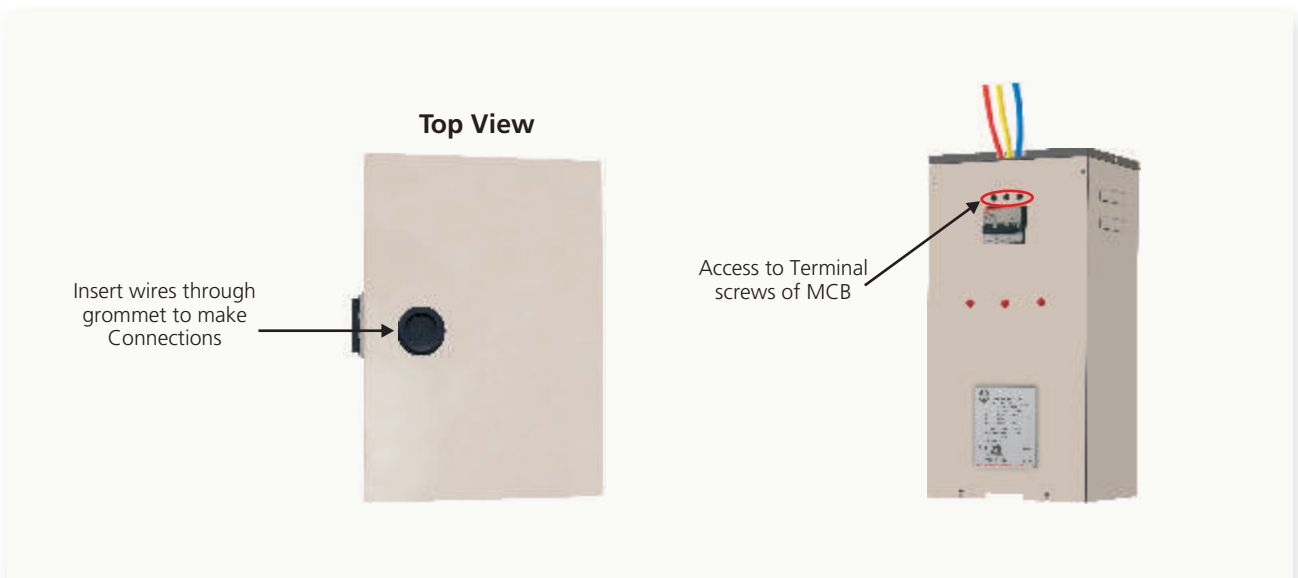

Standard duty Box with MCB & LED - Overall Dimensions

7.5 to 15 kVAr

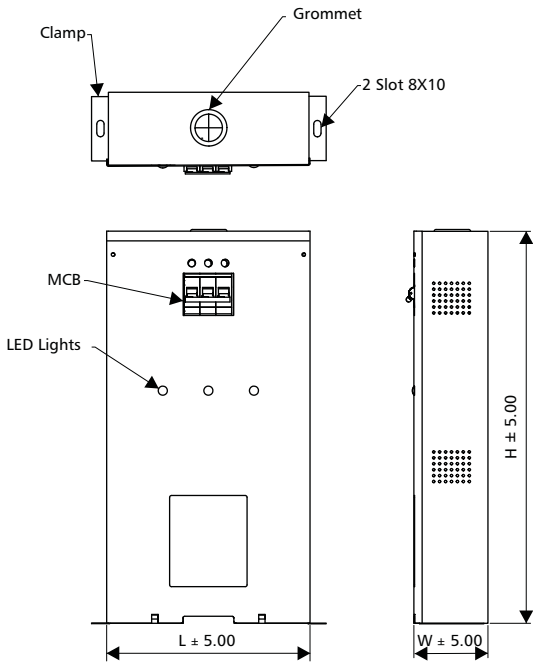

20 to 25 kVAr

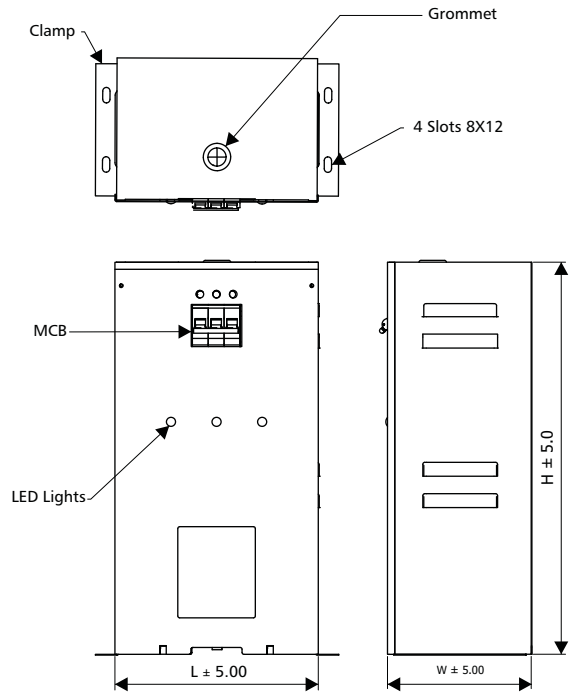

Sr. No.	Voltage	Power Rating (kVAr)		Capacitance (μF)	Rated Current (A)	Dimensions in mm			Cat. No.
		50Hz	60Hz			L	W	H	
1	440 V	5	6	82.17	6.56	220	75	430	LTBCM305B2
2	440 V	7.5	9	123.26	9.84	220	75	430	LTBCM307B2
3	440 V	8.33	10	136.90	10.93	220	75	430	LTBCM308B2
4	440 V	10	12	164.35	13.12	220	75	430	LTBCM310B2
5	440 V	12.5	15	205.44	16.40	220	75	430	LTBCM312B2
6	440 V	15	18	246.53	19.68	220	75	430	LTBCM315B2
7	440 V	20	24	328.83	26.24	220	155	430	LTBCM320B2
8	440 V	25	30	411.04	32.80	220	155	430	LTBCM325B2



E&A's Heavy Duty Capacitors are metalized polypropylene capacitors available from 1-33.1 kVAr in cylindrical and from 1-50 kVAr in box type construction. These capacitors have an inrush current withstand of 300 In and an overload withstand capacity of 1.8 In. These capacitors have all the features of standard capacitors like over pressure disconnecter and self healing.

For Selection and Application details please refer page no. 113

Technical Details

	Heavy Duty	
	Box	Cylindrical
Series	LTBCH	LTCCH
Range	1 - 50 kVAr	1 - 33.1 kVAr
Standards	IS 13340-1993, IS 13341-1992, IEC 60831-1+2	IS 13340-1993, IS 13341-1992, IEC 60831-1+2
Rated Frequency	50 Hz	50 Hz
Rated Voltage	440 / 480 / 525 V	440 / 480 / 525 V
Over Voltage	+10% (8h/24h), +15% (30m/24h), +20% (5m/24hrs), +30% (1m/24hrs)	+10% (8h/24h), +15% (30m/24h), +20% (5m/24hrs), +30% (1m/24hrs)
Overcurrent	1.8 x In	1.8 x In
Peak Inrush Current	300 x In	250 x In
Operating Losses (Dielectric)	≤ 0.2 W / kVAr	≤ 0.2 W / kVAr
Operating Losses (Total)	≤ 0.35 W / kVAr	≤ 0.5 W / kVAr
Tolerance on Capacitance	-5 / +10% as per IS	-5 / +10% as per IS
Test Voltage (Terminal-Terminal)	2.15 times rated voltage for 10 sec	2.15 times rated voltage for 10 sec
Test Voltage (Terminal-Casing)	3 kV (AC) for 1 minute	3 kV (AC) for 1 minute
Degree of Protection	IP20, indoor mounting	IP20, indoor mounting
Ambient Temperature	-25 / D Max temperature = +55°C Max mean temperature (24 h) = +45°C Max mean temperature (1 year) = +35°C	-40 / D Max temperature = +55°C Max mean temperature (24 h) = +45°C Max mean temperature (1 year) = +35°C
Cooling	Natural or forced air cooling	Natural or forced air cooling
Permissible Relative Humidity	Max 95%	Max 95%
Maximum Operating Altitude	4000 m above sea level	4000 m above sea level
Mounting	Upright	Upright
Safety Features	Overpressure disconnecter, Finger-proof terminals, Self-healing	Overpressure disconnecter, Finger-proof terminals, Self-healing
Impregnation	Non PCB biodegradable resin	Non PCB biodegradable resin
Casing	MS Sheet metal	Aluminum extruded can
Dielectric Composition	Metalized polypropylene	Metalized polypropylene
Terminals	Ceramic bushing	Fast-on terminals upto 5 kVAr Finger-proof clampite upto 33.1 kVAr
Discharge Resistors / Time Switching Operations (maximum)	Discharge resistors fitted, Standard discharge time 60 seconds	Discharge resistors fitted, Standard discharge time 60 seconds
Life*	8000 Switchings per year	7500 Switchings per year
	1,50,000 hrs	1,30,000 hrs

*at standard operating conditions

Heavy Duty Capacitors - Overall Dimensions

Cylindrical Type

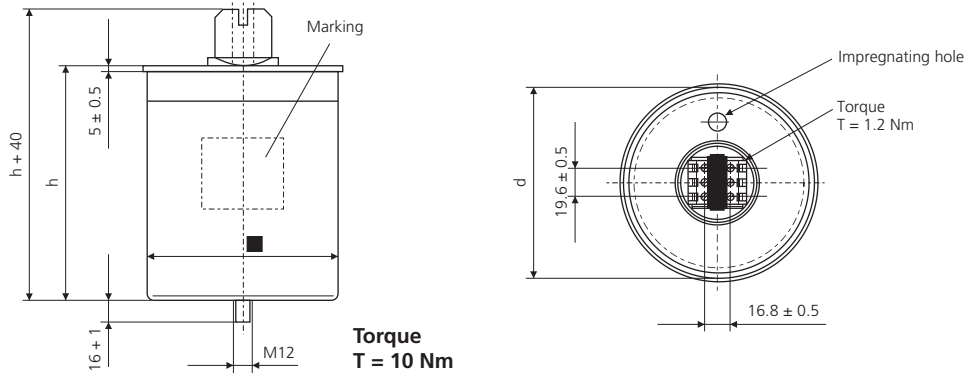

Sr. No.	Voltage	Power rating (kVAR)		Capacitance (μF)	Rated current (A)	Dimensions in (mm)		Cat. No.
		50 Hz	60 Hz			H	D	
1	440 V	1	1.2	16.44	1.30	117	53	LTCCH301B2
2	440 V	2	2.4	32.88	2.60	117	53	LTCCH302B2
3	440 V	3	3.6	49.32	3.90	117	53	LTCCH303B2
4	440 V	4	4.8	65.77	5.20	152	53	LTCCH304B2
5	440 V	5	6	82.21	6.60	152	53	LTCCH305B2
6	440 V	7.5	9	123.31	9.80	160	75	LTCCH307B2
7	440 V	10	12	164.42	13.10	197	75	LTCCH310B2
8	440 V	12.5	15	205.52	16.40	197	75	LTCCH312B2
9	440 V	15	18	246.62	19.70	270	75	LTCCH315B2
10	440 V	20	24	328.83	26.20	270	85	LTCCH320B2
11	440 V	25	30	411.04	32.80	270	90	LTCCH325B2
12	440 V	30	36	493.25	39.40	348	90	LTCCH330B2
13	480 V	5.5	6.6	75.99	6.60	152	63.5	LTCCH305C2
14	480 V	11.1	13.32	153.35	13.40	197	75	LTCCH311C2
15	480 V	13.8	16.56	190.65	16.60	270	75	LTCCH313C2
16	480 V	16.6	19.92	229.34	20.00	270	85	LTCCH316C2
17	480 V	22.1	26.52	305.32	26.60	348	85	LTCCH322C2
18	480 V	27.7	33.24	382.69	33.30	348	90	LTCCH327C2
19	525 V	6.6	7.92	76.22	7.30	160	75	LTCCH306M2
20	525 V	13.2	15.84	152.44	14.50	270	75	LTCCH313M2
21	525 V	16.6	19.92	191.71	18.30	270	85	LTCCH316M2
22	525 V	20	24	230.97	22.00	270	90	LTCCH320M2
23	525 V	26.5	31.8	306.04	29.10	348	90	LTCCH326M2
24	525 V	30	36	346.46	33.00	280	116	LTCCH330M2
25	525 V	33.1	39.72	382.26	36.40	280	116	LTCCH333M2

Heavy Duty Capacitors - Overall Dimensions

Box Type

5 to 12.5 kVAR

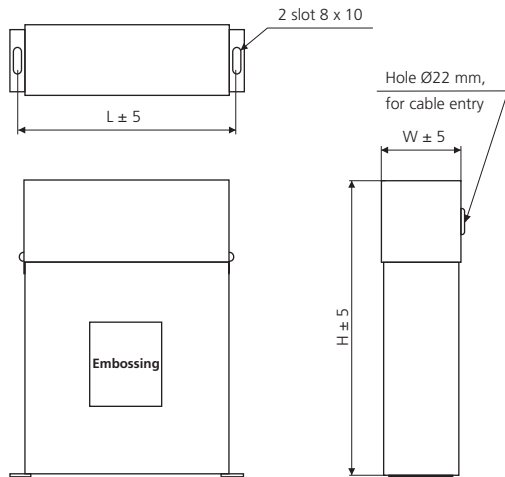

15 to 50 kVAR

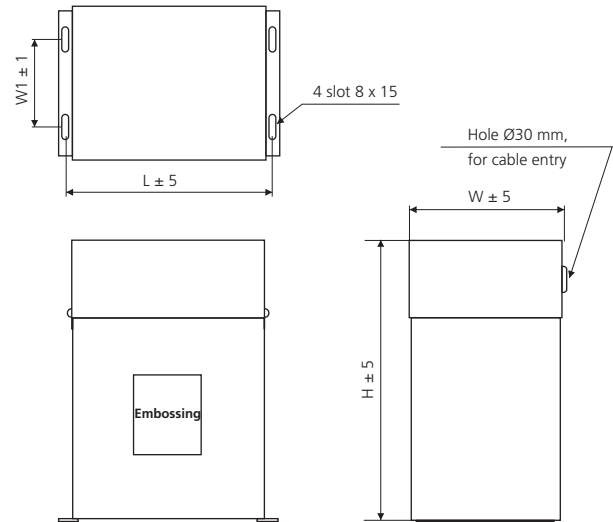

Sr. No.	Voltage	Power rating (kVAR)		Capacitance (μ F)	Rated current (A)	Dimensions in (mm)				Cat. No.
		50 Hz	60 Hz			L	W	W1	H	
1	440 V	1	1	16.44	1.31	125	45	-	170	LTBCH301B2
2	440 V	2	2	32.88	2.62	125	45	-	170	LTBCH302B2
3	440 V	3	4	49.32	3.94	185	60	-	240	LTBCH303B2
4	440 V	4	5	65.77	5.25	185	60	-	240	LTBCH304B2
5	440 V	5	6	82.21	6.56	240	80	-	300	LTBCH305B2
6	440 V	7.5	9	123.31	9.84	240	80	-	300	LTBCH307B2
7	440 V	8.33	10	136.96	10.93	240	80	-	300	LTBCH308B2
8	440 V	10	12	164.42	13.12	240	80	-	300	LTBCH310B2
9	440 V	12.5	15	205.52	16.40	240	80	-	300	LTBCH312B2
10	440 V	15	18	246.62	19.68	240	80	75	300	LTBCH315B2
11	440 V	20	24	328.83	26.24	240	160	75	300	LTBCH320B2
12	440 V	25	30	411.04	32.80	240	160	75	300	LTBCH325B2
13	440 V	30	36	493.25	39.37	240	160	75	300	LTBCH330B2
14	440 V	50	60	822.08	65.61	240	320	150	350	LTBCH350B2
15	480 V	5.5	6.6	90.43	9.92	240	80	-	300	LTBCH305C2
16	480 V	11.1	13.32	153.35	13.36	240	80	-	300	LTBCH311C2
17	480 V	15	18	207.23	18.04	240	80	75	300	LTBCH315C2
18	480 V	20	24	276.31	24.06	240	160	75	300	LTBCH320C2
19	480 V	25	30	345.39	30.07	240	160	75	300	LTBCH325C2
20	480 V	27.7	33.24	382.69	33.31	240	160	75	300	LTBCH327C2
21	525 V	6.6	7.92	76.22	7.26	240	80	-	300	LTBCH306M2
22	525 V	13.2	15.84	127.04	12.10	240	80	-	300	LTBCH313M2
23	525 V	15	18	173.23	16.50	240	80	75	300	LTBCH315M2
24	525 V	20	24	230.97	21.99	240	160	75	300	LTBCH320M2
25	525 V	25	30	288.72	27.49	240	160	75	300	LTBCH325M2
26	525 V	30	36	346.46	32.99	240	160	75	300	LTBCH330M2
27	525 V	33.1	40	382.26	36.40	240	160	75	300	LTBCH333M2



E&A's gas filled capacitors are metallised polypropylene capacitors available from 3-30 kVAr in cylindrical configuration. These capacitors have an inrush withstand of 250 times I_n and an overload withstand capacity of 1.8 times I_n . These capacitors have safety features like over pressure disconnecter and self healing.

The gas filled capacitors are subjected to an extended period of drying after which the casing is filled with an inert gas to prevent corrosion of the winding elements and inner electrical contacts. Compact design ensures space saving. Gas Filled capacitors have a long life of 150000 hours.

For Selection and Application details please refer page no. 113

Technical Details

	Gas Filled Capacitors
Series	LTCCN
Range	3 - 30 kVAr
Standards	IS 13340-1993, IS 13341-1992, IEC 60831-1+2
Rated Frequency	50 Hz
Rated Voltage	440 / 480 / 525 V
Over Voltage	+10% (8h/24h), +15% (30m/24h), +20% (5m/24hrs), +30% (1m/24hrs)
Overcurrent	1.8 x I_n
Peak Inrush Current	250 x I_n
Operating Losses (Dielectric)	≤ 0.2 W / kVAr
Operating Losses (Total)	≤ 0.35 W / kVAr
Tolerance on Capacitance	-5 / +10% as per IS
Test Voltage (Terminal-Terminal)	2.15 times rated voltage for 10 sec
Test Voltage (Terminal-Casing)	3 kV (AC) for 1 minute
Degree of Protection	IP20, indoor mounting
Ambient Temperature	-40 / D Max temperature = +55°C Max mean temperature (24 h) = +45°C Max mean temperature (1 year) = +35°C
Cooling	Natural or forced air cooling
Permissible Relative Humidity	Max 95%
Maximum Operating Altitude	4000 m above sea level
Mounting	Upright
Safety Features	Overpressure disconnecter, Finger-proof terminals, Self-healing
Impregnation	Non PCB biodegradable resin
Casing	Aluminum extruded can
Dielectric Composition	Metallized polypropylene
Terminals	Finger-proof clamptype
Discharge Resistors / Time	Discharge resistors fitted, Standard discharge time 60 seconds
Switching Operations (maximum)	8000 Switchings per year
Life*	1,50,000 hrs

*at standard operating conditions

Gas Filled Capacitors – Overall Dimensions

Cylindrical Type

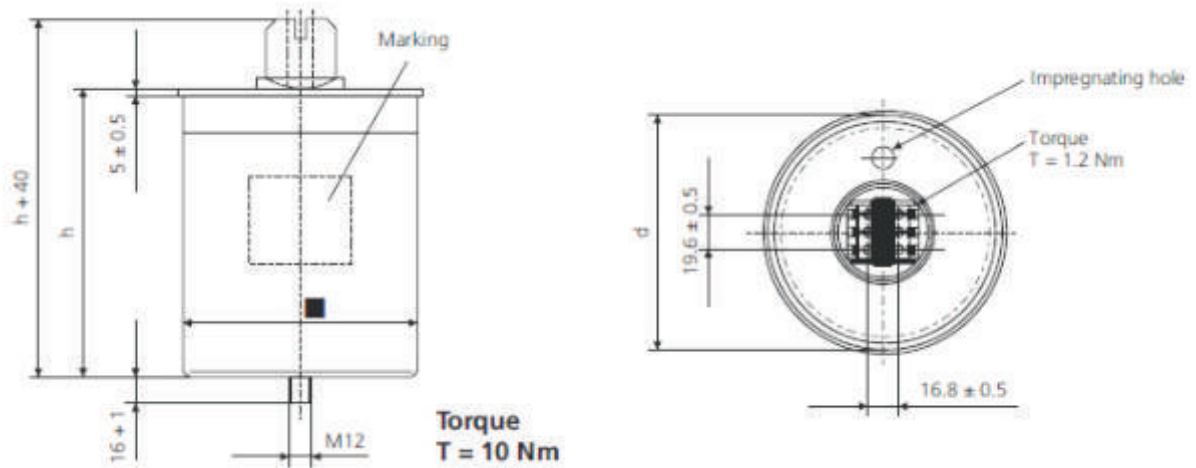

Sr. No.	Voltage	Power rating (kVAr)		Capacitance (μF)	Rated current (A)	Dimensions in (mm)		Cat. No.
		50 Hz	60 Hz			H	D	
1	440 V	3	3.6	49.32	3.94	130	64	LTCCN303B2
2	440 V	4	4.8	65.77	5.25	190	64	LTCCN304B2
3	440 V	5	6	82.21	6.56	190	64	LTCCN305B2
4	440 V	7.5	9	123.31	9.84	190	64	LTCCN307B2
5	440 V	8.33	10	136.96	10.93	190	64	LTCCN308B2
6	440 V	10	12	164.42	13.12	265	64	LTCCN310B2
7	440 V	12.5	15	205.52	16.40	265	64	LTCCN312B2
8	440 V	15	18	246.62	19.68	190	84.4	LTCCN315B2
9	440 V	20	24	328.83	26.24	265	84.4	LTCCN320B2
10	440 V	25	30	411.04	32.80	265	84.4	LTCCN325B2
11	480 V	7.5	9	103.62	9.02	190	64	LTCCN307C2
12	480 V	12.5	15	172.69	15.04	190	84	LTCCN312C2
13	480 V	15	18	207.23	18.04	265	84	LTCCN315C2
14	480 V	20	24	276.31	24.06	265	84	LTCCN320C2
15	480 V	25	30	345.39	30.07	265	84	LTCCN325C2
16	480 V	30	36	414.47	36.08	230	116	LTCCN330C2
17	525 V	7.5	9	86.61	8.25	190	64	LTCCN307M2
18	525 V	8.33	10	96.20	9.16	190	64	LTCCN308M2
19	525 V	12.5	15	144.36	13.75	265	65	LTCCN312M2
20	525 V	15	18	173.23	16.50	265	65	LTCCN315M2
21	525 V	20	24	230.97	21.99	265	84	LTCCN320M2
22	525 V	25	30	288.72	27.49	265	84	LTCCN325M2
23	525 V	30	36	346.46	32.99	230	116	LTCCN330M2



E&A's Super Heavy Duty Capacitors are designed and developed to meet reactive power requirements of modern day industries having higher harmonics. These metalized polypropylene capacitors ranges from 1.2-33.3 kVAr with cylindrical type construction. They can withstand peak inrush current of 350 times the rated and an overload withstand capacity of 2.5 times rated current. They have better harmonic withstand capability and long life along with necessary safety features like over pressure disconnecter and self-healing technology.

For Selection and Application details please refer page no. 113

Technical Details

	Super Heavy Duty
	Cylindrical
Series	LTCCR
Range	1.2 - 33.3 kVAr
Standards	IEC 60831-1+2
Rated frequency	50 Hz
Rated Voltage	440 / 480 / 525 V
Over Voltage	+10% (8h/24h), +15% (30m/24h), +20%(5m/24h), +30% (1m/24h)
Over current	2.5 x In
Peak Inrush Current	350 x In
Operating Losses (Dielectric)	≤ 0.2 W / kVAr
Operating Losses (Total)	≤ 0.45 W / kVAr
Tolerance on capacitance	-5% to +5%
Test Voltage (Terminal-Terminal)	2.15 times rated voltage for 2 s
Test voltage (Terminal-Casing)	5 kV (AC) for 10 s
Degree of protection	IP20
Ambient Temperature	-40°C to 65°C
Cooling	Natural or Forced Air Cooling
Permissible Relative Humidity	Max 95%
Maximum Operating Altitude	4000 m above mean sea level
Mounting	Universal
Safety features	Overpressure Disconnection System, Finger-proof terminals
Impregnation	Non-PCB biodegradable polyurethane self-extinguishing resin
Casing	Aluminum case with bottom fixing M12 x 16
Dielectric Composition	Metalized Polypropylene
Terminals	Optimized capacitor safety terminals with electric shock protection IP20
Discharge Resistors/Time	Discharge resistors fitted. Standard discharge time 60 seconds.
Switching Operations (maximum)	15000 switchings per year
Life*	2,00,000 hrs

*at standard operating conditions

Super Heavy Duty Capacitors - Overall Dimensions

Cylindrical Type

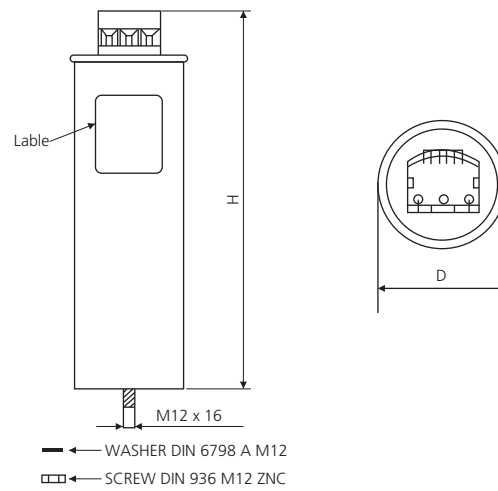

Sr. No.	Voltage (V)	Power Rating (kVAr)		Capacitance (μF)	Rated Current (A)	Dimensions (mm)		Cat. No.
		50 Hz	60 Hz			H	D	
1	440 V	3	4	49.32	3.94	260	70	LTCCR303B2
2	440 V	4	4.8	65.76	5.25	260	70	LTCCR304B2
3	440 V	5	6	82.21	6.56	260	70	LTCCR305B2
4	440 V	7.5	9	123.31	9.84	260	85	LTCCR307B2
5	440 V	8.33	10	136.96	10.93	260	85	LTCCR308B2
6	440 V	10	12	164.42	13.12	260	85	LTCCR310B2
7	440 V	12.5	15	205.52	16.40	260	100	LTCCR312B2
8	440 V	15	18	246.62	19.68	260	100	LTCCR315B2
9	440 V	20	24	328.83	26.24	265	120	LTCCR320B2
10	440 V	25	30	411.04	32.80	265	136	LTCCR325B2
11	480 V	1.2	1.4	19.73	2.16	260	70	LTCCR301C2
12	480 V	2.2	2.6	36.17	3.97	260	70	LTCCR302C2
13	480 V	3.3	4.0	54.26	5.95	260	70	LTCCR303C2
14	480 V	4.4	5.3	72.34	7.94	260	70	LTCCR304C2
15	480 V	5.5	6.6	90.43	9.92	260	85	LTCCR305C2
16	480 V	11.1	13.32	153.35	13.36	260	100	LTCCR311C2
17	480 V	15	18	207.23	18.04	265	120	LTCCR315C2
18	480 V	20	24	276.31	24.06	265	120	LTCCR320C2
19	480 V	25	30	345.39	30.07	265	136	LTCCR325C2
20	480 V	27.7	33.24	382.69	33.31	265	136	LTCCR327C2
21	525 V	1.3	1.6	15.01	1.43	260	70	LTCCR301M2
22	525 V	2.6	3.1	30.03	2.86	260	70	LTCCR302M2
23	525 V	3.9	4.7	45.04	4.29	260	70	LTCCR303M2
24	525 V	5	6	57.74	5.49	260	85	LTCCR305M2
25	525 V	6.6	7.9	76.22	7.26	260	85	LTCCR306M2
26	525 V	13.2	15.84	127.04	12.10	260	100	LTCCR313M2
27	525 V	15	18	173.23	16.50	265	120	LTCCR315M2
28	525 V	20	24	230.97	21.99	265	120	LTCCR320M2
29	525 V	25	30	288.72	27.49	265	136	LTCCR325M2
30	525 V	30	36	346.46	32.99	265	136	LTCCR330M2
31	525 V	33.3	40	384.57	36.62	310	136	LTCCR333M2



APP range of capacitors are Aluminium Polypropylene Capacitors available from 5-50 kVAr in Box type construction. Each capacitor element is protected by an internal fuse which in case of short circuit will blow and isolate that particular capacitor element. These are compact and suitable for applications with heavy load fluctuations and high inrush current.

For Selection and Application details, please refer page no. 113

Technical Details

	LT - APP
	Box
Series	LTBCP
Range	5 - 50 kVAr
Standards	IS-13585 (Part 1):2012 / IEC-60931-1:1996
Rated Frequency	50 Hz
Rated Voltage	440 / 480 / 525 V
Over Voltage	+10% (8h/24h), +15% (30m/24h), +20% (5m/24h), +30% (1m/24h)
Overcurrent	2.5 x In
Peak Inrush Current	300 x In
Operating Losses (Dielectric)	≤ 0.2 W/kVAr
Operating Losses (Total)	≤ 0.5 W/kVAr
Tolerance on Capacitance	-5 to +10% as per IS
Test Voltage (Terminal-Terminal)	2.15 times rated (AC) voltage for 10 s
Test Voltage (Terminal-Casing)	3 kV (AC) for 60 s
Degree of Protection	IP20
Ambient Temperature	-5 / D Max temperature = +55°C Max mean temperature (24 h) = +45°C Max mean temperature (1 year) = +35°C
Cooling	Natural or forced air cooling
Permissible Relative humidity	Max. 95%
Maximum Operating Altitude	Up to 1000m up to 12.5 kVAr Up to 2000m above 12.5 kVAr
Mounting	Upright
Safety Features	Internal fuse element
Impregnation	Non PCB, biodegradable oil
Casing	MS sheet metal
Dielectric Composition	Biaxially oriented polypropylene (BOPP) film
Terminals	Ceramic bushing, Terminal M-6 threaded for 5 - 15 kVAr Terminal M-10 threaded for 20 - 50 kVAr
Discharge Resistors/Time	Discharge resistors fitted. Standard discharge time 60 seconds.
Max Switching Operations	10,000 switching per year
Life*	2,00,000 hours

*at standard operating conditions

APP Capacitors - Overall Dimensions

Box Type

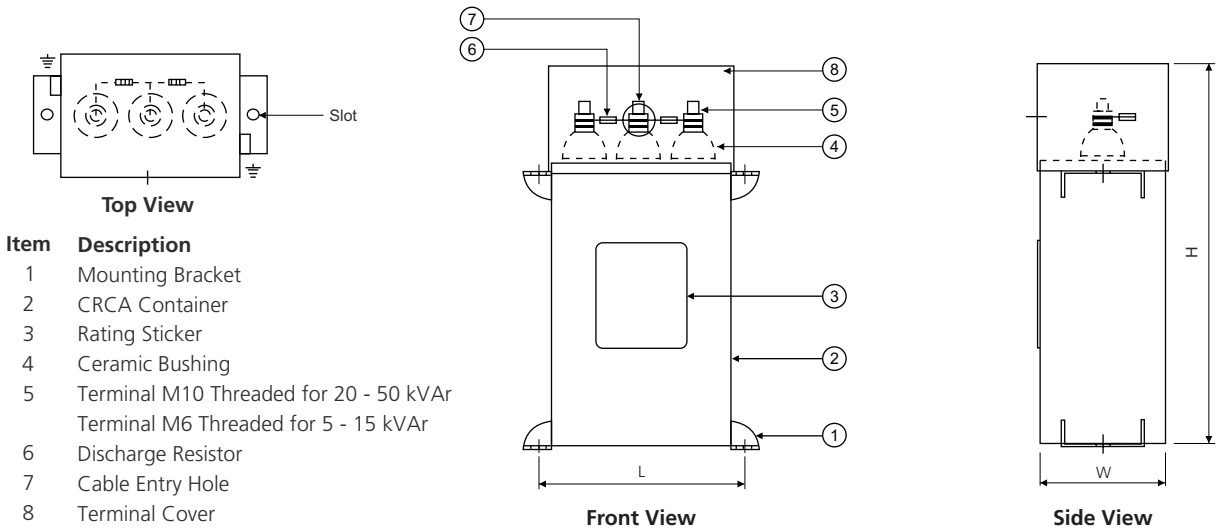

- | Item | Description |
|------|--|
| 1 | Mounting Bracket |
| 2 | CRCA Container |
| 3 | Rating Sticker |
| 4 | Ceramic Bushing |
| 5 | Terminal M10 Threaded for 20 - 50 kVAr |
| | Terminal M6 Threaded for 5 - 15 kVAr |
| 6 | Discharge Resistor |
| 7 | Cable Entry Hole |
| 8 | Terminal Cover |

Sr. No.	Voltage (V)	Power Rating (kVAr)		Capacitance (μ F)	Rated Current (A)	Dimensions (in mm)				Cat. No.
		50 Hz	60 Hz			L	W	H	Hole	
1	440 V	5	6	82.21	6.56	135	75	330	15 \emptyset	LTBCP305B2
2	440 V	7.5	9	123.31	9.84	135	85	330	15 \emptyset	LTBCP307B2
3	440 V	10	12	164.42	13.12	135	115	330	15 \emptyset	LTBCP310B2
4	440 V	12.5	15	205.52	16.4	155	115	330	15 \emptyset	LTBCP312B2
5	440 V	15	18	246.62	19.68	175	115	330	15 \emptyset	LTBCP315B2
6	440 V	20	24	328.83	26.24	225	115	355	30 \emptyset	LTBCP320B2
7	440 V	25	30	411.04	32.8	195	115	455	30 \emptyset	LTBCP325B2
8	440 V	50	60	822.08	65.61	335	115	455	30 \emptyset	LTBCP350B2
9	480 V	5.5	6.6	75.99	6.62	135	75	330	15 \emptyset	LTBCP305C2
10	480 V	11.1	13.3	153.35	13.35	135	115	330	15 \emptyset	LTBCP311C2
11	480 V	13.8	16.6	190.65	16.6	155	115	330	15 \emptyset	LTBCP313C2
12	480 V	16.6	19.9	229.34	19.97	175	115	330	15 \emptyset	LTBCP316C2
13	480 V	22.1	26.5	305.32	26.58	210	115	355	30 \emptyset	LTBCP322C2
14	480 V	27.7	33.2	382.69	33.32	185	115	455	30 \emptyset	LTBCP327C2
15	525 V	6.6	7.9	76.22	7.26	155	115	230	15 \emptyset	LTBCP306M2
16	525 V	13.2	15.8	152.44	14.52	135	115	330	15 \emptyset	LTBCP313M2
17	525 V	16.6	19.9	191.71	18.26	175	115	330	15 \emptyset	LTBCP316M2
18	525 V	20	24	230.97	21.99	195	115	355	30 \emptyset	LTBCP320M2
19	525 V	26.5	31.8	306.04	29.14	245	115	355	30 \emptyset	LTBCP326M2
20	525 V	30	36	346.46	32.99	195	115	455	30 \emptyset	LTBCP330M2
21	525 V	33.1	39.7	382.26	36.4	210	115	455	30 \emptyset	LTBCP333M2



E&A's LTXL Ultra Heavy duty cylindrical capacitors, like their box counterparts, are sturdy & specially designed to work in very heavy duty applications and high harmonics. They have an inrush current withstand capability of 500 times the rated and an overload withstands capacity of 3 times the rated. In modern industries with high harmonics and high switching rates, it can be an effective solution and delivers long life. It has all necessary safety features of standard capacitors like over pressure disconnecter and self-healing technology.

For Selection and Application details, please refer page no. 113

Technical Details

	LTXL: Ultra Heavy Duty
	Cylindrical
Series	LTCCU
Range	5 - 25 kVAr
Standards	IEC 60831-1+2, EN 60831-1+2
Rated frequency	50 Hz
Rated Voltage	440 / 480 / 525 V
Over Voltage	+10% (8h/24h), +15% (30m/24h), 20% (5m/24h), +30% (1m/24h)
Overcurrent	3 x In
Peak Inrush Current	500 x In
Operating Losses (Dielectric)	≤ 0.2 W / kVAr
Operating Losses (Total)	≤ 0.45 W / kVAr
Tolerance on capacitance	-5% to + 5%
Test Voltage (Terminal-Terminal)	2.15 times rated voltage for 2 s
Test voltage (Terminal-Casing)	5 kV (AC) for 1 min.
Degree of protection	IP20
Ambient Temperature	-40°C to 65°C
Cooling	Natural or Forced Air Cooling
Permissible Relative Humidity	Max. 95%
Maximum Operating Altitude	4000 m above mean sea level
Mounting	Universal
Safety features	Overpressure Disconnection System, Finger-proof terminals
Impregnation	Non-PCB biodegradable Polyurethane self-extinguishing resin
Casing	Aluminum case with bottomfixing M12 x 16
Dielectric Composition	Metalized Polypropylene
Terminals	Optimized capacitor safety terminals with electric shock protection IP20
Discharge Resistors/Time	Discharge resistors fitted. Standard discharge time 60 seconds.
Switching Operations (maximum)	18000 switchings per year
Life	3,00,000 hrs

LTXL: Ultra Heavy Duty Capacitors - Overall Dimensions

Cylindrical Type

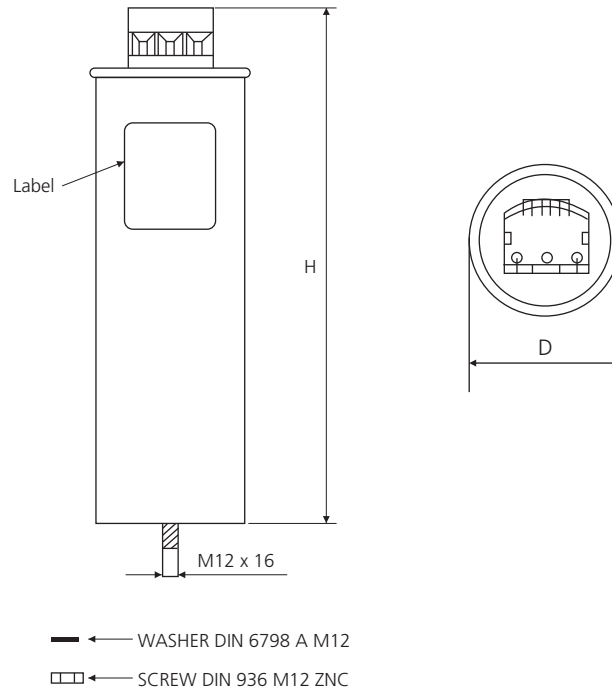

Sr. No.	Voltage (V)	Power Rating (kVAr)		Capacitance (μF)	Rated Current (A)	Dimensions (mm)		Cat. No.
		50 Hz	60 Hz			H	D	
1	440 V	5	6	82.21	6.56	395	70	LTCCU305B2
2	440 V	7.5	9	123.31	9.84	395	85	LTCCU307B2
3	440 V	8.33	10	136.96	10.93	395	85	LTCCU308B2
4	440 V	10	12	164.42	13.12	395	100	LTCCU310B2
5	440 V	12.5	15	205.52	16.40	395	100	LTCCU312B2
6	440 V	15	18	246.62	19.68	400	120	LTCCU315B2
7	440 V	20	24	328.83	26.24	400	120	LTCCU320B2
8	440 V	25	30	411.04	32.80	400	136	LTCCU325B2
9	480 V	7.5	9	103.62	9.02	395	85	LTCCU307C2
10	480 V	8.33	10	115.08	10.02	395	100	LTCCU308C2
11	480 V	10	12	138.16	12.03	395	100	LTCCU310C2
12	480 V	12.5	15	172.69	15.04	400	120	LTCCU312C2
13	480 V	15	18	207.23	18.04	400	120	LTCCU315C2
14	480 V	20	24	276.31	24.06	400	136	LTCCU320C2
15	525 V	7.5	9	86.61	8.25	395	100	LTCCU307M2
17	525 V	10	12	115.49	11.00	395	100	LTCCU310M2
18	525 V	12.5	15	144.36	13.75	400	120	LTCCU312M2
19	525 V	15	18	173.23	16.50	400	120	LTCCU315M2
20	525 V	20	24	230.97	21.99	400	136	LTCCU320M2

The LTXL range of capacitors are designed for Ultra heavy duty applications and can withstand heavy load fluctuations, high inrush current and harmonics.

Applications

- Applications such as welding, steel rolling, etc., with heavy load fluctuations and high thermal loading
- Systems with high harmonic distortion levels
- Systems with high inrush current



Features

- Long life expectancy (upto 300000 hrs)
- Maximum inrush current withstand capability (upto 500 times I_R)
- Low power loss (0.35 W / kVAr)
- Protection with internal fuse

The life of a capacitor largely depends upon its operating temperature. LTXL box type capacitors use **advanced APP** technology. By employing thicker aluminum foil, thicker hazy polypropylene film and special impregnates, LTXL box type capacitor is able to operate at lower temperatures and hence achieve a longer life. These capacitors are thus able to withstand stringent operating conditions. The higher surface area and special epoxy based coating also ensures better heat dissipation. The capacitor is designed to operate at case temperature up to 70°C.

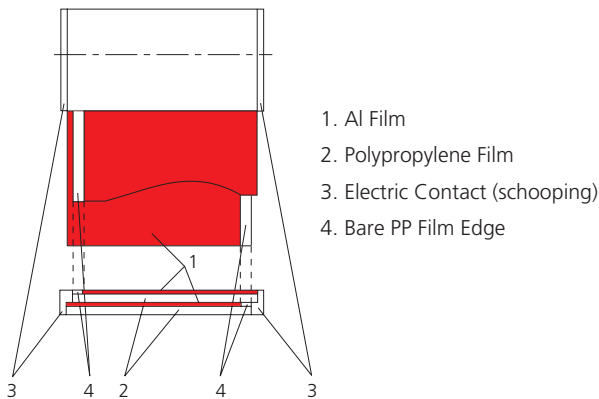

In LTXL box, two polypropylene films and two Al films are grouped together as shown in the figure. The wave-cut and heavy edge metalized films are then rolled to form a capacitor element. Many such capacitor elements are pressed and stacked together and are internally connected in parallel. Depending upon the rating of the capacitor, the number of stacks differ. These stacks are placed inside a case and are vacuum impregnated with non-PCB, biodegradable oil (PXE).

Each capacitor element is protected by an internal fuse as shown in the figure. If there is an internal short circuit in any of the capacitor element, the fuse of that corresponding capacitor element blows.

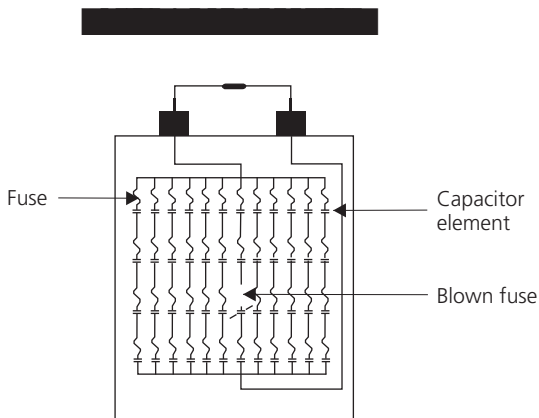

For Selection and Application details please refer page no. 113

Technical Details

	LTXL - Ultra Heavy Duty
	Box
Series	LTBCU
Range	5 - 50 kVAr
Standards	IS 13585 (Part 1)-2012, IEC 60931-1 1996
Rated Frequency	50 Hz
Rated Voltage	440 / 480 / 525 V
Over Voltage	+10% (8h/24h), +15% (30m/24h), +20% (5m/24hrs), +30% (1m/24hrs)
Overcurrent	3 x In
Peak Inrush Current	500 x In
Operating Losses (Dielectric)	≤ 0.2 W / kVAr
Operating Losses (Total)	≤ 0.35 W / kVAr
Tolerance on Capacitance	-5 / +10% as per IS
Test Voltage (Terminal-Terminal)	2.15 times rated voltage for 10 sec
Test Voltage (Terminal-Casing)	3 kV (AC) for 1 minute
Degree of Protection	IP20, Indoor mounting
Ambient Temperature	-25 / D (Case temperature 70°C)
Cooling	Natural or forced air cooling
Permissible Relative Humidity	Max 95%
Maximum Operating Altitude	4000 m above sea level
Mounting	Upright
Safety Features	Internal fuse
Impregnation	Non-PCB PXE oil
Casing	MS sheet metal with special black Epoxy coating
Dielectric Composition	Biaxially oriented polypropylene film with aluminium foil electrode
Terminals	Ceramic bushing
Discharge Resistors / Time	Discharge resistors fitted, Standard discharge time 60 seconds
Switching operations (maximum)	20000 Switchings per year
Life*	3,00,000 hrs

*at standard operating conditions

LTXL: Ultra Heavy Duty Capacitors - Overall Dimensions

Box Type

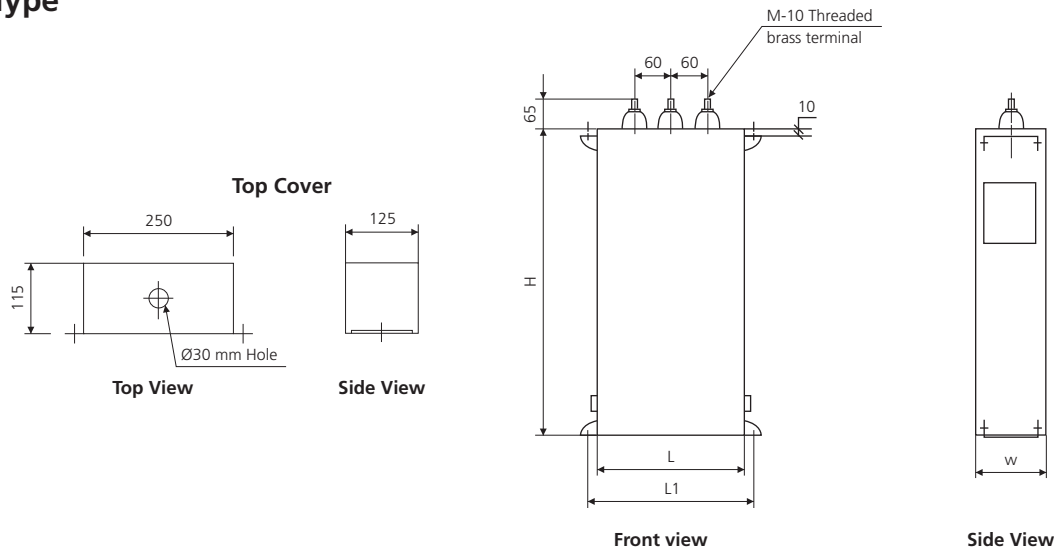

Sr. No.	Voltage	Power rating (kVAr)		Capacitance (µF)	Rated current (A)	Dimensions in (mm)				Cat. No.
		50 Hz	60 Hz			L	L1	W	H	
1	440 V	5	6	82.21	6.56	240	270	115	115	LTBCU305B2
2	440 V	7.5	9	123.31	9.84	240	270	115	150	LTBCU307B2
3	440 V	8.33	10	136.96	10.93	240	270	115	150	LTBCU308B2
4	440 V	10	12	164.42	13.12	240	270	115	175	LTBCU310B2
5	440 V	12.5	15	205.52	16.40	240	270	115	200	LTBCU312B2
6	440 V	15	18	246.62	19.68	240	270	115	225	LTBCU315B2
7	440 V	20	24	328.83	26.24	240	270	115	275	LTBCU320B2
8	440 V	25	30	411.04	32.80	240	270	115	325	LTBCU325B2
9	440 V	30	36	493.25	39.37	240	270	115	375	LTBCU330B2
10	440 V	50	60	822.08	65.61	240	270	115	575	LTBCU350B2
11	480 V	7.5	9	103.62	9.02	240	270	115	150	LTBCU307C2
12	480 V	10	12	138.16	12.03	240	270	115	150	LTBCU310C2
13	480 V	12.5	15	172.69	15.04	240	270	115	175	LTBCU312C2
14	480 V	15	18	207.23	18.04	240	270	115	200	LTBCU315C2
15	480 V	20	24	276.31	24.06	240	270	115	250	LTBCU320C2
16	480 V	25	30	345.39	30.07	240	270	115	300	LTBCU325C2
17	480 V	30	36	414.47	36.09	240	270	115	325	LTBCU330C2
18	525 V	7.5	9	86.61	8.25	340	370	115	115	LTBCU307M2
20	525 V	12.5	15	144.36	13.75	340	370	115	150	LTBCU312M2
21	525 V	15	18	173.23	16.50	340	370	115	175	LTBCU315M2
22	525 V	20	24	230.97	21.99	340	370	115	200	LTBCU320M2
23	525 V	25	30	288.72	27.49	340	370	115	250	LTBCU325M2
24	525 V	30	36	346.46	32.99	340	370	115	275	LTBCU330M2
25	525 V	33.1	40	382.26	36.40	340	365	115	325	LTBCU333M2



Harmonics is defined as a component of periodic wave (or a signal) whose frequency is integral multiple of the fundamental frequency. Non linear loads such as rectifiers, inverters, variable speed drives, furnaces, etc. create harmonics.

These currents consist of a fundamental frequency component rated at 50 Hz, plus a series of overlapping currents, with frequencies that are multiples of the fundamental frequency. The result is deformation of the current (and, as a consequence, voltage) that has a series of associated secondary effects.

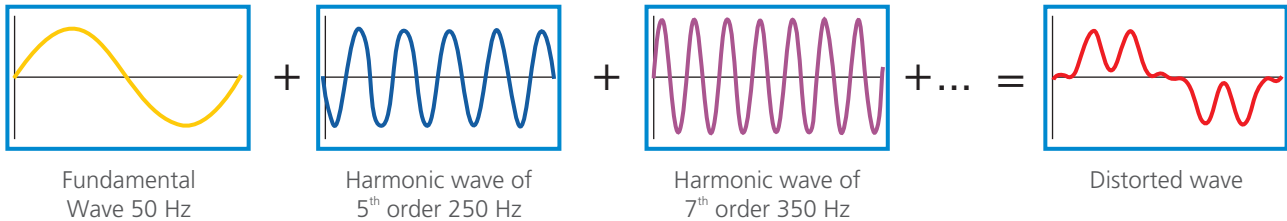

Types of Harmonic Loads

Type of Load	Wave Shape	Harmonic Spectrum THD - I
<ul style="list-style-type: none"> • 6 Pulse and 12 Pulse drive* (VFD & UPS) • Three-phase / Single-phase rectifiers • Arc / Induction furnace 		
<ul style="list-style-type: none"> • Discharge lamps / CFL • Single-phase converters • Computer, IT loads • SMPs • TVs 		

* Higher the number of pulses, lesser is the harmonic distortion

III Effects of Harmonics

Type of Equipment	Effect of Harmonics
Rotating Machines	Increased power losses, over heating due to skin effect as higher frequency current flows on cable periphery increasing cable resistance, pulsating torque due to negative phase sequence harmonics
Transformer, Switchgear, Power Cables	Over-heating, increased power consumption
Protective Relays	Mal-operation, nuisance tripping
Power Electronics	Mal-operation, failure
Power Capacitors	High currents & failure due to overload

The above malfunctions are not always felt immediately after the system is installed, but the effects may be felt in the long term and are difficult to distinguish from the natural ageing of equipment. Hence it is important to have some basic knowledge about harmonics and find solutions for the same.

Harmonic amplification is an undesired increase in the magnitude of harmonics beyond the level that is being generated in the system. This in turn amplifies the ill effects of the harmonics. This section briefs how the amplification happens in the network and solutions to avoid this amplification.

Power capacitors are added to the network for improving the power factor. The addition of capacitors results in reduction of system impedance. Capacitive impedance is inversely proportional to frequency (as shown in the figure 1).

$$\text{Capacitive impedance } X_c = \frac{1}{2\pi fc} \text{ -----> Eq 1}$$

Hence the capacitor offers lower impedance for high frequency (250 Hz, 350 Hz, 550 Hz and so on). This results in increase in the magnitude of harmonic currents. This can be practically seen by measuring harmonics at a particular location in the electrical network with and without power factor correction capacitors (APFC panels).

Following are the snapshots of harmonic measurement done at the main incomer, with and without capacitors.

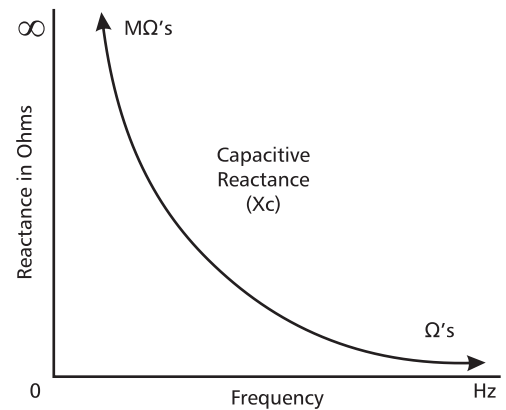
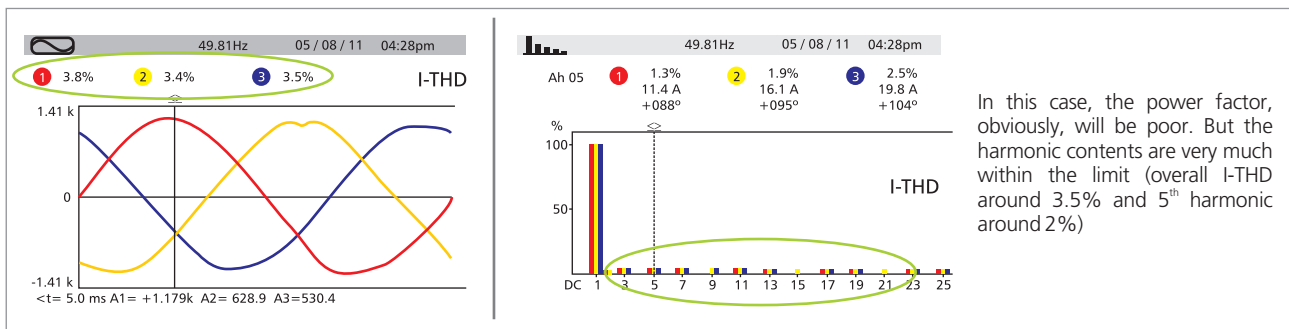

Figure 1

Figure 2: Measurement with APFC Panel OFF



In this case, the power factor, obviously, will be poor. But the harmonic contents are very much within the limit (overall I-THD around 3.5% and 5th harmonic around 2%)

Figure 3: Measurement with APFC Panel ON

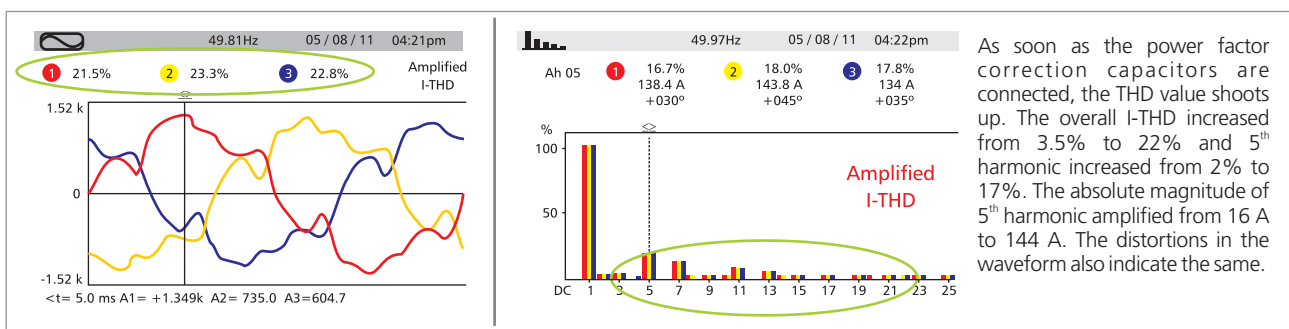

As soon as the power factor correction capacitors are connected, the THD value shoots up. The overall I-THD increased from 3.5% to 22% and 5th harmonic increased from 2% to 17%. The absolute magnitude of 5th harmonic amplified from 16 A to 144 A. The distortions in the waveform also indicate the same.

In the above equation (1), for the same set of harmonic frequencies, on adding more capacitors for PF improvement, the capacitive impedance (X_c) will drop further. Again this will result in amplification of the harmonics. If the power factor goes to leading, the amplification will be worse. The unnecessary amplification of harmonics damages power capacitors and over heats switchgear, cables and busbars.

The solutions to prevent harmonic amplification are:

- By connecting a series inductor, so as to form a detuned filter (series LC), the impedance increases, when the frequency increases (as $X_L = 2\pi fL$). The impedance will be high for high frequency harmonics and no amplification will happen. Hence, the THD (with reactor + capacitor) will be less than or equal to the earlier THD levels with no capacitors
- By strictly avoiding leading power factor, the excess addition of capacitors can be prevented and hence the amplification because of this can also be avoided. The optimum power factor of 0.97 to 0.99 should be maintained always

Many industries may not generate high harmonics. Sometimes harmonic resonance occurring between power capacitors and transformers causes very high magnification of harmonics. This causes increased rate of failures and over-heating of electrical equipments. This section briefs about the basics of harmonic resonance, a practical case study and solution to avoid resonance.

In a system with inductive (X_L) and capacitive (X_C) impedances, resonance can happen at one particular frequency (resonant frequency, F_R). At this point X_L is equal to X_C and the net impedance is very low. Hence, at resonance point, the magnitude of the current (with frequency F_R) will be maximum and only inherent resistance in the network would limit the current.

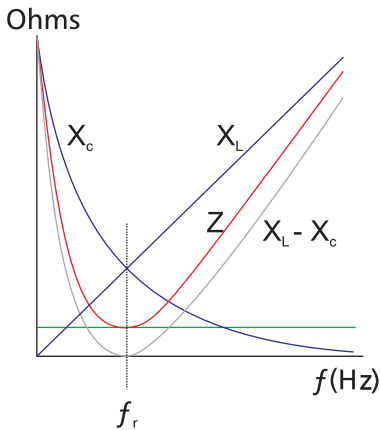

In practical network, the resonance is possible because of one of the following reasons:

- Parallel resonance within a given electrical system, involving internally generated harmonics (in the load) and resonance between local capacitors and the predominantly inductive supply (transformers)
- Series resonance involving external harmonics (in the supply system) and resonance between capacitors within electrical system
- Interactive resonance between different harmonics filters within a given electrical network

Typically, the inductance (L , of the transformer) in the system remains almost constant, but the capacitance (C) is varied (in steps) as per the requirement to maintain higher power factor. So, when the capacitance increases the resonant frequency (F_R) drops, as F_R is inversely proportional to square root of capacitance.

$$\text{Resonant frequency } F_R = \frac{1}{2\pi\sqrt{LC}}$$

The lower resonant frequency is dangerous, as it may match with any of the predominant harmonics and cause more damage. Let us see a practical case study of resonance happening between variable PFC capacitors (C) and transformer.

Consider an industry with 1000 kVA transformer of $\%Z = 5.67\%$ and 750 kVAr APFC panel. The resonant frequency can be calculated from the formula:

$$\text{Resonant frequency} = F_s \times \sqrt{\frac{\text{kVA}_{sc}}{\text{kVAr}}}$$

Where F_s is the System frequency = 50 Hz

$$\text{kVA}_{sc} \text{ is the short circuit power of the transformer} = \frac{\text{kVA}}{\%Z/100} = \frac{1000}{0.0567} = 17636\text{kVA}$$

kVAr is the power rating of the capacitor connected under the transformer for power factor correction.

Case 1: When 145 kVAr is Connected to the System,

$$\text{Resonant frequency} = 50 \times \sqrt{\frac{17636}{145}} = 550\text{Hz}$$

This frequency exactly matches with 11th harmonic (550 Hz) and results in resonance. Following is the harmonics measurement that depicts the 11th harmonic resonance, where it increases from less than 5% to 25%. This huge amplification will damage the capacitor and other equipments.

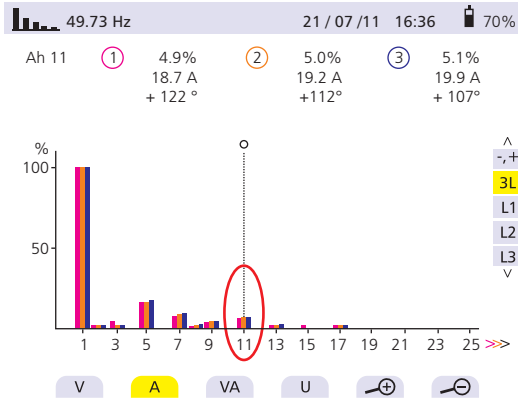

Figure 1: Measurement with APFC Panel OFF

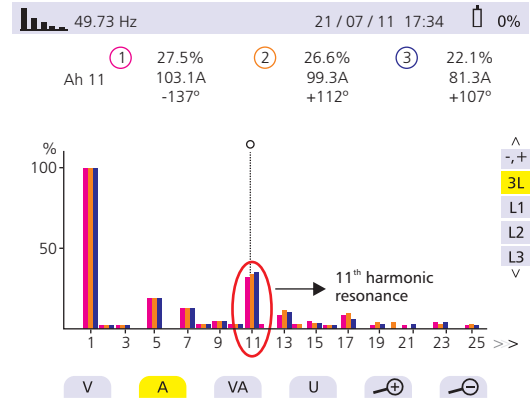

Figure 2: Measurement with APFC Panel ON

Case 2: When 250 kVAr of Capacitor is Switched on in the Same Industry,

$$\text{Resonant frequency} = 50 \times \sqrt{\frac{17636}{250}} = 420\text{Hz}$$

In this case, no resonance will happen; hence the amplification level will be less than the case 1. If harmonics study is carried at this particular moment, the system would reveal relatively lesser harmonics level (%I-THD)

Case 3: When 700 kVAr is Connected to the System,

$$\text{Resonant frequency} = 50 \times \sqrt{\frac{17636}{700}} = 250\text{Hz}$$

Once again, this frequency perfectly matches with 5th harmonic. Typically 5th harmonic is the least order harmonic with higher magnitude (6 pulse drives). Resonance at this harmonic order would result in even worse damage than the case 1.

From the above cases it is evident that any peculiar problem like frequent failure of capacitors, nuisance tripping of MCCBs, frequent blowing of fuses and over-heating of busbars is, may be because of harmonic resonance. Resonance or worst case THD may not be revealed at the moment of harmonic measurement or troubleshooting. Hence at times, finding the root cause of any such failures is very difficult.

Solution for harmonic resonance is to detune, by using a reactor in series with each capacitor. This detuned filter will forcefully create one resonant frequency, so that the combination offers higher impedance for high frequency harmonics. For example, installation of 7% reactor with each capacitor in APFC panel, will create tuning frequency at 189 Hz. Hence, resonance at harmonic frequencies (5th harmonics and above) can be avoided. Moreover, all the harmonics having frequency above 189 Hz (i.e., from 5th harmonics onwards) will lie in inductive region, where the impedance increases when the frequency increases ($X_L = 2\pi fL$). One important point to note is that all the capacitors in the industry must have similar series inductor; else the overall tuning frequency may not be at 189 Hz.

It's a known fact that harmonics cause over loading of power capacitors and consequently reduce the life of power capacitors. Normally lot of emphasis is given only to %THD for assessing the harmonics level while the frequency spectrum (5th, 7th, 11th, 13th and so on) of the harmonics are not given due importance.

The over-current (and hence the stress on the capacitors) will not only depend on the %THD value but also on the magnitude of individual harmonics, which can be clearly seen in the frequency spectrum. Following calculations prove the above statement.

Case 1:

Assumptions:

1. V_{THD} : 25%
2. Harmonic frequencies considered: 5th (250 Hz), 7th (350 Hz)
3. $V_5=20\%V_1$ and $V_7=15\%V_1$
4. All other harmonic frequencies are negligible
5. The capacitors are delta connected hence will not provide a path for the third harmonic to flow

Important Formulae:

$$X_c = \frac{1}{(2 \pi f C)}$$

where X_c is the capacitive reactance, f is the frequency, C is the capacitance $I_c = V_c / X_c$, where I_c is the capacitive current, V_c is the voltage across the capacitor and X_c is the capacitive reactance

$$V_{THD} = \sqrt{\sum (V_i^2) / V_1}, \text{ where } i=3 \text{ to } 99$$

Calculations:

Using the superposition theorem, we can calculate the current contribution of individual harmonic voltages.

$$I_5 = V_5 / X_{c5} = 0.2V_1 / [1/(2 \times \pi \times 5 \times f \times C)] = 0.2 \times 5 \times V_1 / X_{c1} = 1 \times V_1 / X_{c1} = I_1$$

Similarly,

$$I_7 = 1.05I_1$$

The total current I will be a vector sum of I_1 , I_5 and I_7

$$\text{Thus } I = \sqrt{(I_1^2 + I_5^2 + I_7^2)} = \sqrt{(1+1+1.1025 \times I_1^2)}$$

$$\text{Net current, } I = 1.8 I_1 \text{ -----> (1)}$$

Case 2:

Assumptions:

1. V_{THD} : 25%
2. Harmonic frequencies considered: 5th (250 Hz), 7th (350 Hz), 11th (550 Hz), 13th (650 Hz)
3. $V_5 = 18\%V_1$, $V_7 = 15\%V_1$, $V_{11} = 8\%V_1$ and $V_{13} = 4\%V_1$

Calculation:

$$I_5 = V_5 / X_{c5} = 0.18V_1 / [1/(2 \times \pi \times 5 \times f \times C)] = 0.18 \times 5 \times V_1 / X_{c1} = 0.9 \times V_1 / X_{c1} = 0.9I_1$$

Similarly,

$$I_7 = 1.05I_1, I_{11} = 0.88I_1 \text{ and } I_{13} = 0.52I_1$$

The total current I will be a vector sum of I_1 , I_5 , I_7 , I_{11} and I_{13}

$$\text{Thus } I = \sqrt{I_1^2 + I_5^2 + I_7^2 + I_{11}^2 + I_{13}^2} = \sqrt{(1+0.9^2+1.05^2+0.88^2+0.52^2)} \times I_1$$

$$\text{Net current, } I = 2 I_1 \text{ -----> (2)}$$

Thus, in the above two cases, even the THD value remains same (25%), the net rms current (ref. Eq 1 and Eq 2) value is different depending upon the spectral values.

Hence THD value and detailed information of the frequency spectrum are necessary to predict the capacitor over-current. Harmonics study is the best way to get the frequency spectrum details and hence the exact over current value can be calculated.

Current and voltage harmonics are often used interchangeably. At most places, only harmonics is quoted and whether the values pertain to current or voltage is not mentioned. The differentiation can be done on the basis of their origin.

Understanding Total Harmonic Distortion

The current and voltage harmonics in a system are often expressed as Total Harmonic Distortion (THD). The total harmonic distortion, or THD, of a quantity is a measurement of the harmonic distortion present and is the ratio of all harmonic components to the fundamental component. It is given by the formula as under:

$$THD_y = \frac{\sqrt{\sum_{h=2}^{\infty} Y_h^2}}{Y_1} \quad \text{Where, } Y_1 \text{ is the rms value of fundamental}$$

$$Y_h \text{ is the rms value of } h^{\text{th}} \text{ harmonic}$$

Hence, current THD is the ratio of the root-mean-square value of the harmonic currents to the fundamental current.

$$I_{THD} = \frac{\sqrt{\sum_{h=2}^{\infty} I_h^2}}{I_1}$$

Where do Current & Voltage Harmonics Originate?

Harmonics always originate as current harmonics and voltage harmonics are the results of current harmonics. Current harmonics originate because of the presence of non-linear loads like variable speed drives, inverters, UPS, television sets, PCs, semiconductor circuits, welding sets, arc furnaces in the system. They act as harmonic current sources. The resulting current waveform can be quite complex depending on the type of load and its interaction with other components of the system.

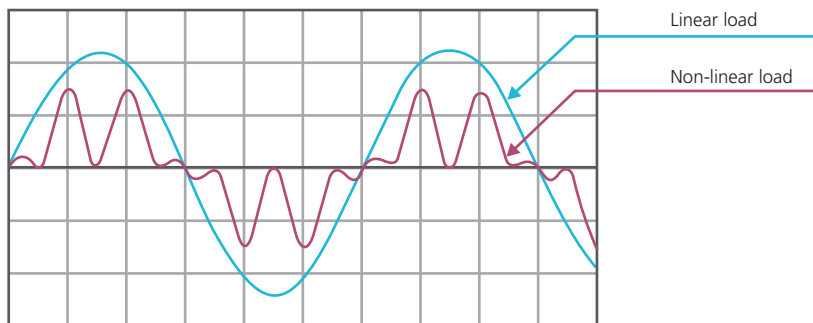
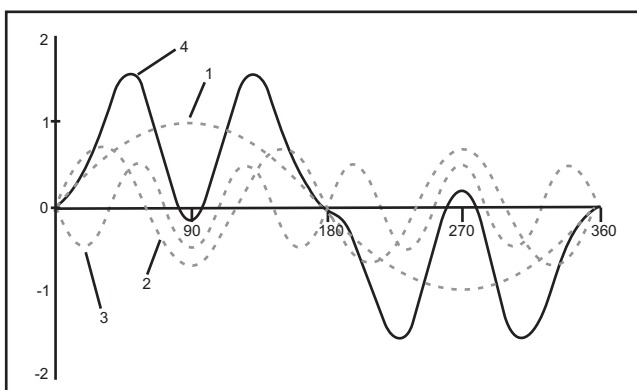

Fig 1: Linear & Non-Linear Loads

The distorted current waveforms can be represented as the sum of current waveform of fundamental frequency and of its multiples (harmonics):



$$f(t) = \sum_{h=1}^{\infty} (C_h \sin(h\omega_0 t + \phi_h))$$

Where,

C_h - Magnitude of nth order harmonics

ϕ_h - Phase angle of nth order harmonics

Fig 2: Current waveform as sum of fundamental frequency component and its multiples

Voltage harmonics do not originate directly from non-linear loads. The current harmonics (distorted waveform) flow through system impedance (source and line impedances) and cause harmonic voltage drop across the impedances. This will distort the supply voltage waveform. Thus voltage harmonics are generated. Long cable runs, high impedance transformers, etc. contribute to higher source impedance and hence, higher voltage harmonics.

A typical power system has the following impedances as indicated in the line diagram:

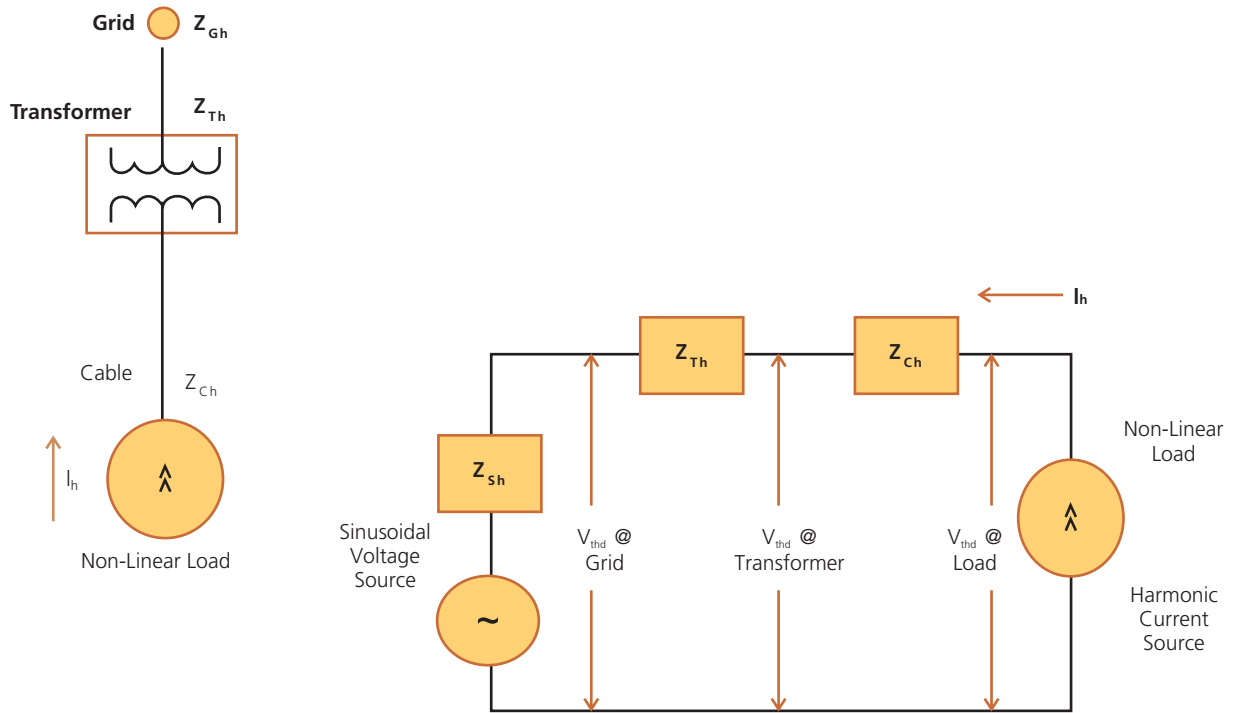

Fig 3: Impedance in a power system

In the above diagram,

$V_h = h^{\text{th}}$ harmonic voltage

$I_h = h^{\text{th}}$ harmonic current

$Z_h =$ Impedance at h^{th} harmonic

$V_{thd} =$ Voltage total harmonic distortion

At load, $V_h = I_h \times (Z_{Ch} + Z_{Th} + Z_{Gh})$

At transformer, $V_h = I_h \times (Z_{Th} + Z_{Gh})$

At grid, $V_h = I_h \times (Z_{gh})$

Usually, grid impedances are very low and hence, the harmonic voltage distortions are also low there. However, they may be unacceptably higher on the load side as they are subjected to full system impedance there. Hence, it becomes important where the harmonics measurements are done.

However, in case of DG sets, the source impedance is large resulting in high voltage harmonics despite small current harmonics. Thus, a clear distinction between current and voltage harmonics becomes important here.

An industry, say industry A, that has large non-linear loads will generate huge current harmonics in its system. A nearby industry, say industry B, connected to the same grid may not have non-linear loads, yet, it may be subjected to high voltage harmonics. These voltage harmonics are the result of high current harmonics of industry A and impedance of grid & transformer. Thus, industry B despite small current harmonics, has high voltage harmonics. However, if industry B goes for power factor correction, then, due to the presence of capacitors, current harmonics may also appear in the system, magnifying voltage harmonics further.

How do Current & Voltage Harmonics Affect the System?

Current harmonics increase the rms current flowing in the circuit and thereby, increase the power losses. Current harmonics affect the entire distribution all the way down to the loads. They may cause increased eddy current and hysteresis losses in motor and transformers resulting in over-heating, overloading in neutral conductors, nuisance tripping of circuit breakers, over-stressing of power factor correction capacitors, interference with communication etc. They can even lead to over-heating and saturation of reactors.

Voltage harmonics affect the entire system irrespective of the type of load. They affect sensitive equipment throughout the facility like those that work on zero-voltage crossing as they introduce voltage distortions.

Understanding IEEE 519 Guidelines

The purpose of harmonic limits in a system is to limit the harmonic injection from individual customers to the grid so that they do not cause unacceptable voltage distortion in the grid. IEEE 519 specifies the harmonic limits on Total Demand Distortion (TDD) and not Total Harmonic Distortion (THD). TDD represents the amount of harmonics with respect to the maximum load current over a considerable period of time (not the maximum demand current), whereas, THD represents the harmonics content with respect to the actual load current at the time of measurement.

It is important to note here that a small load current may have a high THD value but may not be significant threat to the system as the magnitude of harmonics is quite low. This is quite common during light load conditions.

TDD limits are based on the ratio of system's short circuit current to load current (I_{sc}/I_L). This is used to differentiate a system and its impact on voltage distortion of the entire power system. The short circuit capacity is a measure of the impedance of the system. Higher the system impedance, lower will be the short circuit capacity and vice versa.

The Guidelines IEEE 519-2014 at PCC Level are as under:

Current distortion limits for General Distribution systems (120V Through 69 kV)						
Maximum Harmonic Current Distortion in %I_L						
Individual Harmonic Order (Odd Harmonics)						
I_{sc}/I_L	$3 \leq h < 11$	$11 \leq h < 17$	$17 \leq h < 23$	$23 \leq h < 35$	$35 \leq h \leq 50$	TDD
<20	4.00%	2.00%	1.50%	0.60%	0.30%	5.00%
20-50	7.00%	3.50%	2.50%	1.00%	0.50%	8.00%
50-100	10.00%	4.50%	4.00%	1.50%	0.70%	12.00%
100-1000	12.00%	5.50%	5.00%	2.00%	1.00%	15.00%
>1000	15.00%	7.00%	6.00%	2.50%	1.40%	20.00%

where

I_{sc} = maximum short-circuit current at PCC [Can be calculated as $MVA/(\%Z \times V)$]

I_L = maximum demand load current (fundamental frequency component) at PCC

Systems with higher I_{sc}/I_L have smaller impedances and thus they contribute less in the overall voltage distortion of the power system to which they are connected. Thus, the TDD limits become less stringent for systems with higher I_{sc}/I_L values. In other words, higher the rating of transformer used for the same amount of load, higher will be the allowable current distortion limits.

Voltage distortion limits		
Bus Voltage at PCC	Individual Voltage Distortion	V_{THD}
$V \leq 1.0$ kV	5.00%	8.00%
1 kV $\leq V \leq 69$ kV	3.00%	5.00%
69 kV $\leq V \leq 161$ kV	1.50%	2.50%
> 161 kV	1.00%	1.50%

The limits on voltage are set at 8% for total harmonic distortion and 5% of fundamental for any single harmonic at PCC level. Harmonics levels above this may lead to erratic functioning of equipment. In critical applications like hospitals and airports, the limits are more stringent (less than 3% V_{THD}) as erroneous operation may have severe consequences. As discussed already, the harmonic voltage will be higher downstream in the system.

Solutions for Current & Voltage Harmonics

Current Harmonics (I_{THD})	Voltage Harmonics (V_{THD})	Recommended Solutions**
High	Low ($\leq 5\%$)	Detuned Harmonic Filter with (SHD / LTXL)480 V Capacitors and/or Active Harmonic Filter
High	High ($> 5\%$)	Detuned Harmonic Filter (High V-THD Withstand*) with 525V (SHD/LTXL Cyl) Capacitors and/or Active Harmonic Filter
Low	High ($> 5\%$)	Grid may be polluted with imported voltage harmonics. It may not be possible to reduce them at the load side. Check with utility to rectify. However, Power factor correction can still be achieved with Detuned Harmonic Filter (High V-THD Withstand*) along with 525V capacitors

**These are typical solutions. However the actual solution may vary depending up on the actual harmonic content in the system.

* For High V-THD applications, please contact E&A for customized solutions.

Triplen harmonics have frequencies in odd multiples of 3, i.e., 3rd harmonic (150 Hz), 9th harmonic (450 Hz), 15th harmonic (750 Hz) and so on. These harmonics have some peculiar characteristics, which make them very difficult to handle and mitigate. This section explains about the basics, sources, effects and mitigation techniques of triplen harmonics.

Sources of Triplen Harmonics

Triplen harmonics are usually generated by single phase non-linear loads that share a common neutral. Some of them are,

- SMPS in computers, televisions, etc.,
- CFL lamps
- Electronic dimmers and so on

These types of loads are common in IT parks, office, hospital and other commercial buildings. Following are the typical current harmonic spectra of SMPS and CFL lamps, where third harmonic is predominantly high.

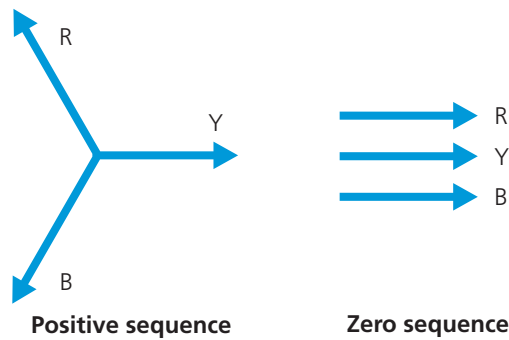

Neutral current is the vector sum of all the three phase (120° phase displaced) and the sum is zero, if the loads are balanced in all the three phase. But the presence of triplen harmonics will result in the flow of neutral current, even if the loads are balanced. This phenomenon is explained below:

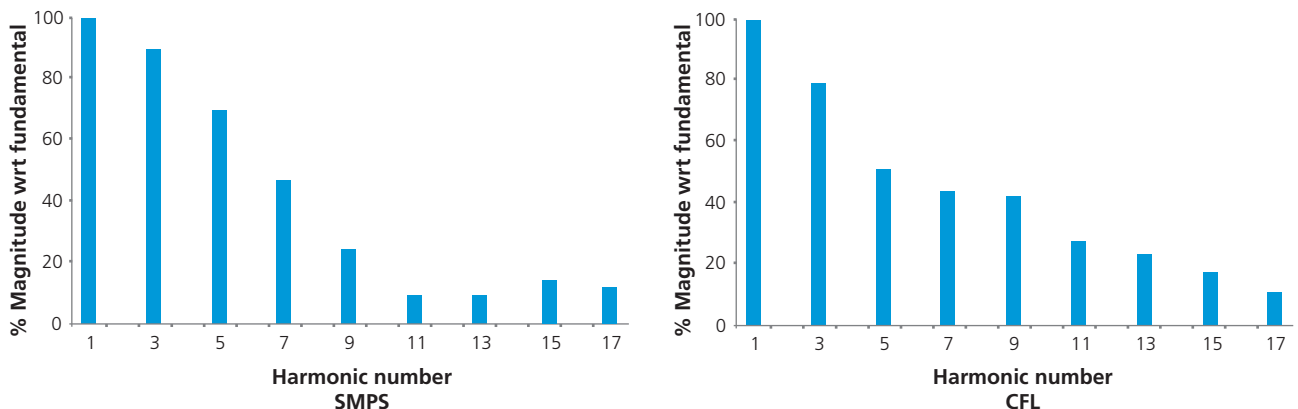

All the triplen harmonics are zero sequence in nature and they are exactly in-phase in all the three phases, whereas the fundamental component (50 Hz), has positive phase sequence, displaced by 120° between the three phases.

The accumulated neutral current, because of the additive triplen current, can go up to 200% of the phase current.

Three Phase System

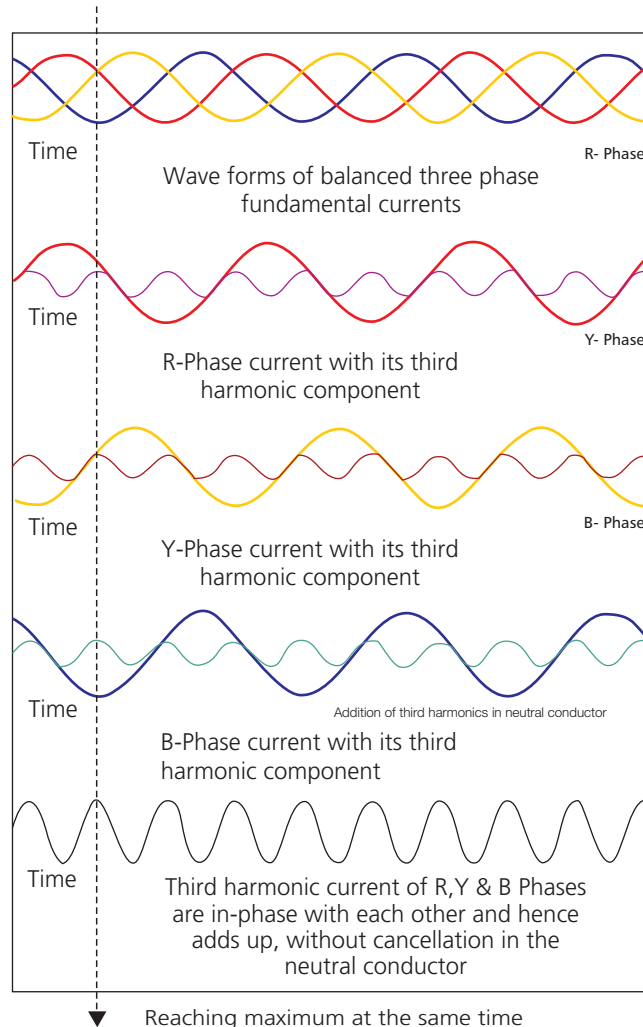

III Effects of Triplen Harmonics

- The harmonics accumulate in neutral and cause hot neutral or neutral burning due to neutral over-loading. Thus, we need to use a higher sized cable for neutral
- Distribution transformer over heating
- Busbars and cable overheating due to skin effect
- Eddy current losses (as eddy current is proportional to square of the frequency)
- Reduced life of electrical equipments like transformers, power capacitors, switchgear, etc.

Triplen Harmonic Mitigation

Most commonly used passive filter for triplen harmonics is 14% detuned filter. This filter has the tuning frequency of 133 Hz, which is below the 3rd harmonic (150 Hz). This filter is very effective in averting the harmonic amplification of 3rd harmonics & above and thereby protecting power capacitors and other equipments. But detuned filter does not eliminate the harmonics completely. In order to achieve that, active harmonic filters with three-phase four-wire configuration should be used.

Benefits of Harmonics Mitigation

- Reduction in operating expenses**
 Harmonic mitigation contributes to reduced power losses in transformers, cables, switchgear. Harmonic mitigation helps in reducing the energy losses
- Reduction in capital expenditure**
 Harmonic mitigation reduces the r.m.s. value of the current and it eliminates the need to oversize transformers and hence switchgear, cables and busbars
- Improved business performance**
 Harmonics are responsible for increased line currents, resulting in additional power losses and increased temperature in transformers, cables, motors, capacitors. The consequence may be the unwanted tripping of circuit breakers or protection relays. This might cause significant financial losses linked to a process interruption

Solutions for Harmonic Mitigation

For any electrical system, which is expected to be harmonics rich, it is recommended to study the harmonics level, analyze and then a proper solution should be employed.

The different solutions employed are as follows:

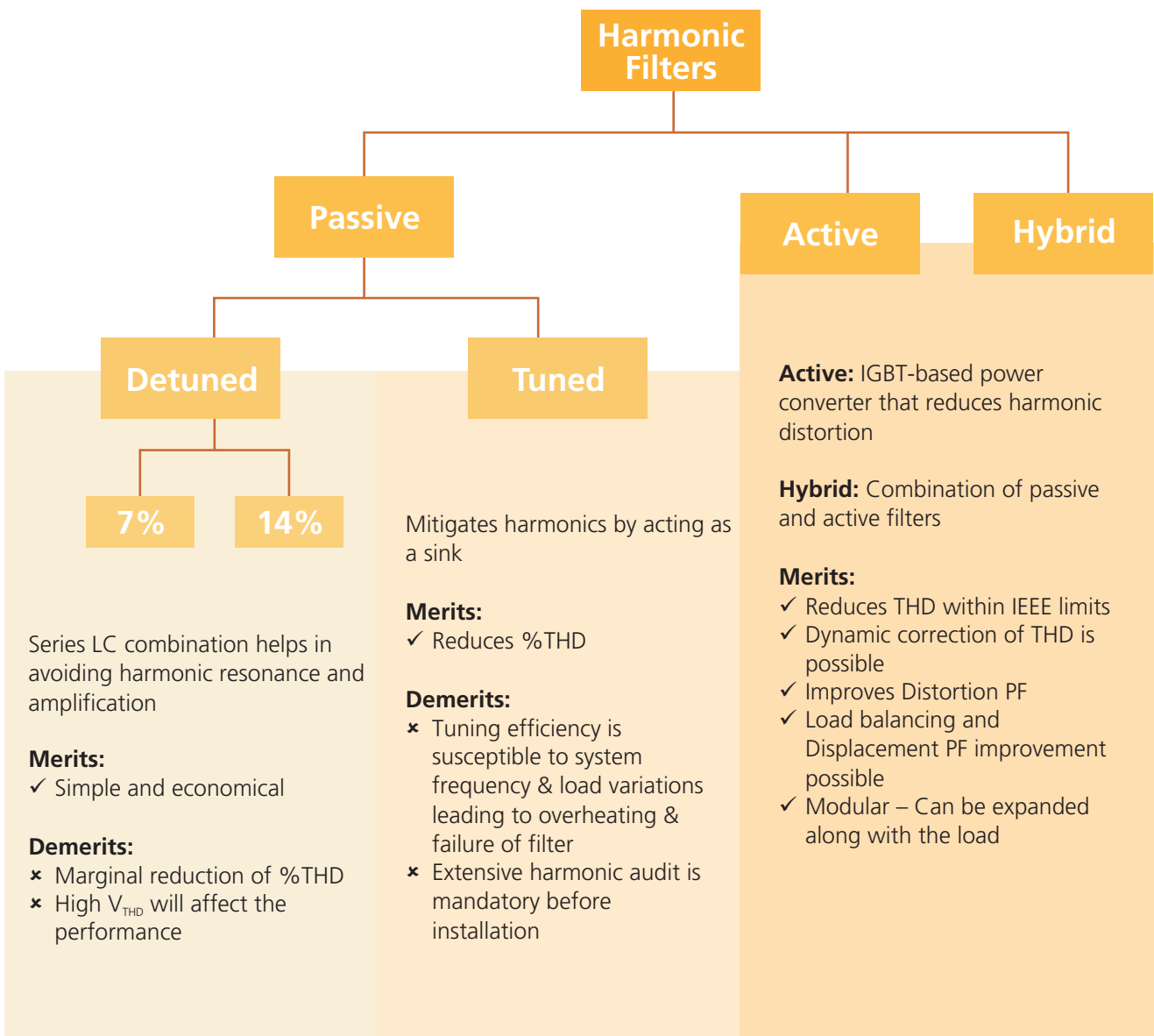

Detuned Filters are a combination of series inductors and power factor correction capacitors that are meant to:

1. Prevent resonance
2. Prevent harmonic amplification
3. Protect power factor correction capacitors from overload

Typically a detuned filter has a series connected capacitor and reactor. The capacitor terminal voltage varies with respect to the tuning factor (%p) of the reactor. Tuning factor (%p) is the ratio of inductive impedance to the capacitive impedance (X_L/X_C). Common tuning factors of detuned filters are 7% and 14%.

Every series LC combination behaves capacitive below its tuning frequency [$f_{res} = 1/(2\pi\sqrt{LC})$] and inductive above. The inductive element of the detuned filter is selected such that the tuning frequency of the filter is significantly lower than the lowest order harmonic frequency present in the system. The filter is thus 'detuned'. The ratio of inductive reactance (X_L) and capacitive reactance (X_C) is known as the tuning factor.

A tuning factor of 7% implies $X_L/X_C = 0.07$.

The tuning frequency using tuning factor can be calculated as:

$$f_t = \frac{f_s}{\sqrt{p/100}}$$

Where,

f_s = Supply Frequency = 50 Hz

For tuning factor of 7%, $f_t = 189$ Hz.

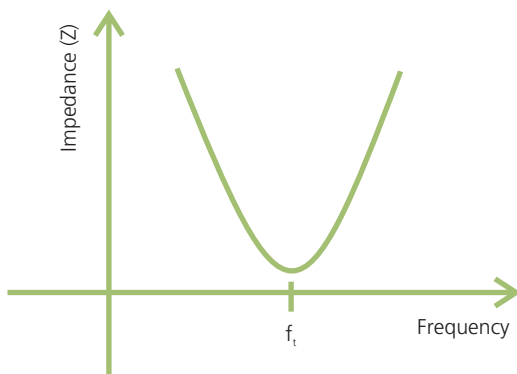

As can be seen from the above graph, for all frequencies above the tuning frequency (f_t), the combination will provide increasing impedance. The combination will not provide a low impedance path for harmonics that the capacitor did earlier, thus preventing harmonic amplification. Further as the tuning frequency of the combination is lower than the lowest order harmonic in the system, there is no question of resonance. At 50 Hz the combination behaves capacitive and power factor correction is achieved.

The voltage that appears across the terminals of a capacitor increases the moment you connect an inductor in series with it. This can be illustrated by the below phasor:

V_s : System Voltage; V_c : Voltage across the capacitor; V_L : Voltage across the inductor; I : current.

As can be seen $V_c > V_s$ by an amount V_L . Thus if reactors are to be added to an existing APFC panel, the capacitors will have to be replaced with those capable of withstanding higher voltages. More over, the output of the capacitors will have to compensate for the reactive power that will be consumed by the reactor.

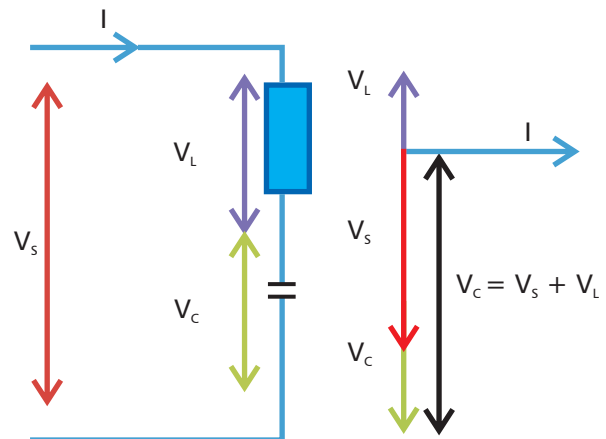

Secondly reactors are a major source of heat. The existing panel may not have sufficient space or cooling arrangement to handle the heat generated by the newly installed reactors. For these reasons, it is not advisable to add detuned reactors to existing APFC panels.

Hence, it is difficult to solve harmonics related problems, once the power factor correcting capacitors are installed. It is thus important to incorporate harmonic mitigation techniques in the system design stage itself.

Selection of Capacitor - Reactor Combination for Detuned Harmonics Filters

Typically a detuned filter has a series connected capacitor and reactor. The capacitor terminal voltage varies with respect to the tuning factor (%p) of the reactor. Tuning factor (%p) is the ratio of inductive impedance to the capacitive impedance (X_L / X_C). Common tuning factors of detuned filters are 7% and 14%.

The voltage that appears across the terminals of a capacitor increases the moment an inductor is connected in series.

The actual amount of voltage increase can be calculated using the following formula:

$$V_c = \frac{V_s}{\left(1 - \frac{\%p}{100}\right)}$$

- For example, the capacitor terminal voltage with 7% detuned reactor shall be calculated using the above formula:

$$V_c = \frac{440}{\left(1 - \frac{7}{100}\right)} \quad V_c = 473 \text{ V}$$

Hence the rated voltage of the capacitor should be selected as 480 V when used along with 7% reactor. Sometimes, the voltage variations, as per the electricity board voltage limits, may cause the supply voltage to exceed 480 V. Also, due to harmonics, both peak and rms voltage may go beyond 480 V. In such cases, a 525 V capacitor should be used along with 7% detuned reactor. Selection for both 480 V and 525 V capacitor with 7% reactor is given in the table.

- When 14% reactor is used along with the capacitor, the capacitor terminal voltage,

$$V_c = \frac{440}{\left(1 - \frac{14}{100}\right)} \quad V_c = 512 \text{ V}$$

Here the capacitor should be rated for 525 V when used along with 14% reactor.

Selection of capacitors for detuned harmonic filter application

Step Size & Reactor rating (440 V)	With 7% detuned reactor			With 14% detuned reactor	
	Capacitor Series	Capacitor (480 V)	Capacitor (525 V)	Capacitor Series	Capacitor (525 V)
1 kVAr	LTCCF,LTCCR	1.2 kVAr	1.3 kVAr	LTCCF,LTCCR	1.3 kVAr
2 kVAr	LTCCF,LTCCR	2.2 kVAr	2.6 kVAr	LTCCF,LTCCR	2.6 kVAr
3 kVAr	LTCCF,LTCCR	3.3 kVAr	3.9 kVAr	LTCCF,LTCCR	3.9 kVAr
4 kVAr	LTCCF	4.4 kVAr	5.3 kVAr	LTCCF	5.3 kVAr
	LTCCR		5 kVAr	LTCCR	5 kVAr
5 kVAr	LTCCF,LTCCCH,LTCCR,LTBCH,LTBCP	5.5 kVAr	6.6 kVAr	LTCCF,LTCCCH,LTCCR,LTBCH,LTBCP	6.6 kVAr
	LTCCN,LTCCU,LTBCU	7.5 kVAr	7.5 kVAr	LTCCN,LTCCU,LTBCU	7.5 kVAr
10 kVAr	LTCCD,LTCCCH,LTCCR,LTBCD,LTBCH,LTBCP	11.1 kVAr	13.2 kVAr	LTCCD,LTCCCH,LTCCR,LTBCD,LTBCH,LTBCP	13.2 kVAr
	LTCCN,LTCCU,LTBCU	12.5kVAr	12.5 kVAr	LTCCN,LTCCU,LTBCU	12.5 kVAr
12.5 kVAr	LTCCN,LTCCR,LTCCU,LTBCH,LTBCU	15 kVAr	15 kVAr	LTCCN,LTCCR,LTCCU,LTBCH,LTBCU	15 kVAr
	LTCCD,LTCCCH,LTBCD,LTBCP	13.8 kVAr	16.6 kVAr	LTCCD,LTCCCH,LTBCD,LTBCP	16.6 kVAr
15 kVAr	LTCCN,LTCCR,LTCCU,LTBCH,LTBCU	20 kVAr	20 kVAr	LTCCD,LTCCN,LTCCCH,LTCCR,LTCCU,LTBCD,LTBCH,LTBCP,LTBCU	20 kVAr
	LTCCD,LTCCCH,LTBCD,LTBCP	16.6 kVAr			
20 kVAr	LTCCN,LTCCR,LTBCH,LTBCU	25 kVAr	25 kVAr	LTCCN,LTCCR,LTBCH,LTBCU	25 kVAr
	LTCCD,LTCCCH,LTBCD,LTBCP	22.1 kVAr	26.5 kVAr	LTCCD,LTCCCH,LTBCD,LTBCP	26.5 kVAr
	LTCCU,	7.5 + 15 kVAr	2 x 12.5 kVAr	LTCCU	2x12.5 kVAr
25 kVAr	LTCCD,LTCCCH,LTCCR,LTBCD,LTBCH,LTBCP	27.7 kVAr	33.1 kVAr	LTCCD,LTCCN,LTCCCH,LTCCR,LTBCD,LTBCH,LTBCP,LTBCU	30 kVAr
	LTBCU	30 kVAr	33.1 kVAr		
	LTCCN		25 + 8.33 kVAr		
	LTCCU	12.5 + 15 kVAr	15 + 20 kVAr	LTCCU	(10+20) kVAr
50 kVAr	LTCCD,LTCCCH,LTCCR,LTBCD,LTBCH,LTBCP	2 x 27.7 kVAr	2 x 33.1 kVAr	LTCCD,LTCCN,LTCCCH,LTCCR,LTBCD,LTBCH,LTBCP,LTBCU	2 x 30 kVAr
	LTBCU	2 x 30 kVAr	2 x 33.1 kVAr		
	LTCCN		2 x (25 + 8.33) kVAr		
	LTCCU	2 x (12.5 + 15) kVAr	2 x (15 + 20) kVAr	LTCCU	2 x (10+20) kVAr
100 kVAr	LTCCD,LTCCCH,LTCCR,LTBCD,LTBCH,LTBCP	4 x 27.7 kVAr	4 x 33.1 kVAr	LTCCD,LTCCN,LTCCCH,LTCCR,LTBCD,LTBCH,LTBCP,LTBCU	
	LTBCU	4 x 30 kVAr	4 x 33.1 kVAr		
	LTCCN		4 x (25 + 8.33) kVAr		
	LTCCU	4 x (12.5 + 15) kVAr	4 x (15 + 20) kVAr	LTCCU	4 x (10+20) kVAr

* kVAr selection is based on minimum size required and higher standard rating available

Electrical networks often contain significant levels of harmonic distortion, which has led the large majority of manufacturers of automatic capacitor banks to unanimously include detuned filter units in their offerings. In this section, we will try to explain the impact of different detuned filters and the consequences of a poor choice, as well as the recommendation for avoiding these possible risks.

The Importance of Tuning Frequency in Capacitor Banks

There is no such unanimity in the choice of the tuning frequency of the detuned filter offered as standard.

In case the network has predominant 3rd order harmonics (150 Hz in 50 Hz networks), the use of detuned filters tuned at 134 Hz is more common (over voltage factor of $p = 14\%$).

However, a large majority of installations require capacitor bank fitted with detuned filters appropriate for 5th order harmonics (250 Hz in 50 Hz networks) or higher, which are normally produced by the more usual harmonic current sources, such as, drives, AC/DC rectifiers, induction ovens, etc. In such cases, there are two options available, that corresponding to an over voltage factor of $p = 7\%$ (tuning frequency of 189 Hz in 50 Hz networks) and $p = 5.67\%$ (tuning frequency of 210 Hz in 50 Hz networks).

It may seem from the above that the choice of a value of $p = 7\%$ or $p = 5.67\%$ might be indifferent and that both should give the same result when they are connected to the electrical network, but this is not strictly true.

Detuned Filters and Their Effect on Installations

To follow the arguments of this, we will briefly go through the operating principle of detuned filters.

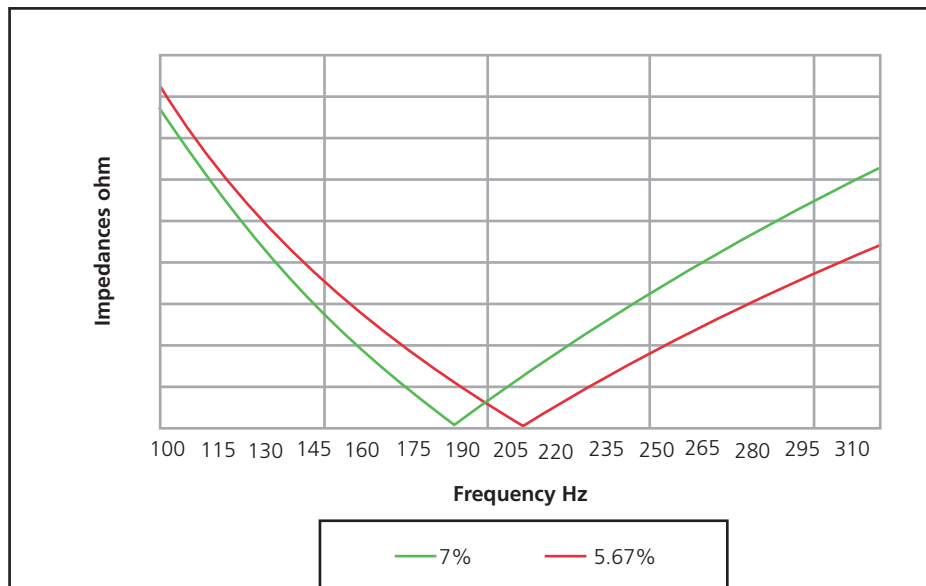

Fig. 1 Impedance-frequency graph of a detuned filter with $p = 7\%$ (189 Hz) and $p = 5.67\%$ (210 Hz)

Observing the impedance-frequency graph at rated current of a standard reactor-capacitor unit with $p = 7\%$ (green line in Fig. 1), we see that it offers least impedance at 189 Hz, whereas that corresponding to $p = 5.67\%$ (red line in Fig. 1) offers the least impedance at 210 Hz. In both cases, the impedance gradually increases on either side of it. The impedance is capacitive at frequencies under 189 Hz for 7% and 210 Hz for 5.67% respectively, and inductive at higher frequencies. It is this inductive character with harmonic frequencies of the 5th order or higher that prevents the possibility of a resonance phenomenon being produced at any of those frequencies. However, another key parameter for the correct operation of the detuned filter is the value of impedance at the different harmonic frequencies. Therefore, at said impedance-frequency in Fig. 1 the impedance difference of each tuning can clearly be seen at a harmonic frequency of 250 Hz.

What is The Main consequence of difference in Impedance Difference Shown By Both Tunings?

For $p = 5.67\%$, the value of the impedance is around half of the value for $p = 7\%$. Hence its ability to filter of 5th Harmonic and above is only half that of a 7% detuned filter.

The result will be that the absorption of harmonic currents by the capacitor will be higher for $p = 5.67\%$ than for $p = 7\%$ as it is providing less impedance to the harmonic frequency.

Other Effects on The Filtering Tuning

One basic point is the fact that if, to start with, a reactor with $p = 5.67\%$ is going to have a larger harmonic current consumption, then the reactor and the associated capacitor, must be designed to withstand the overload to which they are to be subjected on the level of intensity and temperature. However, in the particular case of a similarly-designed reactor with $p = 7\%$, the result is a smaller and lighter reactor, and a lower cost.

In short, in case of reactor with $p=5.67\%$, there is a risk that the capacitor bank might have to withstand higher levels of harmonic overloading, which would inevitably cause faster wear than in case of a capacitor with filter of $p = 7\%$.

The other essential point to be considered, which is the most important, is the influence of the capacitor capacity in tuning the reactor-capacitor series group according to the formula for tuning frequency:

$$f_{\text{res}} = \frac{1}{2\pi\sqrt{LC}}$$

A decrease in the capacitor capacity will result in an increase in the unit's resonance frequency. Capacitors are elements that lose capacity with time either due to their conditions of use (voltage, temperature, connection operation rate, etc.), or due to the natural deterioration of the polypropylene of their dielectrics. A same loss of capacity in a $p = 5.67\%$ filter and in one of $p = 7\%$, means that the first will come much closer to the 5th order frequency than the second, and the closer it comes, the greater harmonic current absorption it will present, the greater overloading it will suffer, leading to greater deterioration.

In other words, the safety margin given with this loss of capacity is considerably higher in a filter with $p = 7\%$

Conclusions for The Correct Choice of A Reactor

The conclusion in this case is clear, and is the unequivocal recommendation of the use of filters with $p = 7\%$ instead of $p = 5.67\%$ in all installations where they have to be applied due to the level of harmonic distortion.

The purpose of this recommendation is none other than to reduce the obvious risk that a loss of capacitor capacity could cause as a result of overcurrent in the capacitor bank much earlier. Thus, 7% detuned reactors allow a longer reaction time through pertinent maintenance actions and the application of corrective measures before the damage is definitive and, therefore, avert worse economic conditions.

An industry whose load includes a high proportion of non-linear load (harmonic generating loads), with poor power factor, requires capacitor with de-tuned filter. This performs the function of power factor improvement while preventing harmonic amplification.

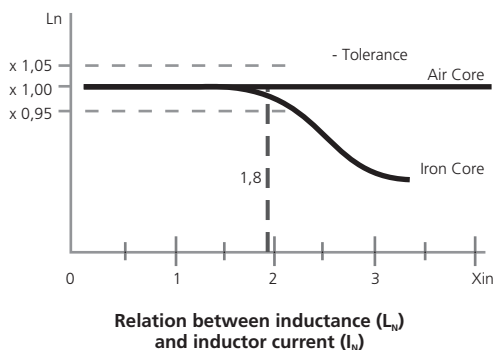

Normally, the inductance of the series reactor (of de-tuned filter) connected is chosen such that the tuning frequency of the de-tuned filter is 10% below the lowest harmonic frequency with considerable current/voltage amplitude. Therefore, resonance does not happen in the system and reactor offers high impedance for higher frequency harmonics.

Normally, 7% detuned reactors are designed considering typical industrial loads such as drives that have the following harmonic voltages: $V_3 = 0.5\% V_N$, $V_5 = 6\% V_N$, $V_7 = 5\% V_N$ and so on. However, if the individual harmonic voltages increase, the following phenomenon happens:

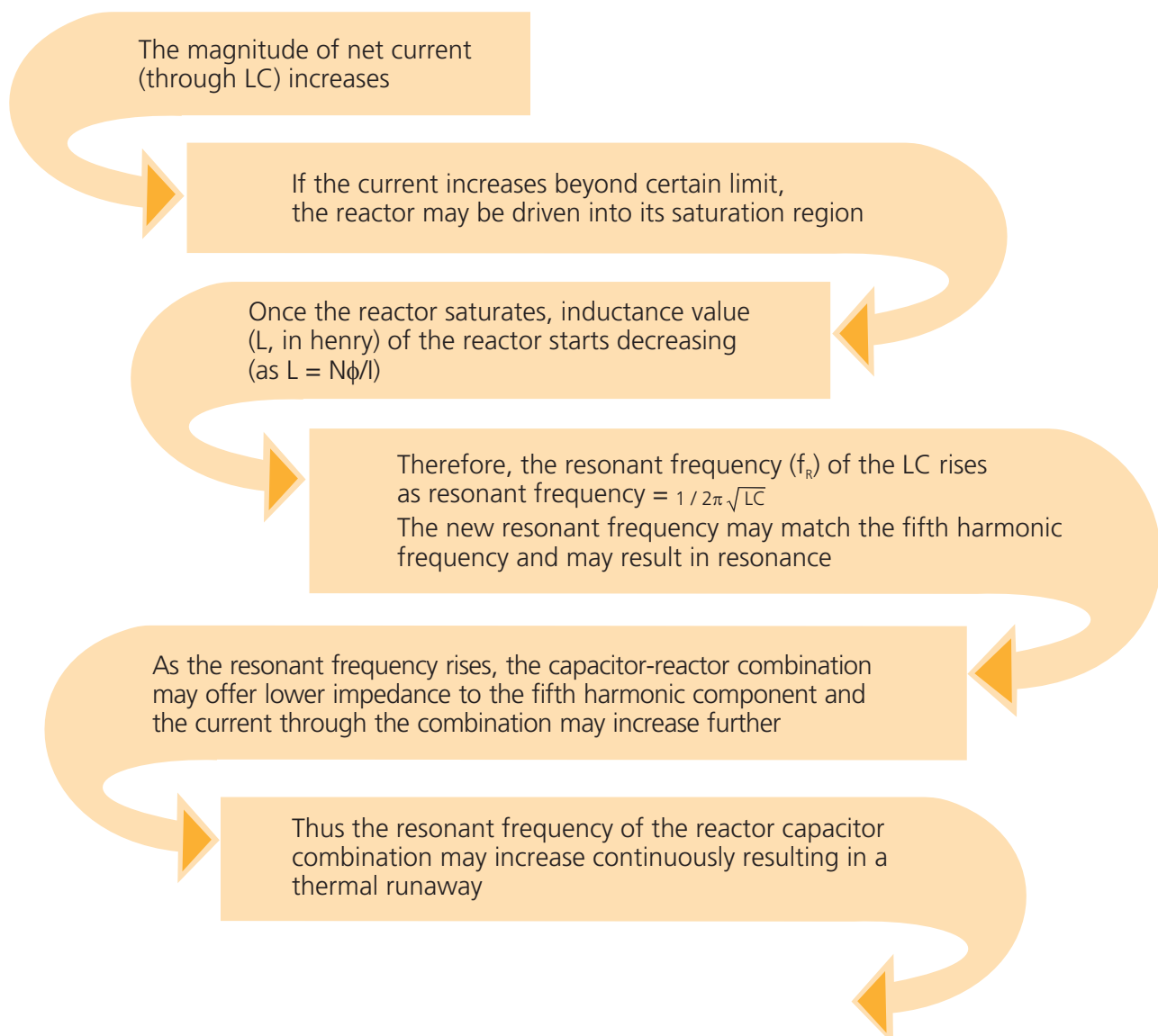

Normally, reactors are designed with predefined linearity. A reactor having a higher linearity does not saturate for higher harmonic currents and prevents the system from a thermal run away as described above.

The quality factor or Q-Factor is a dimensionless parameter that characterizes a resonator's bandwidth relative to its center frequency. It also describes the damping nature of a resonant circuit. Higher Q indicates a lower rate of energy loss relative to the stored energy of the oscillator; i.e., the oscillations die out more slowly. For example, a pendulum suspended from a high-quality bearing, oscillating in air, has a high Q, while a pendulum immersed in oil has a low one. Oscillators with high quality factors have low damping making them ring longer.

Theoretically, an inductor would have pure inductance only, whereas in reality they have some resistance. This resistance causes energy loss and acts as performance limiting factors for the inductor. Quality Factor helps in defining that performance of the inductor. The Q-Factor is the ratio of Inductive impedance to DC Resistance of detuned reactor.

$$Q\text{-Factor} = \frac{2\pi fL}{R}$$

Where,

f = Frequency; L = Inductance; R = Resistance

Thus, we can calculate the Q-Factor, just by knowing the power factor of the circuit.

$$Q\text{-Factor} = \frac{|\sin \phi|}{|\cos \phi|} = \frac{\sqrt{1-\text{PF}^2}}{\text{PF}} = \sqrt{\frac{1}{\text{PF}^2} - 1}$$

or just the tangent of the phase angle

$$Q \text{ factor} = |\tan \phi|$$

Effects of Q-factor on filter performance:

1. Losses:

Reactor with high Q-factor has lower power losses. Higher Q-factor implies lower DC resistance value which results in lower i^2R losses (conductor loss). It can also be explained by below formula:

$$\text{Power Loss} = \frac{\text{Total Power (kVA)}}{Q \text{ factor}}$$

Let us compare the performance of two detuned reactors with different Q-factors based on tested values:

Detuned reactor - 50 kVAr - 7% Tuning factor		
	1	2
L (mH)	0.92	0.93
DC Resistance (mΩ)	8.97	5.01
Q-factor (a)	32.2	58.3
kVA of reactor (b) ($V_r \cdot I_r$) + ($V_y \cdot I_y$) + ($V_b \cdot I_b$) (V: Voltage drop across the reactor, I: Rated current)	3845	3726
Ohmic power Losses (Watts) (b/a)	119.3	63.9
Difference (Watts)	55.4	

Thus, by choosing the detuned reactor with high Q-factor we can minimise the power loss (conductor loss). The reduction in reactor loss can be as high as 1.5 W/kVAr. Consequently, heat generation (temperature rise) in Power Factor correction panels will also come down.

2. Impedance offered by reactors:

A detuned reactor with higher Q-factor has sharper impedance curve. Hence it offers more impedance to higher harmonic frequencies.

Let us study the same based on tested values:

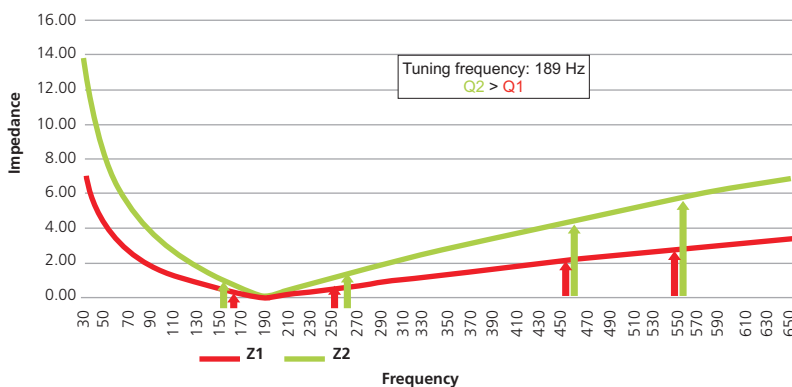

50 kVAr Capacitor - 7% Detuned reactor feeder		
	Z1	Z2
Reactor Voltage	440	
Reactor kVAr	50	50
Q-factor	32.2	58.3

As can be seen in the graph, reactor with higher Q-factor offers almost double impedance than the reactor with lower Q-factor for higher order harmonics. All other parameters of both the reactors like the inductance, linearity, etc are same, except the Q-factor. The higher impedance results in better reduction of harmonic amplification & resonance

How to achieve a high Q-factor?

To achieve good Quality factor, the detuned reactor should have minimum DC resistance as possible.

$$\text{Resistance} = \frac{\rho l}{A}$$

Where, ρ = Resistivity, l = Length, A = Area of cross-section

1. Resistance is directly proportional to resistivity. Conductor with lower resistivity (copper coil) can be chosen for winding of detuned reactors to get low DC resistance, thereby high Q-factor.
2. For a relatively higher resistivity materials like Aluminium, the cross-sectional area of the windings to be increased to decrease the effective resistance.

In this study, we have seen the Q-factor of two 50 kVAr 7% reactors one with Q-factor of 32 and other with Q-factor of 58. Practically, Q-factor as high as 58 is easily achievable (refer the above table). But considering other practical factors, any Q-factor value above 35 is preferable.

Conclusion:

Choosing the detuned reactors with good Q-factor (Quality factor) can help to control harmonic amplification even more effectively. In addition to this, reactors with good linearity limit and proper thermal design of panels will help in bringing the best out of the detuned reactors. While selecting detuned reactors, along with other specification / parameters like Linearity, Power Loss, Insulation class, etc., it is understood from this section that Q-factor should also be given equal importance.

The increasing use of modern power electronic apparatus (drives, uninterruptible power supplies, etc) produces nonlinear current and thus influences and loads the network with harmonics (line pollution).

The capacitance of the power capacitor forms a resonant circuit in conjunction with the feeding transformer. Experience shows that the self-resonant frequency of this circuit is typically between 250 and 500 Hz, i.e. in the region of the 5th and 7th harmonics. Such a resonance can lead to the following undesirable effects:

- Overloading of capacitors
- Overloading of transformers and transmission equipment
- Interference with metering and control systems, computers and electrical gear
- Resonance elevation, i.e. amplification of harmonics
- Voltage distortion

These resonance phenomena can be avoided by connecting capacitors in series with filter reactors in the PFC system. These so called "detuned" PFC systems are scaled in a way that the self-resonant frequency is below the lowest line harmonic and the detuned PFC system is purely inductive as seen by harmonics above this frequency. For the base line frequency (50 or 60 Hz usually), the detuned system on the other hand acts purely capacitive, thus correcting the reactive power.

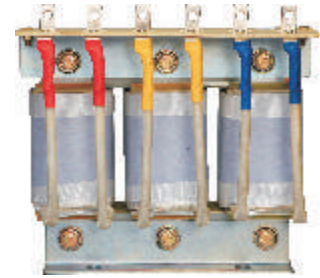

Features

- Copper and Aluminium wound reactors
- Very low operating losses
- High linearity - 1.8 times the rated current
- Low noise
- Auto-thermal cutoff**

Reactor Tuning Factor	Tuning Frequency	Application (Harmonic Orders)	Typical Loads
7%	189 Hz	5 th harmonic (250 Hz) and above	6 pulse drives (AC / DC), 3 phase UPS, frequency converters
14%	133 Hz	3 rd harmonic (150 Hz) and above	Single phase UPS, CFL lamps, SMPS, dimmers

Technical Details (Copper and Aluminium)

Tuning Factor	7%	14%
Tuning Frequency	189 Hz	134 Hz
Winding	Copper / Aluminium	
Standards	IEC 60076-6:2007, IS 5553	
Rated Voltage (V)	440 V	
Rated Frequency (F)	50 Hz	
Max Permissible Operating Voltage	1.05 Un Continuously, 1.1 Un for 8 hours	
Max Permissible Operating Current (Irms)	1.3 In Continuously	
Max Permissible Saturation Current (Linearity)	180% x In	
Duty Cycle	100%	
Ambient Temperature	40 °C	
Insulation Class	Class H	
Protection	Thermal Switch (NC contact)**	
Power Losses (W)	Copper Wound	Aluminium Wound
	~ 4 W/kVAr (upto 10 kVAr)	~ 5 W/kVAr (upto 10 kVAr)
	~ 3 W/kVAr (above 10 kVAr)	~ 4 W/kVAr (above 10 kVAr)
Q-Factor	>35	
Harmonics Limit	V3 = 0.5% VR (duty cycle = 100%)	
	V5 = 6.0% VR (duty cycle = 100%)	
	V7 = 5.0% VR (duty cycle = 100%)	
	V11 = 3.5% VR (duty cycle = 100%)	
	V13 = 3.0% VR (duty cycle = 100%)	

** To be connected in series with contactor coil. When temperature exceeds 120° C, NC opens and disconnects the reactor from the circuit.

7% & 14% Detuned Reactor (Copper) 440 V - Overall Dimensions

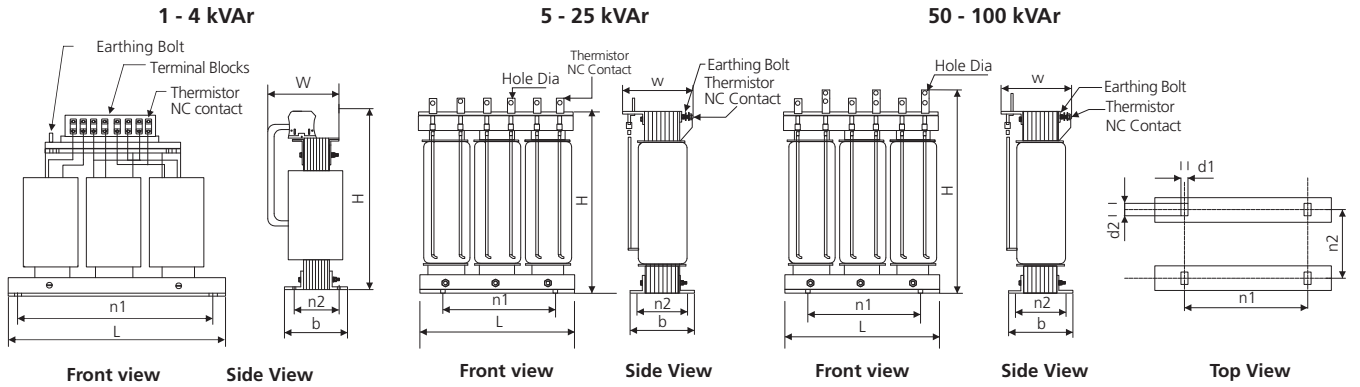

Tuning factor	kVAr	Cat. No.	Rated Current (A)	I rms (A)	Inductance (mH)	Terminal Hole	All Dimensions in mm								Weight (kg)
							L	H	W	n1	n2	b	d1	d2	
7%	1	LTFR0701B2	1.3	1.69	46.5	6	170	153±5	85±5	155	55±5	71±5	6	12	3
7%	2	LTFR0702B2	2.6	3.38	23.2	6	170	153±5	90±5	155	63±5	76±5	6	12	3.6
7%	3	LTFR0703B2	3.9	5.07	15.5	6	170	153±5	105±5	155	70±5	86±5	6	12	4.5
7%	4	LTFR0704B2	5.3	6.89	11.63	6	170	153±5	115±5	155	85±5	101±5	6	12	5.5
7%	5	LTFR0705B2	6.6	8.58	9.28	6	215	175	135±5	120	76±3	106±3	12	20	8
7%	10	LTFR0710B2	13.2	17.16	4.64	6	215	175	150±5	120	91±3	121±3	12	20	11.5
7%	12.5	LTFR0712B2	16.5	21.45	3.72	6	215	175	155±5	120	96±3	126±3	12	20	12.5
7%	15	LTFR0715B2	19.8	25.74	3.09	6	215	175	155±5	120	96±3	126±3	12	20	12.5
7%	20	LTFR0720B2	26.4	34.32	2.32	6	240	220	150±5	120	86±3	116±3	12	20	16
7%	25	LTFR0725B2	33	42.9	1.85	6	240	220	155±5	120	91±3	121±3	12	20	17
7%	50	LTFR0750B2	66	85.8	0.927	8	300	280±5	185±5	150	116±3	146±3	12	20	36
7%	75	LTFR0775B2	99	128.7	0.62	8	300	280±5	220±5	150	151±3	181±3	12	20	50
7%	100	LTFR0700B2	132	171.6	0.464	10	330	315±5	220±5	240	165±3	200±3	12	20	56
14%	1	LTFR1401B2	1.3	1.69	100.3	6	170	153±5	90±5	155	63±5	76±5	6	12	3.5
14%	2	LTFR1402B2	2.6	3.38	50.12	6	170	153±5	115±5	155	85±5	101±5	6	12	5.5
14%	3	LTFR1403B2	5.3	5.07	25.08	6	215	195±5	90±5	120	76±5	106±5	12	20	7.5
14%	4	LTFR1404B2	9.9	6.89	21.57	6	215	195±5	105±5	120	91±5	121±5	12	20	10
14%	5	LTFR1405B2	6.6	8.58	20.06	6	215	175	165±5	120	96±3	130±3	12	20	12.3
14%	10	LTFR1410B2	13.2	17.16	10.03	6	240	225	155±5	120	95±3	122±3	12	20	17
14%	12.5	LTFR1412B2	16.5	21.45	8.024	6	240	225	155±5	120	95±3	122±3	12	20	19
14%	15	LTFR1415B2	19.8	25.74	6.68	6	240	225	173±5	120	111±3	141±3	12	20	23
14%	20	LTFR1420B2	26.4	34.32	5.012	6	240	225	178±5	120	116±3	146±3	12	20	27
14%	25	LTFR1425B2	33	42.9	4.012	6	300	255	190±5	150	112±3	145±3	12	20	34
14%	50	LTFR1450B2	66	85.8	2.006	8	330	305±5	220±5	240	160±3	190±3	12	20	54.5
14%	75	LTFR1475B2	99	128.7	1.34	8	340	320±5	220±5	240	175±3	225±3	12	20	69
14%	100	LTFR1400B2	132	171.6	1.003	10	400	375±5	220±5	200	170±3	205±3	12	20	95

7% & 14% Detuned Reactor (Aluminium) 440 V - Overall Dimensions

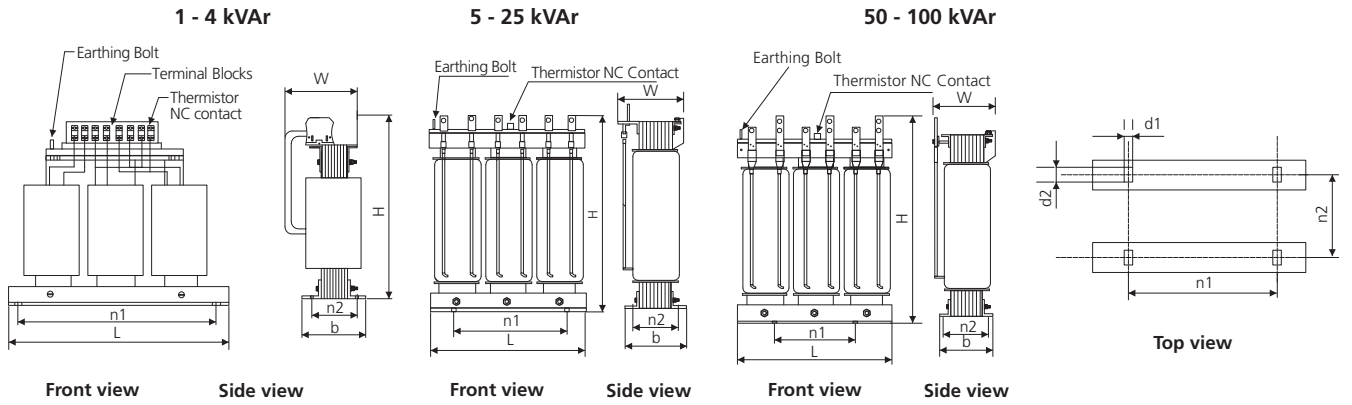

Tuning factor	kVAr	Cat. No.	Rated Current (A)	I rms (A)	Inductance (mH)	Terminal Hole	L	H	W	n1	n2	b	d1	d2	Weight (kg)
7%	1	LTAL0701B2	1.3	1.69	46.5	6	215	172±5	90±5	200	55±5	73±5	8	12	3.6
7%	2	LTAL0702B2	2.6	3.38	23.2	6	215	172±5	100±5	200	63±5	82±5	8	12	4.9
7%	3	LTAL0703B2	3.9	5.07	15.5	6	215	172±5	113±5	200	80±5	97±5	8	12	6.2
7%	4	LTAL0704B2	5.3	6.89	11.63	6	215	195±5	105±5	200	67±5	85±5	8	12	6
7%	5	LTAL0705B2	6.6	8.58	9.28	6	215	175	130±5	203	80±3	95±3	8	12	7
7%	10	LTAL0710B2	13.2	17.16	4.64	6	215	175	155±5	203	92±3	108±3	8	12	9
7%	12.5	LTAL0712B2	16.5	21.45	3.72	6	215	175	160±5	203	105±3	123±3	8	12	11
7%	15	LTAL0715B2	19.8	27.45	3.09	6	215	175	196±5	203	130±3	150±3	8	12	14
7%	20	LTAL0720B2	26.4	34.32	2.32	6	250	225	155±5	150	110±3	135±3	12	20	18
7%	25	LTAL0725B2	33	42.9	1.85	6	270	260	170±5	150	108±3	140±1	12	20	21
7%	50	LTAL0750B2	66	85.8	0.92	8	270	375	210±5	150	108±3	140±3	12	20	32
7%	75	LTAL0775B2	99	128.7	0.62	8	270	375	210±5	150	108±3	140±3	12	20	49
7%	100	LTAL0700B2	132	171.6	0.46	10	370	325	200±5	180	135±3	175±3	12	20	48
14%	1	LTAL1401B2	1.3	1.69	11.3	6	215	175±5	105±5	200	67±5	85±5	8	12	5.5
14%	2	LTAL1402B2	2.6	3.38	50.12	6	215	195±5	105±5	200	67±5	85±5	8	12	5.5
14%	3	LTAL1403B2	5.3	5.07	25.08	6	215	195±5	113±5	200	80±5	97±5	8	12	6.5
14%	4	LTAL1404B2	9.9	6.89	21.57	6	215	195±5	125±5	200	92±5	108±5	8	12	8.5
14%	5	LTAL1405B2	6.6	8.58	20.06	6	215	180	155±5	200	90±3	108±3	12	20	10
14%	10	LTAL1410B2	13.2	17.16	10.03	6	250	225	185±5	150	110±3	135±3	12	20	18
14%	12.5	LTAL1412B2	16.5	21.45	8.024	6	250	225	170±5	150	110±3	123±3	12	20	18
14%	15	LTAL1415B2	19.8	25.74	6.68	6	270	260	170±5	150	1130±3	160±3	12	20	26
14%	20	LTAL1420B2	26.4	34.32	5.015	6	270	260	195±5	150	150±3	180±3	12	20	31
14%	25	LTAL1425B2	33	42.9	4.012	6	270	360	175±5	150	110±3	135±3	12	20	34
14%	50	LTAL1450B2	66	85.8	2.006	8	370	305	230±5	180	135±3	175±3	12	20	47
14%	75	LTAL1475B2	99	128.7	1.24	8	370	305	270±5	180	180±3	215±3	12	20	68
14%	100	LTAL1400B2	132	171.6	1.003	10	350	410	260±5	205	180±3	205±3	12	20	82

The increasing use of energy saving power electronics based loads (adjustable speed drives, switch mode power supplies, etc.) to improve system efficiency and controllability, is increasing the concern for harmonic distortion levels in end use facilities and on the overall power system. Active filter is the apt device for reducing harmonic levels in industrial and commercial facilities to meet IEEE 519 guidelines. The concept of active filter, what many try to explain is, it senses harmonics and generates 180° phase shifted harmonics that cancels out the unwanted harmonics. This section, specifically describes the basic operation of active filters in a little more detailed way.

Principle of Operation

An active harmonic filter is based on the following principle:

$$I_{\text{FILTER}} = I_{\text{MAIN}} - I_{\text{LOAD}}$$

It detects the difference between the ideal current sine wave (I_{MAIN}) and the actual current which has been deformed by harmonics (I_{LOAD}). It, then, injects this difference (I_{FILTER}), which is the negative of the harmonic currents present in the load current, into the system on a real-time basis. This cancels out the high frequency harmonics and results in almost pure sine wave.

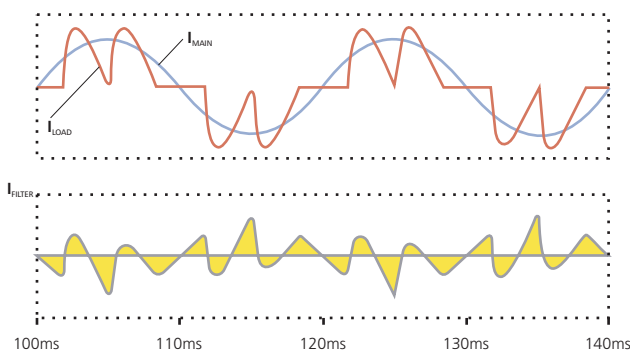

Wave Shapes of The Currents - I_{MAIN} , I_{LOAD} & I_{FILTER}

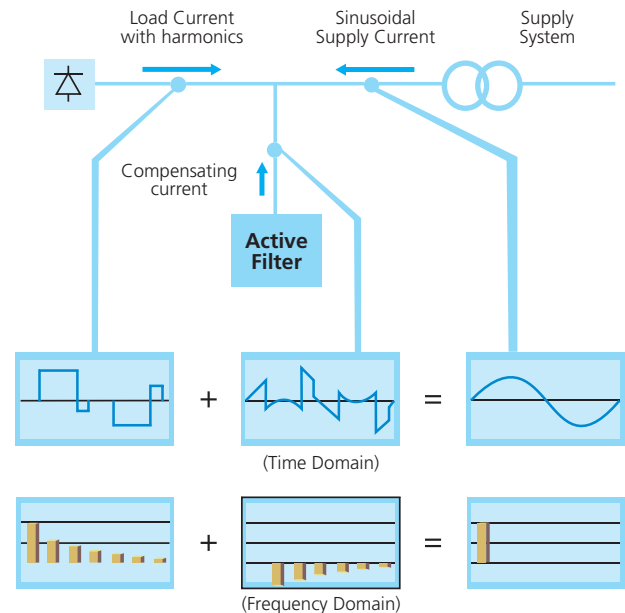

Line Diagram of Active Harmonic Filter

The use of active harmonic filters helps in reducing harmonics as can be seen under:

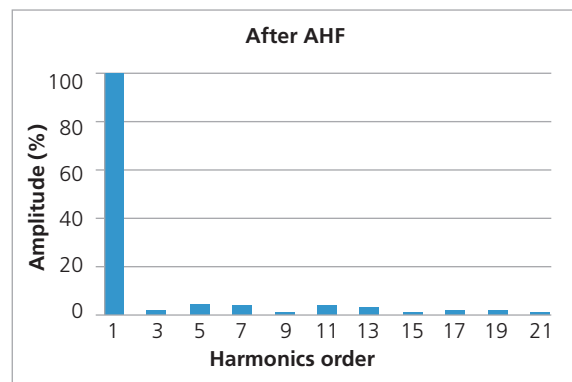
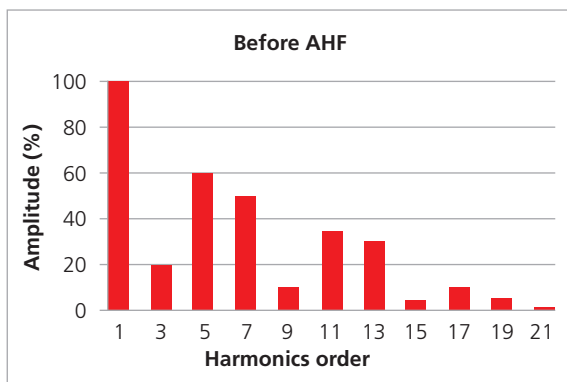

Frequency Spectrum of Current Before and After Active Harmonic Filtering

Some of the areas where active harmonic filters can be used are:

- In areas with critical loads like automobile industry, precision equipment manufacturing etc., the harmonic load may vary frequently. This may have immediate adverse impacts like poor quality of manufactured products and equipment failures leading to huge monetary losses. Active filters prove to be suitable as they provide real-time reduction of THD
- Certain segments like textile industry, having huge VFD loads suffer from high harmonics. Due to this, the use of detuned filters may not be adequate, resulting in frequent capacitor failures and overheating or saturation of reactors. Only active harmonic filters provide necessary solutions in such cases
- Active harmonic filters have an added advantage of providing unsymmetrical reactive power compensation and also, provide load balancing
- Even usage of 14% reactor may not be sufficient to reduce neutral overloading due to triple-N harmonics. However, 3 phase, 4 wire active filter helps in achieving the same more effectively

Active Harmonic Filters - Concepts & Connections

The active filter uses power electronic switching to generate harmonic currents that cancel the harmonic currents from a nonlinear load. The active filter configuration is based on a Pulse-Width Modulated (PWM**) voltage source inverter that interfaces to the system through an Interface Filter as shown in Figure 1. In this configuration, the filter is connected in parallel with the load being compensated. Therefore, the active filter with this configuration is often referred to as shunt active filter. Figure 1 illustrates the concept of the harmonic current cancellation so that the current being supplied from the source is sinusoidal.

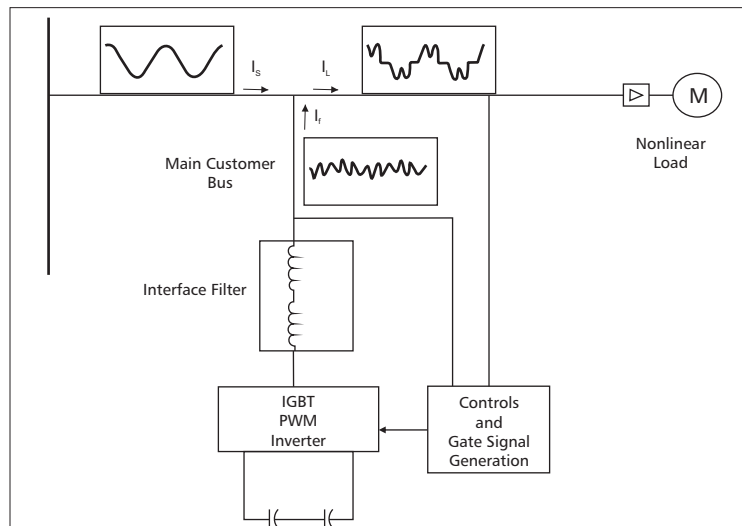

Figure 1

**Pulse Width Modulation is a technique used to generate the effect of any wave-form by varying the width of the DC pulse. The width (duty cycle) is varied by employing faster switching devices (IGBT with switching frequency in kHz). Higher the switching frequency, better will be the intended wave-form but higher will be the power losses.

The voltage source inverter used in the active filter makes the harmonic control possible. This inverter uses DC capacitors as the supply and can switch at a high frequency to generate a signal which will cancel the harmonics from the nonlinear load. One leg of the inverter is shown in Figure 2 to illustrate the configuration.

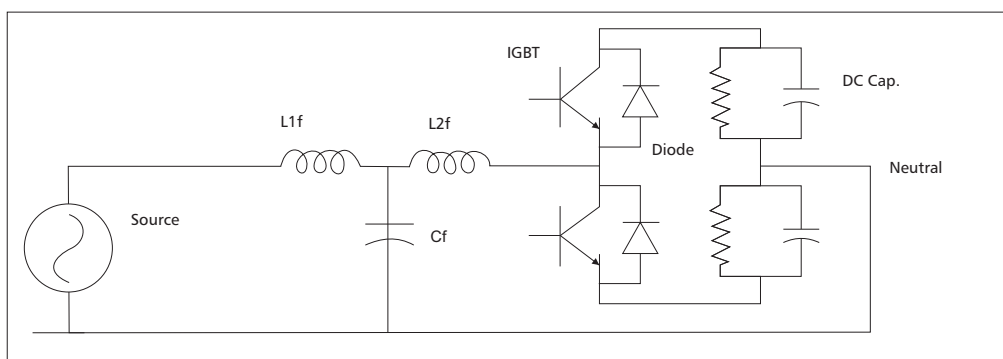

Figure 2

The current waveform for cancelling harmonics is achieved with the voltage source inverter and an interfacing filter. The filter consists of a relatively large isolation inductance to convert the voltage signal created by the inverter to a current signal for cancelling harmonics. The rest of the filter provides smoothing and isolation for high frequency components. The desired current waveform is obtained by accurately controlling the switching of the IGBTs in the inverter. Control of the current wave shape is limited by the switching frequency of the inverter and by the available driving voltage across the interfacing inductance.

The active filter does not need to provide any real power to cancel harmonic currents from the load. The harmonic currents to be cancelled show up as reactive power.

Connections & CT installations of Active Harmonic Filters

For the stable operation of active harmonic filter and for the expected reduction of harmonics, the physical connection & location of power cables & CTs plays a critical role. Let us understand the connections through the below two cases.

Case 1: In case any industry faces severe problems due to harmonics like over-heating of equipments, failure of power capacitors, frequent card failures, etc., it is advisable to arrest the harmonics right at the source. The connection shall be as below:

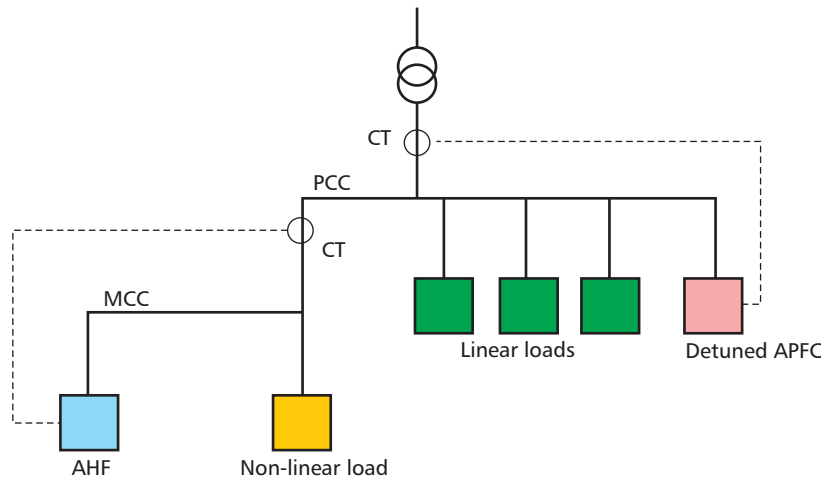

Make sure that the APFC panels are detuned and are connected in the upstream of the AHF. Detuning of APFC panel helps in optimising the AHF rating, as detuning avoids the harmonic amplification. Connecting AHF below the APFC avoids the AHF being overloaded due to unwanted harmonic resonances. Also make sure that the CT of AHF shall be connected below the CT of APFC panel.

Case 2: If almost all the main feeders from PCC generates high harmonics, ideally each feeder shall be compensated with individual AHF. But this will increase the installation cost and requires more space. Also managing all the AHF will be difficult. In such cases, a common AHF can be connected for harmonics compensation, as shown below:

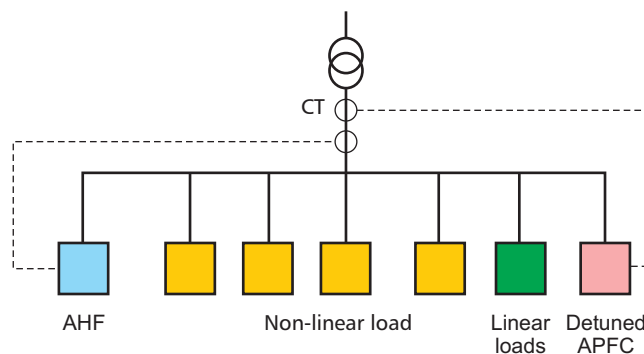

Also make sure that the APFC panels are detuned and the AHF CT shall be below the CT of detuned APFC panels. This method is also simple enough, especially for industries where harmonics need to be reduced at the HT side, in order to meet utility regulations (like Tamil Nadu Electricity Board).

In some rare cases, there may be multiple sources, like two or more synchronised transformers. In such cases, individual CTs shall be connected to each sources and the common signal can be given to AHF through a summation CT.

Open loop connection Vs closed loop connection

The open loop or closed loop connection is indicated by the location, where harmonics are measured by the AHF. In simple words, CT position states whether the connection is open loop or closed loop connection.

In **open loop connection**, CT is installed close to load, as indicated in the given figure. AHF senses the harmonics that are being generated by the load and generates the compensating harmonics based on that data. Advantage of this connection is faster harmonic compensation. But a drawback in this connection is, the AHF won't get any feedback from the system and does not know whether the harmonics compensation is happening properly or not. Also, as no feedback exists, the resulting line current may typically contain error components that are not detected by the control system. This connection works better when AHF is connected close to the load and not at PCC / main incomer.

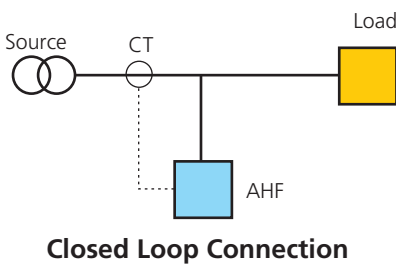
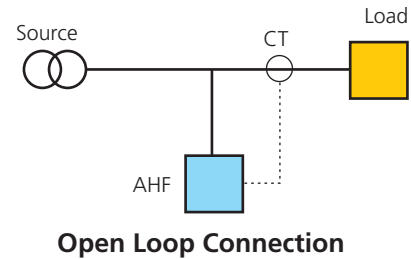

In **closed loop connection** the CT is installed close to source. Here, CT actually measures the compensated current. In other words, AHF senses the difference between load current and the AHF compensating current. If CT senses any harmonics, corrective action is taken by the AHF, till CT senses close to sine wave. In this method of connection, the AHF gets system feedback and any measurement or other inaccuracies can be automatically cancelled out. Even though, closed loop connection is not as fast as open loop, closed loop ensures better harmonics compensation. This type of connection works better, anywhere in the system, than the open loop.

Selection / Sizing of Nominal Current of Active Harmonic Filter

Active harmonic filter is rated in Amperes. The current rating is decided on the basis of harmonic content (THD) in the system which can be obtained from harmonic study. The required nominal current can be obtained by multiplying the initial current of harmonics measured in the load by a safety factor (SF_{in}) of 20%. In other words,

$$I_{\text{filter}} (\text{AHF}) = 1.2 \times I_{\text{load}} \times \% \text{THD (I)}$$

Where,

- I_{filter} (AHF) : Nominal Current of Active Filter (A)
- I_{load} : Maximum Load Current (A)
- % THD(I) : Load Current Harmonic Distortion (%)

Majority of the energy saving devices are non-linear in nature. Consequently, the problem of harmonics has become inevitable. Advanced devices like active harmonic filter provide an ideal solution to this problem. These filters help in maintaining a stable and healthy power system thereby increasing productivity and efficiency.

Active Harmonic filters are the most ideal solution for power quality problems caused, in either industrial or commercial facilities, for harmonic filtering, phase balancing and reactive power compensation.



Function

- Harmonic Filtering:**

The filters reduce harmonics up to the 50th order (2500 Hz) reducing distortion power factor. Selection of specific harmonic order for filtering helps in optimizing filtering efficiency.

3 Phase 4 Wire filter configuration ensures reduction in neutral current that can reach up to 200% of rated value due to triple-N harmonics.

THD TOTAL		
	LOAD	MAINS
L1	21%	5%
L2	18%	5%
L3	19%	5%

Harmonic Filtering

VOLTAGE & CURRENT			
	VOLTAGE	CURRENT	
		LOAD	MAINS
L1	232 V	199 A	220 A
L2	231 V	206 A	221 A
L3	231 V	255 A	221 A
FREQUENCY		50 Hz	

Phase Balancing

- Phase Unbalance Correction:**

This function ensures balanced current on the supply side in 3 Phase 4 Wire filter configuration.

- Power Factor Correction:**

This filter ensures close to unity displacement power factor for both lagging (inductive) and leading (capacitive) current systems. With improvement in both distortion and displacement power factor, true power factor is also improved.

POWER MAINS				
	P	Q	S	PF
L1	41.6 kW	5.92 kVAr	42.02 kVA	0.99
L2	38.9 kW	5.52 kVAr	39.29 kVA	0.99
L3	48.0 kW	6.80 kVAr	48.48 kVA	0.99

Reactive Power Compensation

Features & Benefits

Features	Advantages	Benefits
Employs floating Point 32 bit Digital Signal Processor	High accuracy & high attenuation up to 96% of individual harmonics	Effective harmonic mitigation
Programmable selective harmonic elimination		
Any number of units of different ratings can be connected in parallel	Modularity & expandability	Reduced Mean Time to Repair; Filter can be expanded as per future load requirements
Employs high speed IGBTs in power circuit	Faster response to change in THD and very high speed of operation	THD can be maintained even in case of very frequently changing load
Provision of Alarms	Easy diagnosis of fault conditions	Safety to devices and operators
7" TFT touch screen HMI	Easy configuration and parameter monitoring	Ease of installation and maintenance, User-friendly
Ethernet based communication	Remote monitoring	Ease of monitoring
Configuration in both open loop (load side sensing) and closed loop (source side sensing)	Faster response & higher attenuation of harmonics	Flexibility of configuration

The active filter is ideal in any application that has a large variation of loads, a wide spectrum of harmonics that must be compensated. Non-linear loads that are heavily distributed in the form of small network loads, so that it is not possible to use individual passive filters.

The most common applications are:

- Variable frequency drives
- Computer loads
- UPS
- CFL Lamps



In other words, its application is in any industry where large non-linear loads are present with high THD. Such high THD are prevalent in the following industries:

- | | | |
|-----------------------------|---------------------------|-----------------------------|
| • Automotive Industry | • Textile Industry | • Cement Industry |
| • Data Centres | • Paper Mills | • Oil & Gas Exploration |
| • Wind Turbines | • Sugar Plants | • Water Treatment |
| • Building & Infrastructure | • Pharmaceutical Industry | • Granite & Stone Polishing |

Connection Diagram

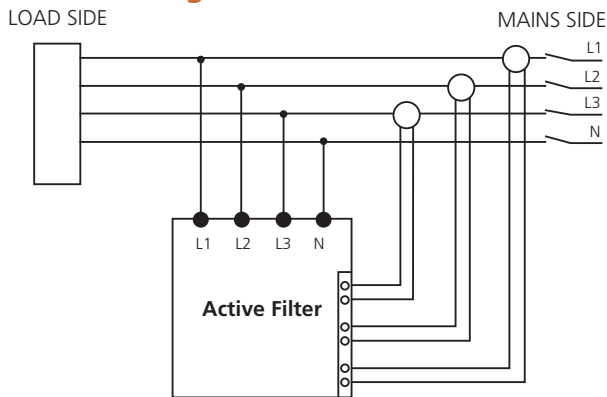

Close Loop Connection

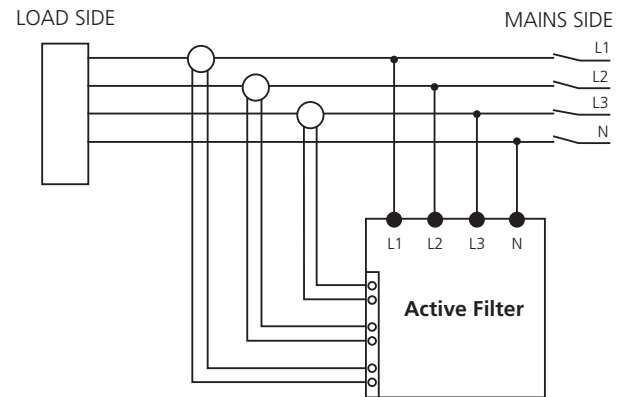

Open Loop Connection

Technical Specifications

INPUT											
Model	AHF - 4W/3W										
Normal Voltage	400V AC $\pm 10\%$, 3Ph 4 Wire/3 Wire										
Current Rating	30A	60A	75A	100A	150A	200A	225A	300A	400A	600A	800A
Frequency	50Hz, $\pm 5\%$										
FILTER											
Harmonic Range	2 nd to 50 th order										
Harmonic Selection	Any 20 Harmonic can be selected at a time										
Harmonic Attenuation Ratio	Up to 96% at rated current										
Response Time	<1 ms										
Function Selection	Harmonic filtering, Power factor correction, Load balancing										
Overload (peak value)	125% for 10 msec										
Current Transformer	30A	60A	75A	100A	150A	200A	225A	300A	400A	600A	800A
	500A:5A	1000A:5A	3000A:5A				5000A:5A		6000A:5A		
	Class 1, 15VA rating										
PHYSICAL CHARACTERISTICS											
Protection Class	IP20 (IP31 or IP41 optional)										
Cooling	Forced air										
Cable Entry	Front - Bottom										
ENVIRONMENTAL											
Operating Temperature	0 to 40° C										
Relative Humidity	95% (Non condensing)										
Maximum Operating Altitude without De-rating	1000 m										
Acoustic Noise at 1m From Panel Front (Ref ISO3746)	< 65 db			< 68 db				< 70 db			
USER INTERFACE											
User Parameter Setting	LCD touch screen HMI										
PROTECTIONS AND STANDARDS											
Protections	MCCB & fast acting semiconductor fuses										
Alarms	DC over voltage, Over load trip, Over temperature alarm & trip, Over current, No synchronisation, Mains abnormal, DC under voltage, Active filter trip, Wrong phase, No faults, Fast DC overvoltage, Inductor over temperature trip										
Reference Design Standard	IEC 60146										
Safety Standard	EN 50178										
Electromagnetic Compatibility	EN 55011, IEC EN 50081-2, IEC 61000-4-2, IEC 61000-4-3, IEC 61000-4-4, IEC 61000-4-5, IEC 61000-6, IEC 61000-6-2										

Modularity & Expandability:

1. Expandability: Modules of 75, 100 & 200 A can be added in the below AHFs without replacing the existing panel.

AHF Rating	Module Rating	No. of Modules	Expandable to	Additional Module Rating	Additional No. of Modules
150	75	2	225	75	1
200	100	2	300	100	1
400	200	2	600	200	1

For example in the image of 150 A AHF, currently 2 modules of 75 A are present & the top rack is empty. This same Filter can be expanded to 225 A by adding a single module of 75 A at the top rack.



2. Paralleling: The available rating of the filter can be increased by connecting any number of units in parallel considering future load demands. A single CT can be used for connecting upto 4 units in parallel. Additional CTs must be installed if more than 4 AHFs are to be used in parallel configuration. Paralleling is possible in AHFs which have the same rating of modules.

For example, 300A AHF, which has 3 numbers of 100A modules can be paralleled with 200A AHF which has 2 numbers of 100A module or another 300A AHF. But it cannot be paralleled with 150A AHF which has 75A modules

3. Replaceability: If any module becomes faulty during operation, it can be replaced by another module of similar rating without affecting the operation of the rest of the filter. This reduces the downtime of AHF.

Overall Dimensions

AHF - 3W/4W 30/60/75/100

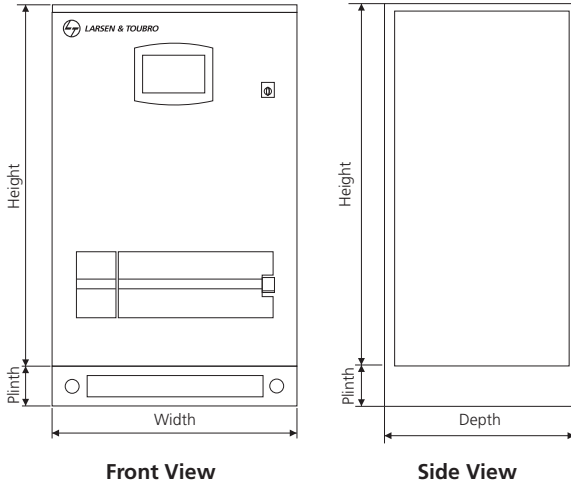

3 Ph 3 Wire / 4 Wire, 400 V Active Filter							
Cat. No.	Model No.	Cable size- Copper single core flexible	Weight (kg)	Dimensions (mm)			
				Width	Depth	Height	Plinth
AHF030331D2	AHF - 3W- 30A	4x10 sq.mm	45	550	300	800	Wall-Mounting
AHF030341D2	AHF - 4W - 30A	6x25 sq.mm	48				
AHF060331D2	AHF - 3W- 60A	4x25 sq.mm	65	620	450	1000	100
AHF060341D2	AHF - 4W - 60A	6x25 sq.mm	70				
AHF075331D2	AHF - 3W- 75A	4x35 sq.mm	75	620	450	1000	100
AHF075341D2	AHF - 4W - 75A	6x35 sq.mm	80				
AHF100331D2	AHF - 3W- 100A	4x50 sq.mm	85	620	450	1000	100
AHF100341D2	AHF - 4W - 100A	6x50 sq.mm	90				

AHF - 3W/4W 150/200/225/300/400/600/800

3 Ph 3 Wire / 4 Wire, 400 V Active Filter							
Cat. No.	Model No.	Cable size- Copper single core flexible	Weight (kg)	Dimensions (mm)			
				Width	Depth	Height	Plinth
AHF150331D2	AHF - 3W- 150A	4x70 sq.mm	175	800	850	1600	150
AHF150341D2	AHF - 4W- 150A	6x70 sq.mm	205				
AHF200331D2	AHF - 3W- 200A	4x70 sq.mm	225	800	850	1600	150
AHF200341D2	AHF - 4W - 200A	6x70 sq.mm	265				
AHF225331D2	AHF - 3W - 225A	4x100 sq.mm	250	800	850	1600	150
AHF225341D2	AHF - 4W - 225A	6x100 sq.mm	300				
AHF300331D2	AHF - 3W- 300A	4x120 sq.mm	310	800	850	1600	150
AHF300341D2	AHF - 4W - 300A	6x120 sq.mm	365				
AHF400331D2	AHF - 3W- 400A	4x(2x70) sq.mm	430	1000	900	1600	150
AHF600331D2	AHF - 3W- 600A	4x(2x120) sq.mm	600	1000	900	1600	150
AHF800331D2	AHF - 3W- 800A	4x(2x140) sq.mm	970	1350	900	1600	150

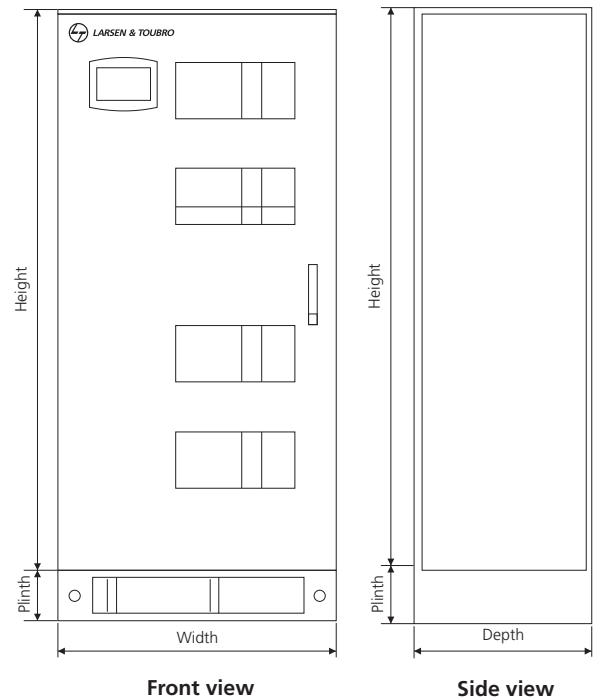

Defining Power Factor

Power factor is usually identified as the cosine of angle between the voltage sine wave and the current sine wave. For a better understanding, it can be seen as the efficiency of electricity consumption. Similar to the efficiency of a machine, it can be defined as the ratio of output power rendered by the machine to the machine input power. Hence, it is the ratio of True power (kW) to Apparent Power (kVA).

$$\text{Power factor (PF)} = \frac{\text{kW}}{\text{kVA}}$$

However, it is not the only power factor present in the system. Depending on which value of voltage and current we consider, there are different types of power factors:

- Displacement PF
- Distortion PF
- True PF

Types of Power Factor

1. Displacement PF – The power factor which is due to the phase shift between voltage and current at the fundamental frequency is known as displacement power factor.

$$\text{Displacement PF} = \frac{P}{V_1 I_1}$$

2. Distortion PF – The power factor which includes the effect of harmonics present in the system is called distortion power factor.

$$\text{Distortion PF} = \frac{1}{\sqrt{1 + \%i\text{THD}^2}}$$

3. True PF – It is defined as the ratio of average power to apparent power.

Both the above power factors together combine to form the True power factor.

$$\text{True PF} = \text{Displacement PF} \times \text{Distortion PF}$$

$$\text{True PF} = \frac{P}{V_{\text{rms}} I_{\text{rms}}}$$

Different types, different implications

Understanding the various types of power factor is very important because all three have different implications.

When we talk about power factor correction by means of capacitors, we are referring to improvement of only the displacement power factor, which consequently improves the true power factor. Capacitors act like an alternate "source" of reactive power and hence by decreasing the "inductiveness" of the system, they reduce the lag between the current and voltage phase, thus improving the power factor. But it is important to note that these voltage and current waves are with respect to the fundamental component i.e. 50 Hz. There might be some cases where even after installing capacitors at site, the power factor doesn't improve.

Here distortion power factor comes into picture.

Under normal load conditions,

$$\text{kVA} = \frac{\text{kW}}{\text{PF}}$$

Here, the system current is the rms current at 50 Hz.

For pure sinusoidal cases (systems without Harmonics),

$$\text{PF}_{\text{true}} = \text{PF}_{\text{disp}} = \cos \phi$$

where ϕ is the angle between voltage and current wave

In case of a system with Non Linear loads, when the system is polluted by harmonics, the rms current increases as seen by the following formula –

$$I = I_1 \sqrt{1 + i\text{THD}^2}$$

Increase in rms current consequently leads to increase in kVA demand. But the kW output of the system would remain the same.

Following the formula $kVA = \frac{kW}{PF}$,

If kVA demand increases with kW remaining constant, power factor has to decrease. This decrease in power factor due to the presence of harmonics can be attributed to the 'distortion power factor'. Here true power factor becomes a product of displacement and distortion power factor. Hence, even if the displacement PF is corrected up to unity, the true PF will still remain low because of poor distortion PF.

Mathematically, distortion PF can be calculated as :

$$PF_{\text{dist}} = \frac{1}{\sqrt{1 + iTHD^2}} = \frac{I_1}{I_{\text{rms}}}$$

where I_1 is the rms value of the fundamental current and I_{rms} is the rms value of total current.

Harmonic levels are measured as Total Harmonic Distortion (THD). Higher THD implies lower distortion PF. The graph below depicts the impact of THD levels on the true power factor of non linear loads.

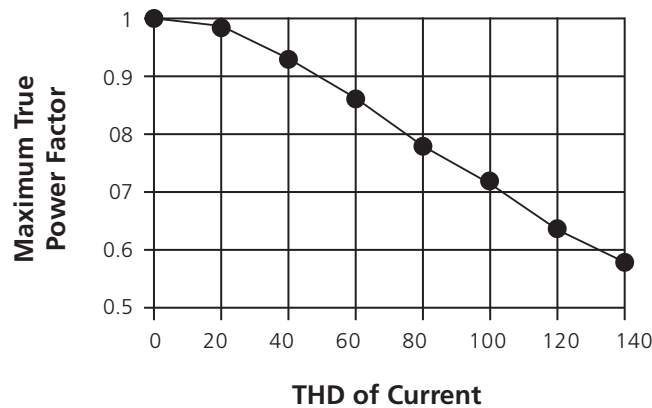

The following table shows how different types of power factor vary with THD.

THD-I	Displacement PF (assumed to be compensated by equivalent Capacitors)	Distortion PF	True PF
5%	0.999	0.999	0.998
30%	0.999	0.958	0.957
40%	0.999	0.929	0.928

Capacitors don't do any good in correcting distortion power factor. In harmonic rich environment, using capacitors can even be detrimental to the installation as it can lead to harmonic resonance and harmonic amplification. Hence, in such cases, we need to use detuned reactors along with capacitors to avoid amplification.

APFC panels with detuned filters can effectively increase the displacement pf to unity. But the distortion pf will still remain low due to the presence of harmonics in the system. And hence, the true power factor will remain low, as seen in the above table. Thus, to improve distortion PF, Active Harmonic Filter should be used to mitigate harmonics.

The smart choice

For improving true power factor, correction of both displacement and distortion power factor is required. Capacitors are the means for improving solely the displacement power factor. But we can't overlook the repercussions of using capacitors alone in systems with high harmonics. In a harmonics rich environment, Active Harmonic Filter must be used to improve distortion PF. Hence, for power factor correction, hybrid filter (capacitor-reactor combination with AHF) is the smart choice.

Difference between Diesel Generator Sets and Power Grid

The electrical grid is an enormous source of power and can be referred to as infinite bus. There are innumerable loads connected to the grid and a change in any of those loads accounts to only a small fraction of the total grid capacity. The effect of load changes are less on the grid, in terms of stability of supply voltage. It can be called a 'stiff' power source or having high inertia. Diesel generators (DG) sets, however, are used as a backup supply or even permanent power source in some systems. As any change in load connected to the DG set accounts for a considerable percentage of its total capacity, it can easily affect its output voltage. DG responds to any small change in current demand immediately, even at the expense of output voltage. It means DG set has low inertia and can be called 'soft' power source.

Another difference between grid and Diesel Generator sets is that DG sets have a very high source impedance that can be as high as 25-30%, as compared to transformer impedance of 3-5%. Hence, the short circuit breaking capacity of the Short Circuit Protection device (SCPD) used under the grid is higher as compared to SCPD used for loads connected with a DG set. It is important to note that harmonic distortion is a function of source impedance. As the steady state impedance in case of DG set is very high, presence of even small amount of I-THD creates large V-THD when it travels through the high impedance.

Let us consider an example with a total load current of 1000 A in which 700 A is the nonlinear current. Here, nonlinear loads are drives with harmonics of say 55%

$$I\text{-THD} = \frac{0.55 \times 700}{1000} \times 100 = 38.5\%$$

V-THD can be calculated considering transformer impedance of 5% in case of grid and DG impedance of 30% in case of Diesel Generator.

For the said % I-THD, approximate values of % V-THD are indicated as follows:

Source (%Z)	% I-THD	% V-THD
Electricity Grid (5%)	38.5	1.92
Diesel Generator (30%)	38.5	11.5

Therefore, it can be clearly seen that due to higher source impedance in case of DG set, the same I-THD leads to a higher levels of V-THD.

Due to the differences in the two sources, DG sets behave differently in presence of harmonics. This section discusses about the impact of harmonics on Diesel Generators and the ways to mitigate the effects.

Impact of harmonics on Diesel Generators

Some important effects in Diesel Generators in the presence of harmonics are:

1) Flat topping

As discussed at the outset, Diesel generator is a soft source, which means it cannot sustain sudden changes in load very well. Majority of the non-linear loads in industries are variable frequency drives (VFD), which consist of a rectifier, a DC bus and an inverter. The capacitors of VFD's DC bus pull the current when the incoming sine wave voltage is higher than the DC bus capacitor voltage, which happens near the peak of the incoming AC Voltage. When the total VFD loads account for a significant percentage of the genset capacity, such current drawn at the peaks will cause a sudden increase in demand from the DG. The DG being a "soft" source responds to this current demand immediately at the cost of output voltage. The voltage at DG output will drop. The AVR starts regulating and brings the voltage to the required level. But before the instant when voltage reaches the required level, the DG voltage is already clipped, this is called "flat topping". The voltage waveform occurs to be flat as seen in the following graphs:

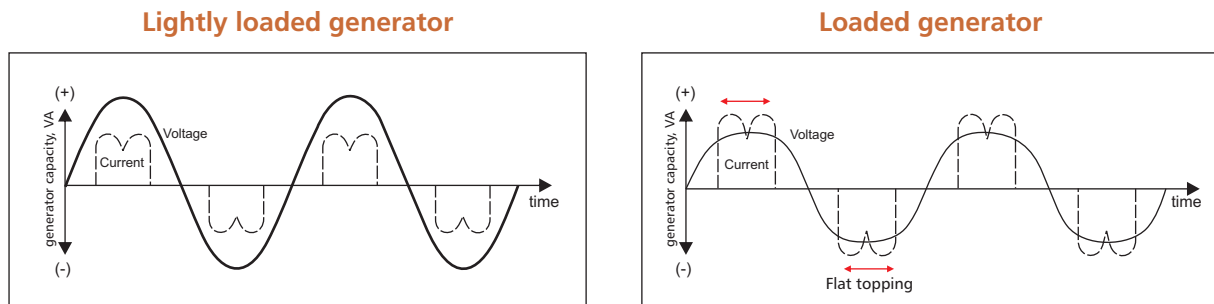

As can be seen from the graphs, flat topping of the voltage waveforms increases with the increase in generator loading. Flat topping can reduce the actual system peak to peak voltage to levels as low as 70% of the RMS voltage. This reduction creates an excessive flow of current through the system which can lead to burn out of machines.

2) Automatic Voltage Regulator malfunction

Presence of voltage distortions implies defective functioning of one of the most critical equipment for a generator, which is the Automatic Voltage Regulator (AVR). AVR senses any change in the voltage levels due to changes in load and adjusts the excitation of the generator accordingly to maintain the same level of voltage output. In the presence of nonlinear loads, distortion in voltage supply and flat topping adds additional burden to the Automatic Voltage Regulator (AVR) of the genset as it tries to compensate the voltage drop by increasing the voltage. In the presence of harmonics, the AVR won't be able to sense the voltage changes accurately due to highly distorted voltage wave. As the excitation won't be as per the correct requirement, the output voltage of the generator would suffer which leads to instability.

3) Losses and overheating

Diesel Generator includes an IC Engine working as the prime mover for the generator. Engine generates a lot of heat, which gets amplified in the enclosed environment of the Genset. Hence, heating in Diesel Generators is a bigger issue as compared to heating in transformers. Harmonics being high in frequency cause high frequency flux change in the stator leading to heating of the stator core. Increased current in the system also lead to copper losses in the armature, which in turn lead to further overheating. High harmonic currents also lead to eddy current losses in the rotor. Increased losses of various kinds degenerates the machine efficiency and life. Other effects include skin effect and insulation failure.

4) Vibrations

Certain Harmonic currents which have a negative phase sequence, on interacting with the magnetic field generate torque in opposition to the machine rotating torque. A resultant pulsating torque is generated which leads to vibrations in the machine. It is detrimental to the machine life.

Impact of Harmonics on sizing of Diesel Generators

Generator manufacturers recommend derating the Diesel Generator in presence of harmonics in such a way that the total non-linear loads under a genset should be less than 40% of its total capacity (as recommended by most genset manufacturers; may change from manufacturer to manufacturer). For better understanding, consider the following example.

Case 1: Suppose the DG rating is 1000 kVA

$$\text{Total current} = (1000 \times \text{kVA}) / (\sqrt{3} \times \text{V}) = (1000 \times 100) / (\sqrt{3} \times 440) = 1312.16 \text{ A}$$

$$\text{Hence, total nonlinear current should be less than } 0.40 \times 1312.16 = 524.86 \text{ A}$$

Case 2: If the nonlinear current increases in the system as a result of increased drive loads to say 700A

$$\text{Then the DG should be sized as per current of } (700 \times 100) / 40 = 1750 \text{ A}$$

$$\text{DG in this case should be rated at } (\sqrt{3} \times \text{V} \times \text{I}) / 1000 = (\sqrt{3} \times 440 \times 1750) / 1000 = 1330 \text{ kVA}$$

Result: In this case, increase in nonlinear loads has increased the size of the generator by 25%.

Mitigation of Harmonics in Diesel Generators and PF correction

Derating the DG set is not a permanent solution. Increasing the DG size leads to increased costs and increased fuel consumption. This remedy is neither feasible nor economical.

To avoid malfunctioning of AVR under high harmonic levels, a harmonic filter can be incorporated in its sensing circuitry, but this option is quite expensive and doesn't deal with the presence of harmonics.

Many DG manufacturers do not recommend the use of capacitor banks with DG. Even when capacitor banks are used to maintain the power factor of 0.8, which is the optimum power factor for majority of DGs, presence of harmonics in the system will lead to premature failure of capacitors. Life of capacitors connected to DG set would be less than life obtained when they are connected to the grid for the same current harmonics level (this is due to higher voltage harmonics at the same given current harmonics).

In order to limit the levels of distortion, detuned filters can be used along with 525 V capacitors for preventing harmonic amplification. But as V-THD is high in this case, use of normal reactors is not recommended as there are high chances of reactor burnout. In such systems with high harmonic distortion, special reactors for high V-THD withstand should be used. Best solution for getting rid of the effects of harmonics in systems with DG is by eliminating the harmonics using an Active Harmonic Filter. Active filter senses the exact amount of harmonic levels in the system and eliminate their presence by pumping anti-harmonics.

It is important to note that as soon as we connect AHF near to the load, the load which was earlier seeing the high source impedance due to DG set will now see a very low impedance due to AHF. Hence, there would be high I-THD circulating between the AHF and the load. In such a case the sizing of the AHF needs to be done considering a higher safety factor. Sizing of AHF under a transformer is done with a safety factor of 20%, whereas for AHF under DG systems, a safety factor of 35% should be considered.

$$\text{AHF rating (A)} = 1.35 \times \text{load} \times \% \text{ I-THD}$$

In conclusion, where high V-THD and I-THD are expected, as in case of DG sets, Active Harmonic Filter would be the best solution. For cases which also aim at PF improvement, combination of 525 V MPP Capacitors and reactors with high V-THD withstand capability is recommended.



The switching of capacitor banks is a special and challenging task in Automatic Power Factor Correction (APFC) panels. The selection of appropriate switching device for such application is based on two criteria:

- Ability to carry rated capacitor current continuously
- Ability to withstand the peak-inrush current of capacitor

It is simple to calculate the capacitor rated current and select the switching device to be able to carry rated capacitor current (2.5 to 3 times the capacitor rated current to take care of overload, harmonics, supply voltage variation and capacitor value tolerance). However, it is little difficult to select the switching device which is able to withstand the peak-inrush current. This is because the peak inrush current for capacitor switching application depends upon various factors such as:

- The inductance of the network (including cables, switchgears and transformer)
- The transformer power rating and percentage impedance
- Method used for power factor correction
 - Fixed capacitor bank
 - Multi-stage capacitor bank with steps of equal ratings
 - Multi-stage capacitor bank with steps of unequal ratings
- In multi-stage capacitor bank, the numbers and rating of steps already switched on

In most of the installations, the multi-stage capacitor banks are used as steps of unequal ratings. The bigger steps of higher kVAR ratings being switched on initially and smaller steps are switched on periodically, for achieving the targeted power factor. In such cases, the value of inrush-current peak will be far higher and hence the smaller capacitors will be heavily stressed.

Capacitor switching can be done by various ways like:

Power Contactor

- Normal power contactors simply allow the inrush current to flow through it. Because of this, contactors and capacitors are heavily stressed. So the contactor selection should be such that it withstands the heavy inrush current. Hence, power contactors need to be heavily de-rated.
- This inrush current also stresses the power capacitors and may result in their premature failure.
- Power contactors should be used along with inrush current limiting resistors, for reducing the magnitude of inrush current. However, this increases the cost & size of the APFC panel along with extra power losses.

Capacitor Duty Contactor

- Capacitor duty contactors can be used to limit the inrush current to less than $10 \cdot I_N$.
- Capacitor duty contactors have pre-contacts/auxiliary contacts with current limiting resistors (of 4Ω). At the moment of switching, the pre-contacts (with resistors) close first. This reduces the inrush current to less than $10 \cdot I_N$. After a few milliseconds, main contacts are closed and the pre-contacts will open and go out of the circuit.
- Capacitor duty contactors are employed where the frequency of switching is less i.e., the load fluctuation is not very fast. The capacitor requires atleast 60 seconds to discharge to a nominal value (50 V). So capacitor duty contactors cannot be used when load fluctuation is heavy.

Thyristor Switching Module (TSM)

- TSM is a static switching device that is used specially for switching capacitors (dynamic power factor correction), wherever the load fluctuation is heavy (like welding, steel rolling, etc.).
- Rapid switching (5 ms to 20 ms) is possible with TSM along with Quick Discharge Resistor (QDR).
- There is no inrush current while using TSM (zero voltage switching). So frequent switching does not affect the life of capacitors and there is no need for extra current limiting resistors.
- TSM has thermal cutoff, which switches off the module when temperature exceeds beyond a certain limit. It automatically switches on when optimum temperature is attained.

Capacitor switching always remains as one of the challenging operations. Capacitor draws very high inrush current for a very short duration. Due to this, life of all the devices in the circuit Like capacitor, contactor, short circuit protection device (SCPD) and cables are affected. They all are subjected to thermal & electrical stress, each time the capacitor is switched on & off. Various switching options are available like Power Contactors (AC3 duty) & Capacitor Duty Contactors (AC6b duty). In spite of good options of AC6b contactors available, switching capacitor through AC3 contactor is very popular even now.

Issues while switching with AC3 duty contactors:

Even today, majority of the users employ power contactors (AC3 duty) to switch capacitors in APFC panels. In order to ensure the contactor withstands both the inrush current and capacitor current along with harmonics, as a rule of thumb, contactor is simply derated to 2 to 2.5 times the rated current. For example, in order to switch 100 kVAR capacitor, they select 225 A (MNX 225) AC3 rated contactor.

Use of AC3 duty contactors, derated as per thumb rule, is generally not recommended, as they do not limit the inrush current. This increases the probability of failure of capacitors due to damage of metal spray layer (as shown in fig) because of High inrush current magnitude & frequency. If MCCBs are used as SCPD, their contacts would bounce due to high inrush current and may get damaged (pitting & carbon formation). The high inrush current may result in nuisance operation of fuses as well. Such issues in SCPDs are very well documented in various sites.



Issues while switching with AC3 duty contactors with series detuned reactors:

Some users believe that when detuned reactors (7% or 14%) are used along with capacitors, the inrush current would reduce. It is true to some extent, but the time duration of high frequency oscillation is actually longer than switching pure capacitors. This also increases the peak transient voltages and the same is applied across the capacitors. This causes high voltage stress to the capacitors and the dielectric may fail prematurely.

Switching with Capacitor Duty Contactors (AC6b):

The next best option is use of capacitor duty contactors with pre-closing resistors (as shown in fig). Though they do not have a point-on wave control, they are very effective in controlling inrush currents due to the presence of pre-closing resistors. The resistance value is generally in the range of 2 to 6 Ohms, with 4 ohms being typical. Considering a system voltage of 440 V and a 25 kVAr capacitor, the rated current is 32 A. Even when switched at the peak of the voltage and assuming that capacitor behaves as a complete short circuit, the current would be limited to a peak of 155 ($440 \times 1.414 / 4$), which is just 3.5 times the rated peak current (32×1.414). In practical cases the actual inrush current could be much lower considering other circuit impedances and the probability that the switching could happen at any point on wave, including voltage zero.

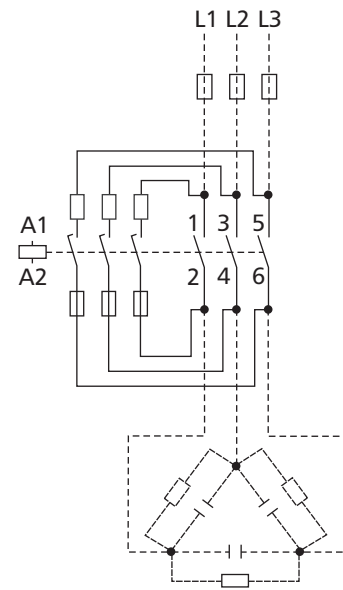

AC6B duty contactors also help damp the switching transient oscillation due to the insertion of a ohmic resistance in the circuit during switching instant. The presence of this resistance effectively damps the transient and reduces the duration of oscillation.

The switching performances of AC3 and AC6b duty contactors, with and without 7% series reactors has been compared through simulation.

Simulation:

- 25 kVAr, 440 V capacitor with rated current of 32 A is considered
- Single-phase equivalent circuit is considered with voltage of 254 V rms (L -N), V_{peak} of 360 V (equivalent to 440 VL-L, three phase).
- 5 ms time lag between resistor contacts and main contacts in case of AC6B contactors is considered
- Lead inductance per step = 1.7uH, 7% reactor per step = 1.7 mH
- Observe the duration of transient, which is very short in some cases
- In some cases the voltage / current is amplified due to resonance at switching frequency
- In practical cases, the circuit would be more complex with additional lead inductances, straycapacitance and distributed ohmic resistances and generally will have a higher damping
- Practical values could be slightly different from due to simplified circuit used for simulation
- 10x capacitors switched at peak voltage with AC3 & AC6b contactors and with & without 7% detuned reactors.
- In the below results,
 - First waveform represents supply voltage
 - Second one represents Capacitor current and
 - Third one is the Voltage across capacitor terminals

1. 10X parallel capacitor bank with AC3 and no series reactor, switching at peak voltage

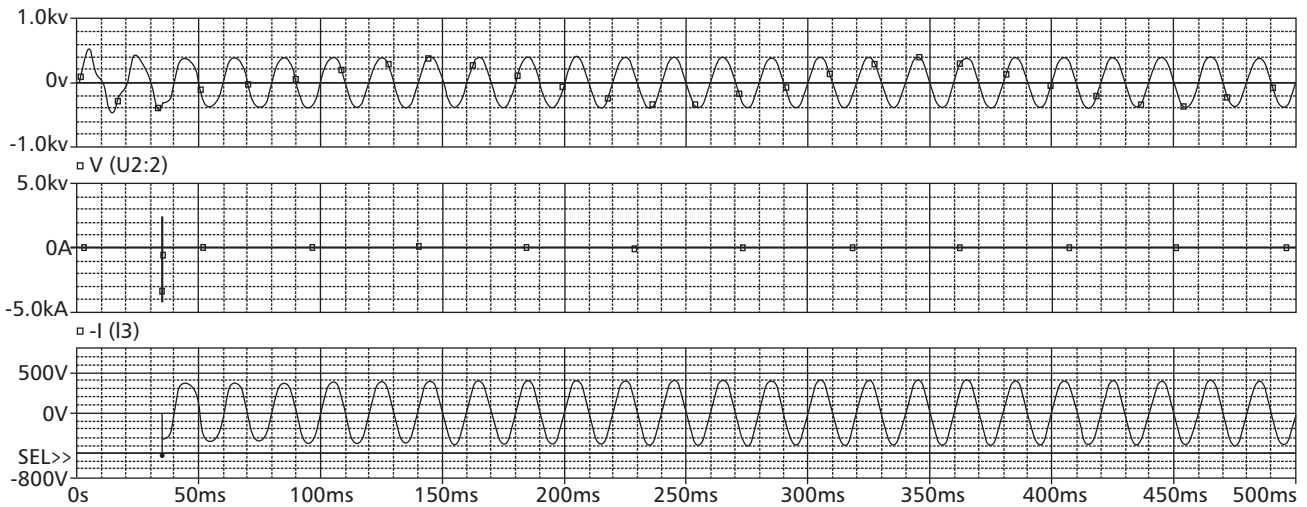

$I_{peak} = 4000 \text{ A}$

V_{peak} across the capacitor = 415 V

2. 10X parallel capacitor bank with AC3 and with 7% series reactor, switching at peak voltage

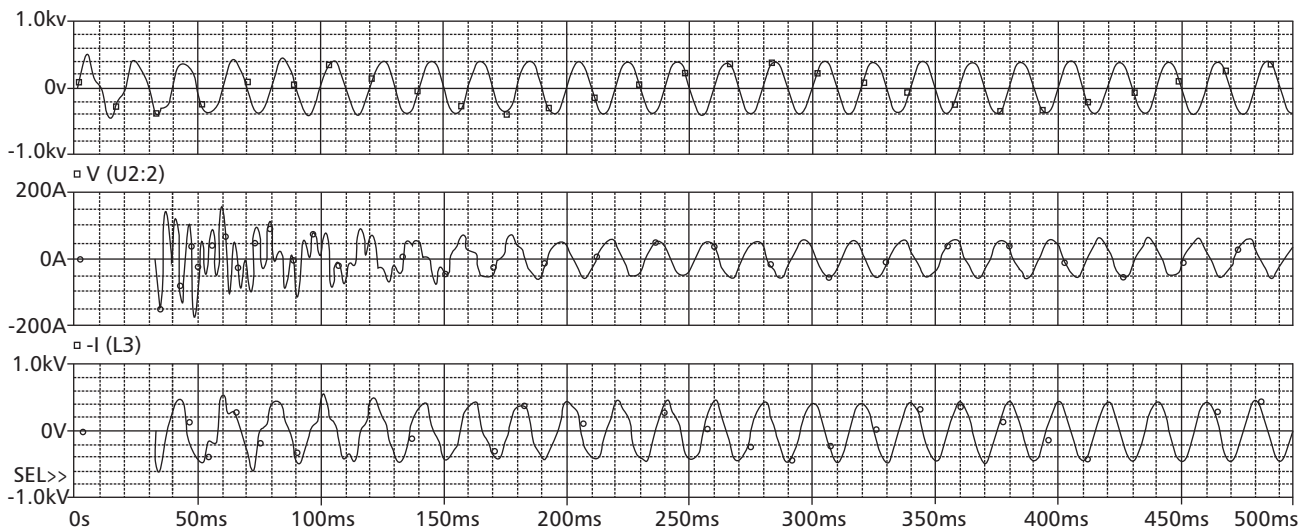

$I_{peak} = 200 \text{ A}$

V_{peak} across the capacitor = 600 V

3. 10X parallel capacitor bank with AC6B and no series reactor, switching at peak voltage

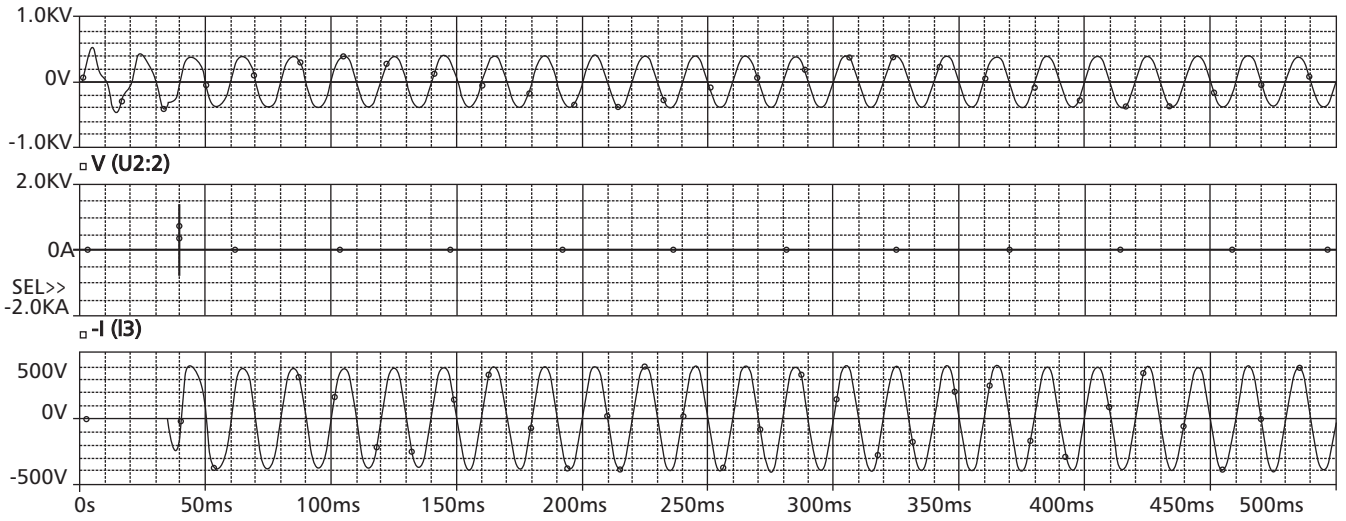

$I_{\text{peak}} = 1400 \text{ A}$

$V_{\text{peak across the capacitor}} = 400 \text{ V}$

4. 10X parallel capacitor bank with AC6B and with 7% series reactor, switching at peak voltage

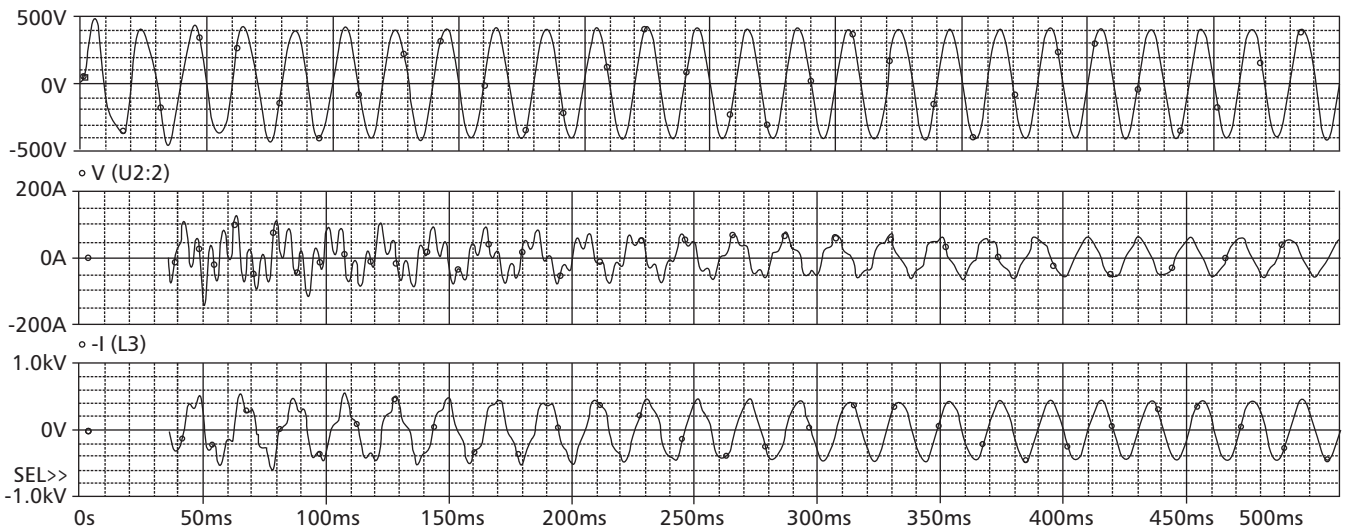

$I_{\text{peak}} = 140 \text{ A}$

$V_{\text{peak across the capacitor}} = 565 \text{ V}$

Summary:

Below table is the summary of above simulation, where the peak inrush current values and peak transient voltages across capacitors are shown:

		AC3 contactor	AC6b contactor
10x parallel banks	With 7% reactor	$I_p = 200 \text{ A}$	$I_p = 140 \text{ A}$
		$V_p = 600 \text{ V}$	$V_p = 565 \text{ V}$
	w/o reactor	$I_p = 4000 \text{ A}$	$I_p = 1400 \text{ A}$
		$V_p = 415 \text{ V}$	$V_p = 400 \text{ V}$

What is important is not just the peak value, but duration of peak and duration of oscillations. Below table represents the duration of some:

Parameters	AC3 duty	AC6b duty	AC3 duty + reactor	AC6b duty + reactor
Peak current	450 A	190 A	220 A	115 A
Peak voltage	700 V	480 V	750 V	520 V
Duration of oscillation (current)	Up to 150 ms	Up to 130 ms	Up to 500 ms	Up to 400 ms
Duration of oscillation (voltage)	Up to 110 ms	Up to 90 ms	Up to 400 ms	Up to 200 ms

From the above tables it can be inferred that:

- Traditional method of using power contactors results in very high peak inrush current & voltage.
- Another traditional method of using power contactors along with series reactors (0.2% or 7%), though reduces the peak current value, still there is a significant increase in peak transient voltage and duration of oscillations. This is more dangerous to capacitors & switchgear.
- If reactors are used along with capacitors, switching with capacitor duty contactor will reduce both current & voltage peak values due to the addition of ohmic resistance (R) in series. This also reduces the duration of oscillation.
- Higher peak currents / voltages observed in some cases is not due to switching transients, but due to possible resonance at switching frequency as can be observed from the wave shape (oscillations with DC offset and first peak lower than subsequent peaks)

As the results indicate, reducing inrush current by introducing resistance in the capacitor circuit is the best method, whether with or without reactors. Usage of derated Power Contactors (AC3) will just withstand the inrush current. From cost point of view, derated AC3 contactors will be more expensive than AC6b equivalent. Addition of inductance with AC3 contactor results in increased oscillations and can cause failure of capacitor & contactor itself. Trouble free operation of all the components in APFC panels are very important because the user may end up paying huge penalty, in case power factor is not maintained above the prescribed limits. Proper switching with capacitor duty contactor is one of ways of ensuring that.



MO C Capacitor Duty Contactors are specially designed for capacitor switching applications. As capacitor switching is associated with high inrush current, the contactors are provided with damping resistors which limit the value of inrush current to a safe value. The contactors are used in APFC panels for switching power capacitors depending upon the amount of reactive power compensation required.

Benefits of using Capacitor Duty Contactors

Since switching of capacitor banks involves high transient inrush currents, the size of the contactor required to switch these high currents becomes higher. Hence, current limiting inductors are used in series to attenuate this inrush current. This increases the system cost and panel space.

A typical case below illustrates the magnitude of transient inrush current for switching of a capacitor bank. For a 12.5 kVAr capacitor bank:

Rated current of 12.5 kVAr 415 V Capacitor = 18A
Peak Inrush current without Damping Resistors = 1200A

Capacitor Duty Contactors are designed to limit this high transient inrush current by introducing damping resistors with early make auxiliary contacts. The current limiting due to damping resistors protects the APFC system from harmful effects of the capacitor charging inrush current.

Peak Inrush current with Damping Resistors = 260A

It is observed that peak inrush current with damping resistors is one fifth of that without damping resistors. As the contactor is now required to switch the rated capacitor current, the size of the contactor required is smaller. Thus the system cost and panel space are significantly lower when Capacitor Duty Contactors are used.

MO C Capacitor Duty Contactors

MO C Capacitor Duty Contactors are designed for switching 3 phase, single or multi-step capacitor bank. In conventional capacitor switching contactors, early make auxiliary contacts used for insertion of damping resistors used to remain in the circuit continuously. During current breaking these auxiliary contacts would also carry and break the currents due to higher arc resistance in the main pole during arcing. This current breaking by auxiliary contacts at higher transient recovery voltage causes unreliable product performance and premature product failures.

MO C range of capacitor switching contactors have patented mechanism which disconnects the early make auxiliary contacts after the main contacts are closed. This completely eliminates the possibility of auxiliary contacts carrying and breaking the currents during breaking operation. This enhances the product switching performance and improves the product life.

Features and Benefits of MO C Capacitor Duty Contactors

Feature	Customer Benefits
De-latching auxiliary contacts	Improved switching performance
Dual contact gap for auxiliary contacts	Reduced losses in auxiliary contacts
Encapsulated resistor assembly	Higher electrical life
	Enhanced product safety
Separate termination of damping resistors	No flash over between phases
	Ease of wiring
Wide and chatter-free operating band and in-built surge suppressor	Enhanced operational reliability
	Improved switching performance
	Higher electrical life
	Higher product reliability

Ordering Information

Contactors

Product Designation	kVAr Rating @ 415V 50Hz	In Built Aux contacts	Cat. No.*
MO C3	3	1 NO	CS96146
MO C5	5	1 NO	CS96127
MO C8.5	8.5	1 NO	CS96320
MO C10	10	1 NO	CS96156
MO C12.5	12.5	1 NO	CS96321
MO C15	15	1 NO	CS90019
MO C20	20	1 NO	CS90021
MO C25	25	1 NO	CS96322
MO C30	30	1 NO	CS96148
MO C40	40	1 NO	CS96147
MO C50	50	1 NO	CS96324
MO C60	60	1 NO	CS96149
MO C75	75	1 NO	CS96150
MO C85	85	1 NO	CS96157
MO C100	100	1 NO	CS96158

*: Add four digit suffix as per coil voltage

Accessories & Spares

Add on Blocks

Mounting Position	Contacts	Cat. No.
First Left	1 NO + 1 NC	CS945800000
First Right	1 NO + 1 NC	CS945810000
Second Left	1 NO + 1 NC	CS945820000
Second Right	1 NO + 1 NC	CS945830000

Spare Coils

For Contactor	Cat. No.
MO C3 - C30	CS96317
MO C40 - 60	CS96318
MO C70 - 100	CS96319

* Add four digit suffix as per coil voltage

MO C Spreader Link Kit

For Contactor	Cat. No.
MO C3 - 30	CS942740000
MO C40 - 60	CS940930000
MO C75 - 100	CS940940000



Note: 1) Spreader Link Kit consists of six terminals
 2) Use above Spreader Link when using
 MO C 25 16 sq. mm cable

Ordering Suffix for Coil Voltages

Std Coil Voltage	110	220	240	415
Ordering Suffix - 50 Hz	A000	K000	B000	D000
Ordering Suffix - 60 Hz	Y000	V000	-	S000

Technical Specification

- Available for capacitor range from 3 - 100 kVAr
- Modular design saving precious panel space
- De-Latching auxiliary contacts
- Separate termination of damping resistors
- Encapsulated resistor assembly ensuring safety
- In-built surge suppressor with the coil
- Lugless termination



Type Designation				MO C3	MO C5	MO C8.5	MO C10	MO C12.5	
kVAr Rating (at System voltage 440 V) [#]		kVAr		3	5	9	10	13	
Catalogue No.	Built in Aux Contacts	1 NO		CS96146	CS96127	CS96320	CS96156	CS96321	
Conformance to Standards									
Rated Operational Current at 440 V, 50 Hz	I _e	A		3.9	6.6	11.2	13.1	16.4	
Short Circuit Protection									
Max. Operational Voltage	U _e	V		690	690	690	690	690	
Rated insulation Voltage	U _i	V		1000	1000	1000	1000	1000	
Rated Impulse Withstand Voltage	U _{imp}	kV		8	8	8	8	8	
Degree of Protection									
Main Terminal Capacity	Cable with Ferrule type lug								
	Cable with Pin type lug								
	Cable with Fork type lug								
	Cable with Ring type lug								
	Solid Conductor			mm ²	2 x 10	2 x 10	2 x 10	2 x 10	2 x 10
	Stranded Conductor			mm ²	2 x 10	2 x 10	2 x 10	2 x 10	2 x 10
	Finely Stranded Conductor			mm ²	2 x 6	2 x 6	2 x 6	2 x 6	2 x 6
Coil Operating Band	Pick-up	% U _c	V	65 - 110	65 - 110	65 - 110	65 - 110	65 - 110	
	Drop-off	% U _c	V	35 - 65	35 - 65	35 - 65	35 - 65	35 - 65	
Coil Consumption	Pick-up		VA	77	77	77	77	77	
			VA	9	9	9	9	9	
	Hold-on		W	3	3	3	3	3	
Life (Operating Cycles)		Mechanical	Million	10	10	10	10	10	
		Electrical	Million	0.2	0.2	0.2	0.2	0.2	
Max. Operating Frequency		Operations / Hr		240	240	240	240	240	
Operating Sequence	Making								
	Breaking								
Overall Dimensions	Height	H	mm	87	87	87	87	87	
	Width	W	mm	45	45	45	45	45	
	Depth	D	mm	133.5	133.5	133.5	133.5	133.5	
	Mounting Dimensions			mm	35x60-65-70	35x60-65-70	35x60-65-70	35x60-65-70	35x60-65-70

Note: Contact replacement is not permitted in MO C contactors

* Accessories and Spares same as that of MO contactor.

** Dimension is with the spreader link

kVAr ratings should be selected as per the net kVAr of the capacitor reactor combination irrespective of capacitor voltage (440V/480V/525V)

While selection it should be ensured that current rating of capacitor is less than the current through the contactor

\$ Use spreader while using 16 sq.mm cable

\$\$ Terminal capacity mentioned is with spreader



MO C15	MO C20	MO C25	MO C30	MO C40	MO C50	MO C60	MO C75	MO C85	MO C100
15	20	25	30	40	50	60	75	85	100
CS90019	CS90021	CS96322	CS96148	CS96147	CS96324	CS96149	CS96150	CS96160	CS96158
IS/IEC 60947-4-1, IEC 60947-4-1, EN 60947-4-1									
19.7	26.2	32.8	39.4	52.5	65.6	78.7	98.4	111.5	131
gG type fuses rated at 1.5-2 le									
690	690	690	690	690	690	690	690	690	690
1000	1000	1000	1000	1000	1000	1000	1000	1000	1000
8	8	8	8	8	8	8	8	8	8
IP20									
1 X (4 -10)									-
1 X (4 -10)									-
1 X (4 -10)									-
-									1 X (10 - 15)
2 x 10	2 x 10	2 x 10 ^S	2 x 16 ^{SS}	-	-	-	-	-	-
2 x 10	2 x 10	2 x 10 ^S	2 x 16 ^{SS}	2 x 35	2 x 35	2 x 35 ^{SS}	2 x 70	2 x 70	2 x 95 ^{SS}
2 x 6	2 x 6	2 x 6 ^S	2 x 16 ^{SS}	2 x 35	2 x 25	2 x 35 ^{SS}	2 x 50	2 x 50	2 x 95 ^{SS}
65 - 110	65 - 110	65 - 110	65 - 110	75 - 110	75 - 110	75-110	75 - 110	75 - 110	75 - 110
35 - 65	35 - 65	35 - 65	35 - 65	35 - 65	35 - 65	35 - 65	35 - 65	35 - 65	35 - 65
77	77	77	77	144	144	144	240	240	240
9	9	9	9	15	15	15	25	25	25
3	3	3	3	6	6	6	9	9	9
10	10	10	10	10	10	10	10	10	10
0.2	0.2	0.2	0.2	0.2	0.2	0.2	0.2	0.2	0.2
240	240	240	240	240	240	240	240	240	240
Early Make / Main									
Main Contacts Break									
87	87	87	115**	123.5	123.5	174**	135	135	195**
45	45	45	56**	55	55	73**	70	70	95**
133.5	133.5	133.5	133.5**	163	163	163**	175	175	175**
35x60-65-70	35x60-65-70	35x60-65-70	35x60-65-70	45x100-105	45x100-105	45x100-105	60x115-120	60x115-120	60x115-120

Dimension details MO C

kVAr	3	5	8.5	10	12.5	15	20	25	40	50	60	75	85
------	---	---	-----	----	------	----	----	----	----	----	----	----	----

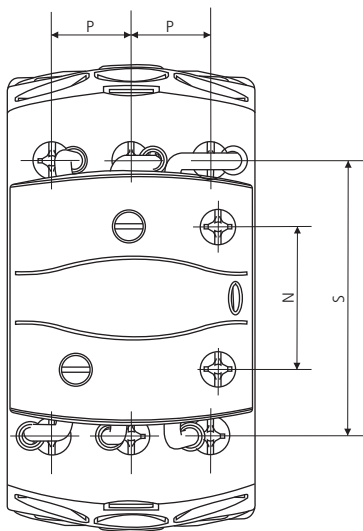
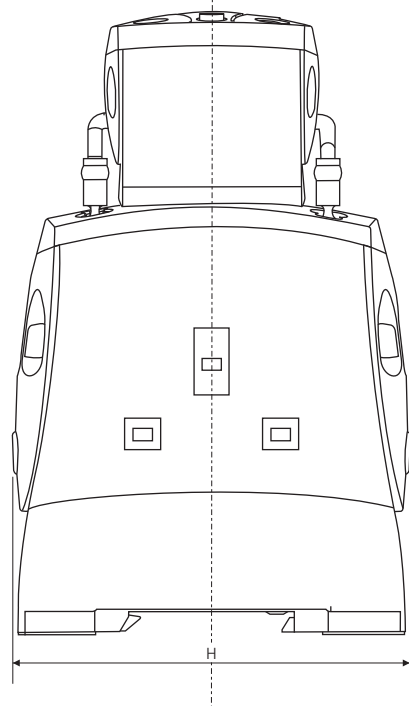
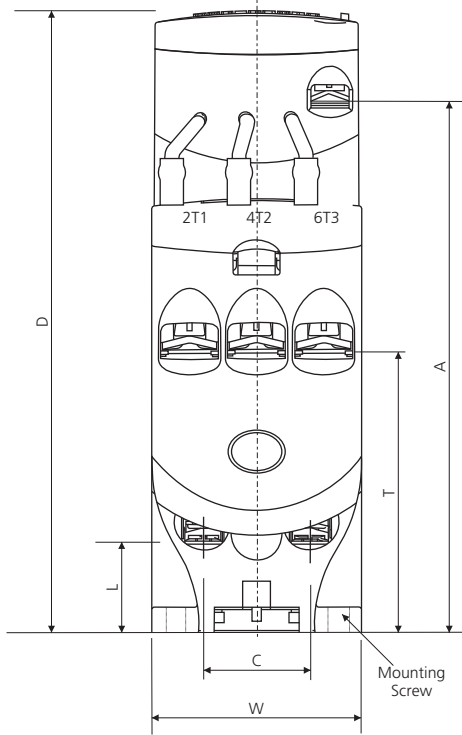

Label	MO C		
	3 - 25	40 - 50	75 - 85
W	45	55	70
D	133.5	163	175
H	87	123.5	135
N	26	26	26
T	60	68	68
C	22.8	27	35
L	19.6	29.5	30
S	50	82	93
P	14.4	18	23
A	113	142	154

All dimensions in mm.

MO C Frame 1 (with spreader links) / MO C 30

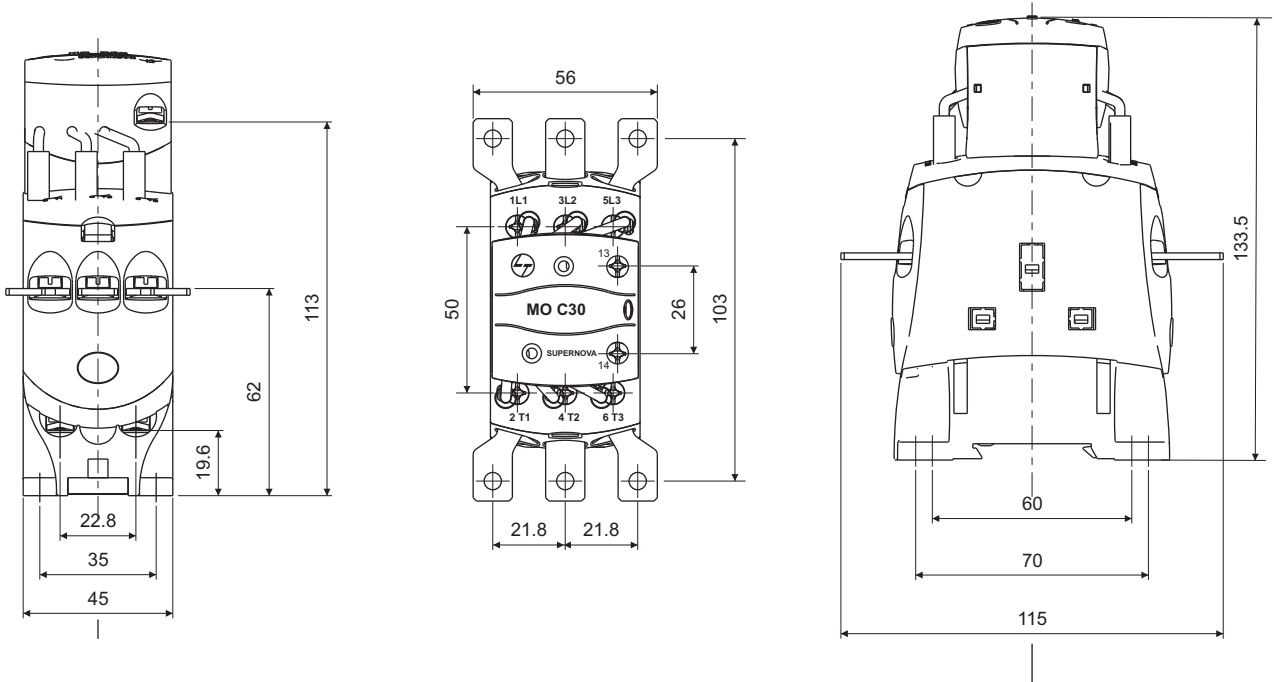

MO C Frame 2 (with spreader links) / MO C 60

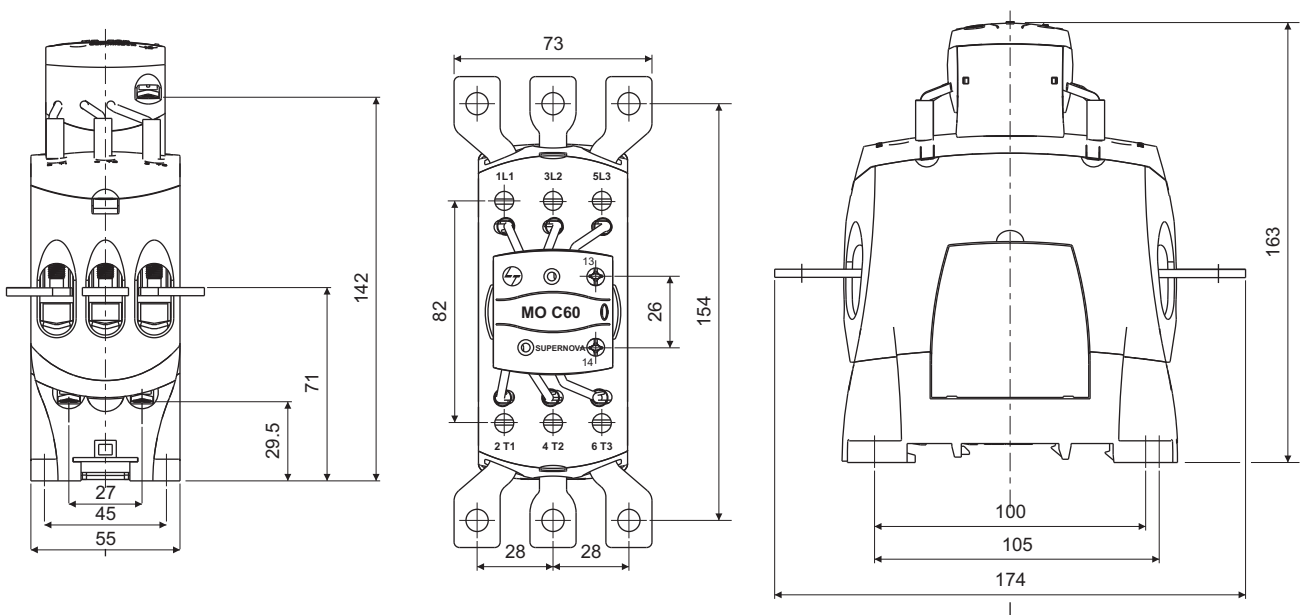

MO C Frame 3 (with spreader links) / MO C 100

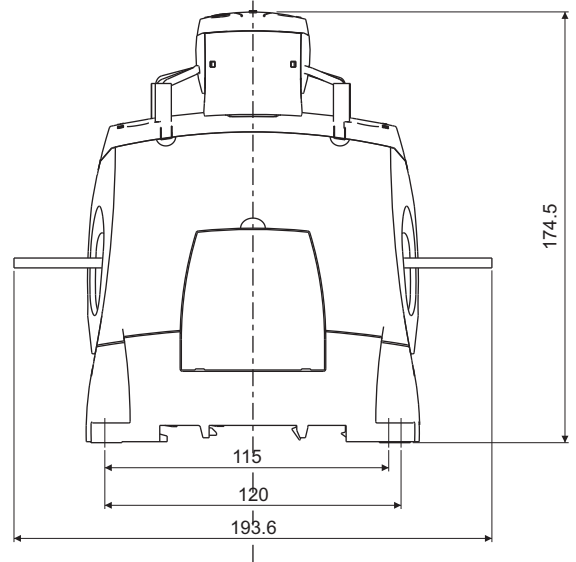
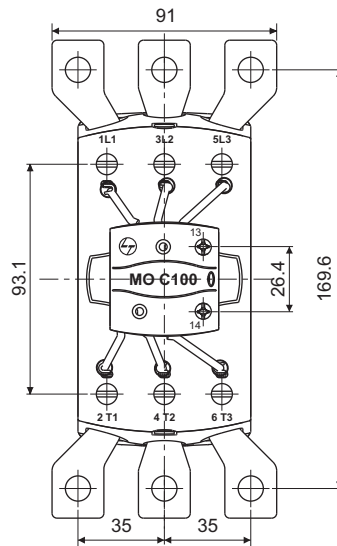
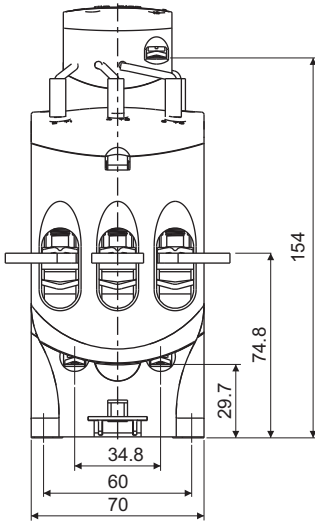

Conventionally, power factor correction systems consist of power factor correction capacitors switched using capacitor duty contactors. The re-switching time is the sum of capacitor discharge time (within 75 seconds as per IEC 60831) and response time of contactor. Such arrangement is suitable for applications where few switching operations take place per day.

Many applications increasingly require real-time reactive compensation. With this, the demand for dynamic power factor correction arises and faster switching of capacitors becomes inevitable.

This section discusses the need for thyristor switching module and the care to be taken while designing systems with thyristor switching modules.

Need for Dynamic Power Factor Correction

Faster response is needed when the demand for reactive power is rapidly fluctuating either due to rapidly changing load conditions or process requirements. For certain loads, like,

- Welding equipment
- Injection moulding equipment
- Industrial presses
- Loads such as, lifting cranes, elevators, lifts etc.

the demand for reactive power comes frequently and for short duration of time.

Large reactive power demand for very short durations has severe ill-effects, such as:

- Rapid fluctuations in voltage which may lead to system instability
- High voltage transients may result in insulation breakdown or damage to other loads
- Malfunctioning of sensitive electrical and electronic equipment such as relays, PLCs
- Oversizing of electrical installation is needed since kVA capacity needs to be provided for maximum power demand

Why Not Contactors?

Contactors are electro-mechanical devices which switch capacitors after a lag. Also, due to discharge time of capacitors, the re-switching time of contactors becomes longer than 60 seconds. This makes contactor a slow device.

In-rush current in capacitor switching are reduced to 10 times the rated current if capacitor duty contactors are used. However, a certain pulse element is inevitable as can be seen in Figure 1.

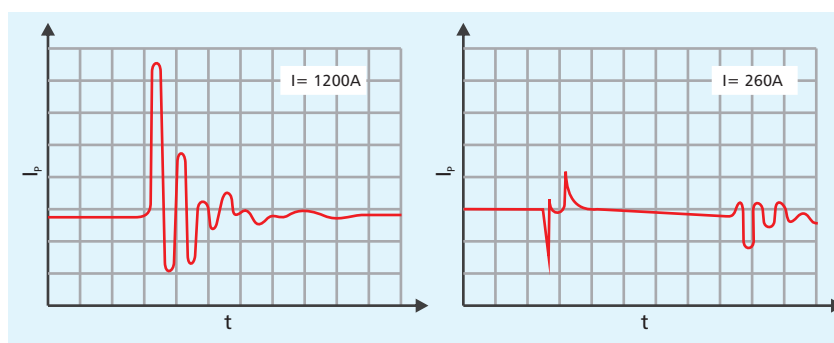

Figure 1 : Transient during capacitor switching by a) Normal contactor b) Capacitor-duty contactor

Inrush current occurrences cause high electromechanical forces within the capacitor. The dielectric inside the capacitor is highly stressed due to this high current. This could lead to reduction in the life of capacitors.

In order to obviate the above shortfalls, the thyristor switching modules are used.

Principle of Operation of TSM

A thyristor switching module (TSM) is a fast, electronically controlled thyristor switch for switching capacitor loads within a few milliseconds as often and as long as required.

First of all, being a thyristor-based switch, the thyristor switches the capacitor without delay. A thyristor switching module works on the principle of zero-voltage switching, i.e., the capacitor is switched ON only when the voltage waveform is at its zero crossing. The current through a capacitor is given by:

$$I_c = C \frac{dV_c}{dt}$$

Where, I_c is capacitor current, C is capacitance and V_c is voltage across capacitor. This current is directly proportional to the rate of change of voltage across the capacitor. Thus, when capacitors are switched ON at zero crossing of supply voltage, the voltage applied to the capacitor is almost zero and grows steadily following the sine wave. Thus, the inrush current becomes equal to the rated current.

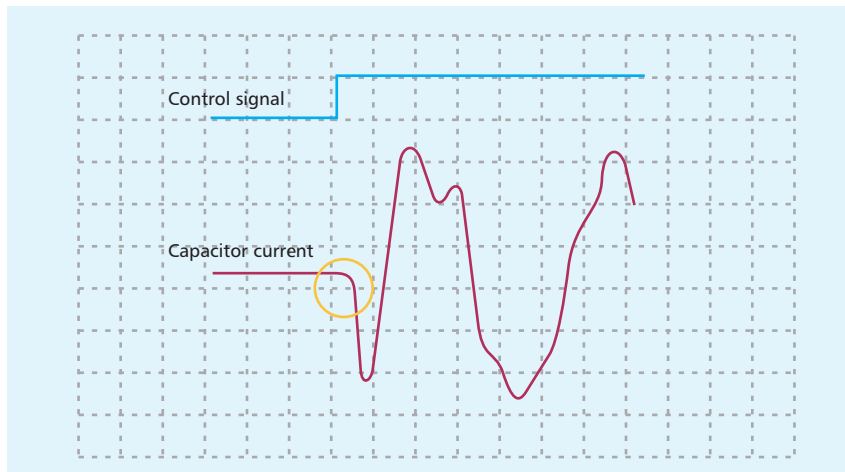

Figure 2 : Zero in-rush current during capacitor switching by TSM

Importance of QDR

Another point to be noted here is that the capacitors used with TSM should be fitted with quick discharge resistors (QDR). If the capacitors are used with the usual discharge resistors, then, the capacitor may not get fully discharged at the time of re-switching. In such a situation, there will still be a significant voltage across the capacitor resulting in high inrush current. Quick discharge resistors ensure that the capacitor is completely discharged before its re-switching. The typical discharge time of normal resistors is to reach less than 50 V within 60 seconds. However, for QDR, the discharge time is reduced significantly so that there is a higher probability of switching at zero crossover, making the capacitors suitable to be used with thyristor switching modules.

PIV Rating of TSM

The typical arrangement of thyristor switches in a thyristor switching module is given in figure 3. Two terminals of a delta connected-capacitor are connected to the line via TSM while the third is connected directly to the line (all three phases have high speed fuses for branch protection). This configuration obviates the need to use three switch-pairs while ensuring that the three-phase capacitor is connected only when both switch pairs are ON or the module is ON. Each switches pair is a combination of two thyristors connected in anti-parallel for operation with ac voltage.

Peak Inverse Voltage (PIV) rating of a thyristor switch is the maximum peak voltage that the thyristor can withstand in the reverse biased condition. It is the maximum voltage that it must block when it is in OFF condition. A module with thyristors of lower PIV, say 1600 V, is likely to fail in presence high voltage surges. Hence, higher values of PIV are desirable. Typically, in capacitor switching applications, the PIV ratings are up to 2200 V.

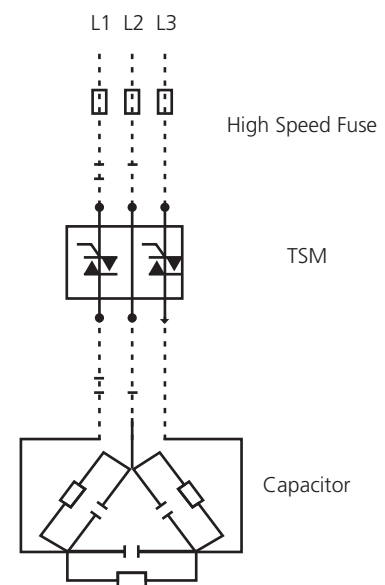

Figure 3 Arrangement of thyristor in a TSM

Advantages of TSM

- Faster switching of capacitors with response time from 5-40 ms can be achieved.
- No delay due to capacitor discharge
- No inrush current ensures that there are no resulting voltage fluctuations or transients. Thus, we get transient-free smooth switching and stable voltage and increased life of capacitors
- No arcing owing to a static switch
- Thyristor switches allow any number of switching operations as they are not subjected to any mechanical wear. Thus, a longer service life as compared to contactors
- With dynamic compensation, reactive power is more efficiently compensated resulting in further lowering of energy costs
- With reduced peak of inrush current, cables and equipment used can be of smaller short circuit rating reducing capital expenditure

High Speed Fuse for Branch Protection

For short circuit protection of a thyristor switching module, a faster protection device is needed so that it will act before the thyristor switch in case of a short circuit. Normally, an HRC fuse has a time characteristics based on the I^2t characteristics of cables as per IEC 60269-2. In case of a short circuit, the thyristor will blow before the fuse. However, a semiconductor back-up (or a high speed) fuse has a time characteristics based on I^2t characteristics of a thyristor. Hence, semiconductor fuse or high speed fuse can protect the thyristor module.

Forced cooling for TSM

Being electronic switches, the heat generated due to losses needs to be dissipated quickly. The thyristor switching modules are generally designed with fins for better heat dissipation. They should be mounted in a position so that maximum air flow is possible. Additionally, it is always recommended to use an adequately-sized fan in the compartment where TSMs are mounted in an APFC panel.

Some thyristor switching modules come with in-built fans for cooling. Practically, it is difficult to spot a fan failure in such a case and an undetected fan failure may lead to failure of TSM. The TSM module becomes unnecessarily bulky in such cases. Hence, it is best to use fan-less modules with an adequately-sized fan on panel ceiling.

How to Connect

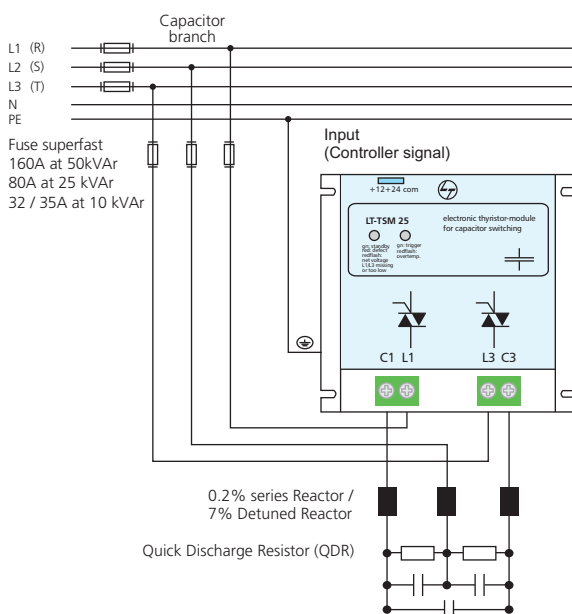

Figure 4 Connection Diagram of TSM

A TSM is connected to the line via a semiconductor fuse and its output is given to the three-phase capacitor or a detuned filter (in case harmonics are present). Triggering of a TSM can be done by means of dynamic power factor controllers. Triggering can be done by a controller which has a transistor output. Typically, a TSM has a 24 V or/and a 12 V input and the respective currents required for triggering are approximately 15 mA and 20 mA respectively. Sometimes, more than one TSM is required to be connected to the same controller output for making a larger step, say, 100 kVAr. In such a case, more than one TSM can be connected to one output of the controller. The maximum number of TSMs that can be connected to a controller is restricted by the dc supply available and the maximum current limit of a stage output of the controller output.

Another point to be noted here is that in case of TSM, there is no electrical isolation. Due to the switching principle of the thyristor-modules the PFC-capacitors are permanently loaded at the peak value of the grid voltage (DC current) even when they are disconnected. Even when the thyristor switches are off, no electrical isolation is given. Hence, even after switching off the in-comer of the APFC system, parts should only be touched after the standard discharge time of the capacitors.

Combination of Contactor-based & Thyristor-based Panels

Thyristor switching modules being expensive is often a concern for industry. An economical solution without compromising the performance of power factor correction panel can still be devised in many applications. Typically, an industry consists of a variety of loads – some fixed loads that are always running, some varying motor loads that run for some part of the day and some highly fluctuating loads.

The following solution is suggested:

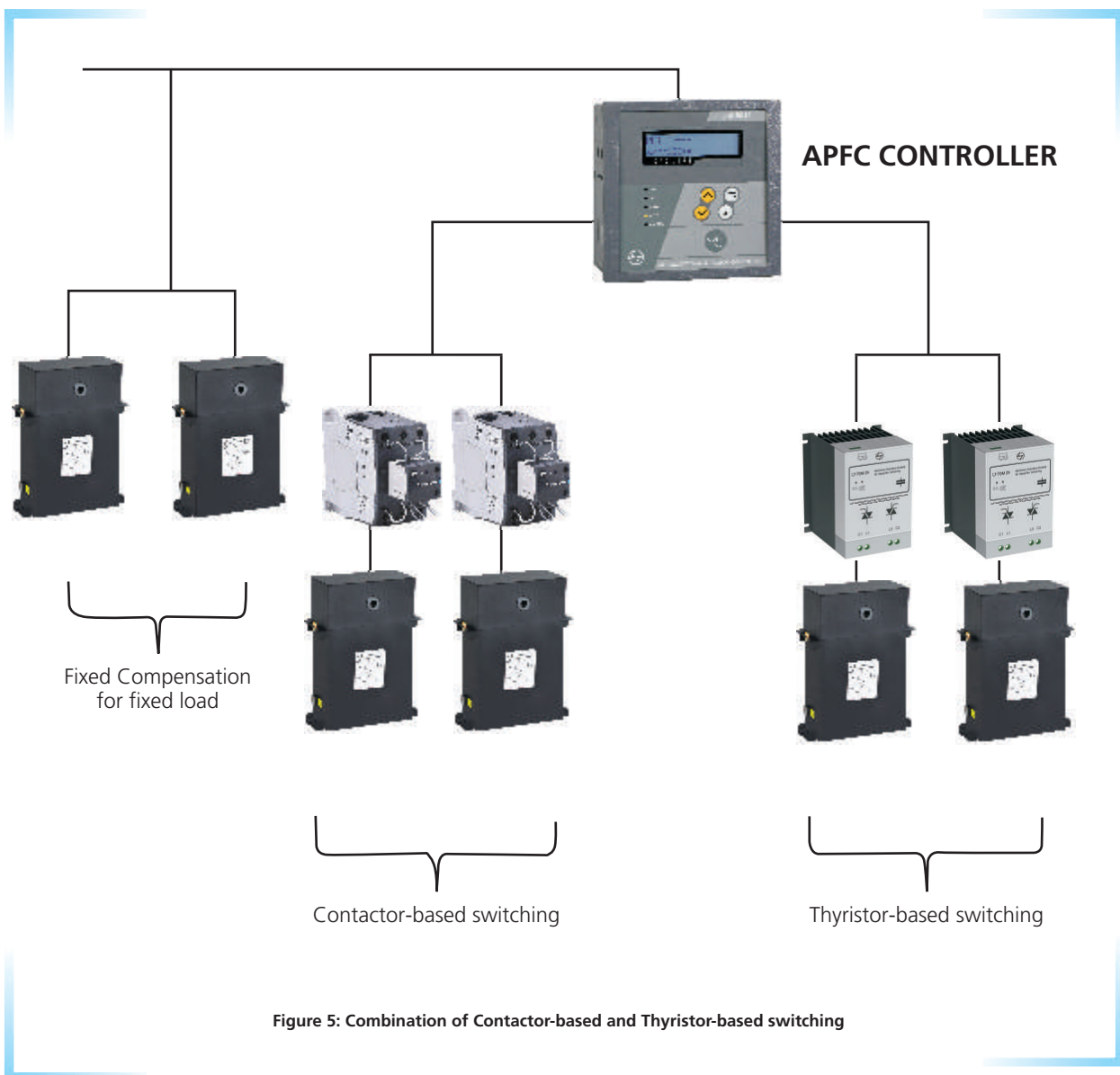

Figure 5: Combination of Contactor-based and Thyristor-based switching

The most economical solution can be to provide some fixed capacitors for the loads that are ON throughout the day, a contactor-based switching for capacitors providing compensation to varying motor loads and a thyristor-based switching for capacitors providing compensation to highly fluctuating loads.

In some modern industries, due to special processes with rapidly fluctuating loads, the demand for reactive power also fluctuates rapidly. Usage of mechanical switch (contactors) has the following negative impacts:

- Average unity power factor cannot be maintained due to delay in capacitor switching
- Reduction in the life of capacitors, contactors and other equipments
- Power quality issues due to current and voltage transients

The solution is dynamic power factor correction system.



With the thyristor module we provide the main component - "The Electronic Switch"- for dynamic power factor correction. The LT-TSM series offers fast electronically controlled, self-observing thyristor switches for capacitive loads up to 50 kVAR, that are capable to switch PFC capacitors within a few milliseconds nearly without a limitation to the number of switchings during the capacitor lifetime. These switching modules are easy to install, have a fast reaction time of 5 msec and come with built-in indications of operations, faults and activation. These thyristor modules are very compact and operate at lower power losses.

Features

- High peak inverse voltage (2.2 kV) ensures long operational life
- Automatic thermal cut-off
- Monitoring of voltage, phase sequence, faults and display of status via LED
- Faster response time - 5 ms
- No system perturbation caused by switching operations (no transients)
- No auxiliary supply needed
- Maintenance free
- Long operational life
- High switching speed
- No noise during switching
- Compact design ready for connection and easy installation

Application

Industries and applications with high load fluctuations, where the demand for reactive power is also very dynamic:

- Welding
- Elevators and cranes
- Presses
- Wind turbines

Technical Details

	LT TSM 10	LT TSM 25	LT TSM 50
Rated Voltage (V)	440 V		
Frequency (Hz)	50 / 60		
Rating (kVAr)	10	25	50
Power Losses (W)	35	75	150
LED Display Per Phase	2	2	2
Ambient Temperature (°C)	-10 to 55		
Signal Voltage Required	10-24 Vdc (20 mA)		
Peak Inverse Voltage (PIV)	2.2 kV		
Reaction Time	5 ms		
Re-switching Time	60 ms		
Indication / Display	<p>LED - Left side Green: Operating voltage activated, thyristor module standby Red permanent: Capacitor without capacitance or not existant; thyristor or fuse defect Red flashing: net voltage L1/L3 missing or too low</p> <p>LED - Right side: Green: "Module ON" (Trigger) Red flashing: Over-temperature</p>		
Monitoring	Permanent monitoring of net voltage, temperature and operation status (Note: Before re-switching after temperature fault, heat sink temperature must be below 50°C)		
Termination	Connection from bottom; Cable lug: 25 sq. mm. D: 8 mm		
Protection	Semiconductor fuse (High speed fuse) is mandatory for short circuit protection.		
	10 kVAr : 32 A	25 kVAr : 80 A	50 kVAr : 160 A
Capacitor Discharge Resistor	Quick discharge resistors (Default capacitor discharge resistors shall be interchanged with QDR)		
Mounting Position	Vertical, minimum 100 mm space clearance around the module		

Selection of TSM and Semiconductor Fuse

Capacitor Step (kVAr)	Rated Current (A)	TSM Rating (kVAr)	Semi-conductor fuse rating (A)
5	6.6	10	16
10	13.1	10	32
12.5	16.4	25	40
15	19.7	25	48
20	26.2	25	64
25	32.8	25	80
30	39.4	50	96
35	45.9	50	112
40	52.5	50	128
50	65.6	50	160
75	98.4	3 nos. of 25	3 nos. of 80 A
100	131.2	2 nos. of 50	2 nos. of 160 A

Network of Thyristor Switching Modules

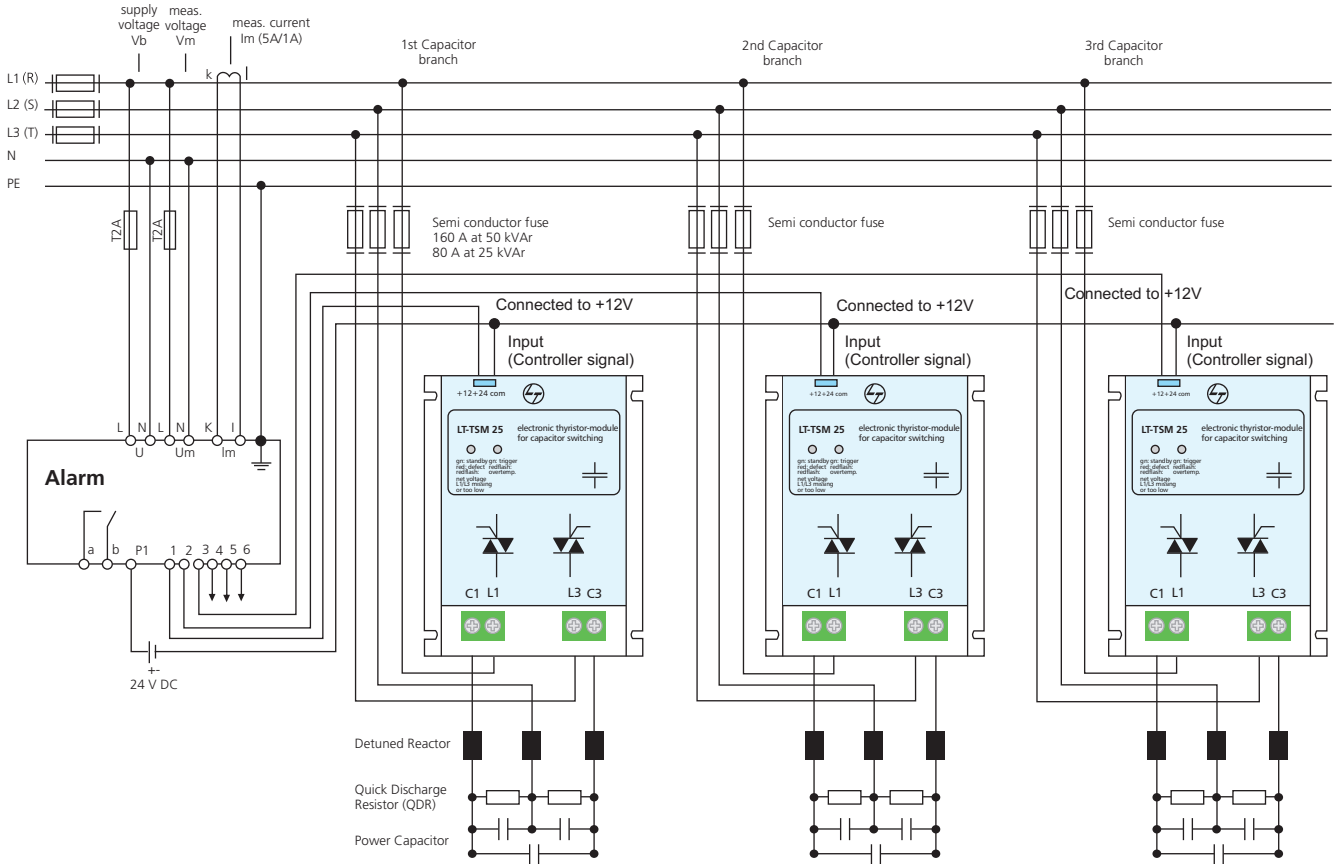

Application:

Connection of more than 1 LTTSM at each output of the Controller

- Connection of 2 LTTSM: use the 24V input - current will be approx. 15mA
- Connection of 2 LTTSM: use the 12V inputs in series - current will be approx. 20mA
- Connection of 4 LTTSM: use 2 x 2 LTTSM in parallel and in series (see pic. above) - current will be approx. 40mA

Thyristor Switching Modules - Dimensions

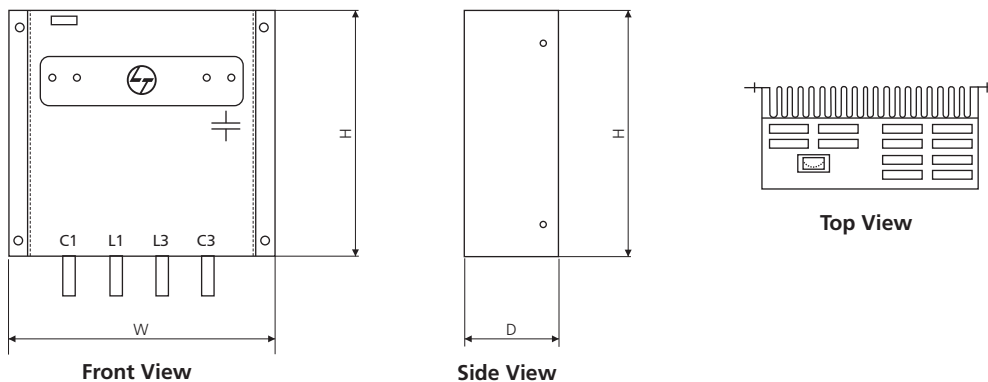

Rating (kVAr)	Max. RMS Current (A)	Dimensions in (mm)			Cat. Nos.
		W	D	H	
10	20	153	75	153	LTTSM10B2
25	50	157	175	200	LTTSM25B2
50	100	157	175	200	LTTSM50B2



etaULTRA



etaULTRA APFC Controller automatically corrects the power factor with the help of either contactors or thyristors for connection and disconnection of capacitors. It has specially formulated optimization program in microcontroller which ensures accurate power factor control at set point and hunt free operation.

etaULTRA Hybrid APFC Controller can be used for a combination of both Contactor Switched Varying Motor Loads & Thyristor Switched Fast Fluctuating Loads. Hence Bigger Steps of the order of 100 & 50 kVAR can be Contactor Switched & Thyristor Switched Smaller Steps can be used for fine tuning of Power Factor.

The etaULTRA series can be cascaded in Master-Slave configuration to increase contact output upto 64 steps. etaULTRA has inbuilt RS-485 Modbus Communication Protocol. There is a provision for dual PF Setting for Mains & DG Application. Individual harmonics can be measured upto 31st order & the PF Setting can be done upto 3rd digit after decimal. Moreover Current angles & Voltage angles can be displayed for the ease of troubleshooting..

Salient Features



MANUAL & AUTOMATIC OPERATION

- In auto mode, just initiate AUTO PROGRAM and the controller will configure itself or we can also configure it manually with few simple steps.



CONTROL MODE

- Option of LIFO, FIFO, and Intelligent control mode. Choose any of these control modes. By default, it is set as intelligent; this mode selects the best combination of capacitor bank for compensation with minimum switching to achieve the desired power factor.



POWER QUALITY INFORMATION

- Instant information on the quality of your power system. etaULTRA measures current THD, and alerts you if levels go beyond set limits.



CAPACITOR HEALTH CHECK

- Capacitor health check monitoring function ensures that capacitor is declared faulty if its power falls beyond a certain limit.



RECORD OF STEP-SWITCHING

- You can schedule the maintenance of your installation by reading the record of the number of switching of each step.



AMBIENT TEMPERATURE MONITORING

- Ambient Temperature Monitoring via Internal Sensor.

Timestamping



- The latest 32 alarms are recorded with their respective date & time.

Technical Specifications

Parameter	etaULTRA Series Automatic Power Factor Controller
No. of steps	8R, 16R, 8T+2R ,14T+2R, 8R + 8T
Current Measurement	Three Phase
Current input	1A / 5A
Aux. Supply	85-300VAC
Voltage input (L-L)	50 - 760 VAC/DC
Rated Frequency	50-60 Hz
Output contact rating	Relay,250 VAC@ 5 A
Display parameters	System PF, V, I, Required KVA _r , Voltage angles, Current angles, KVA, KW, KVA _r , V-THD, I-THD, Hz, Individual harmonics up to 31st order, Temperature.
Record parameters	Weekly avg. PF, Min/Max V, Max I, Max KVA/KW/KVA _r , Max V-THD, Max I-THD, Max Temperature.
Control Range Power	0.3 Lag to 0.3 Lead
Control Mode	Intelligent mode, LIFO, FIFO
Operation Mode	Automatic, Manual
Communication Interface	Modbus RTU (RS 485)
Cascading	Up to 64 step
Dual PF setting	Target PF 1 - Default, Target PF 2 - Based on Digital input
Digital Input	2 Digital Inputs, Programmable Range : 65-285VAC.
Alarms	Over / Under compensation, Over / Under voltage, Over / Under Current, High V-THD, High I-THD, Over / Under frequency, Over temperature, Modbus fail alarm, Capacitor fault alarm.
Power consumption	5.0 VA
Operating temperature	-20 to +60 °C
Relative humidity	< 90 %
Mounting	Flush
Degree of protection	IP20 (Front IP54)
Compliance	EN 61010 - 1, IEC/EN 61000-6-2, IEC/EN 61000-6-4, EN 61326

Wiring Diagrams

etaULTRA 8T + 2R / etaULTRA 14T + 2R

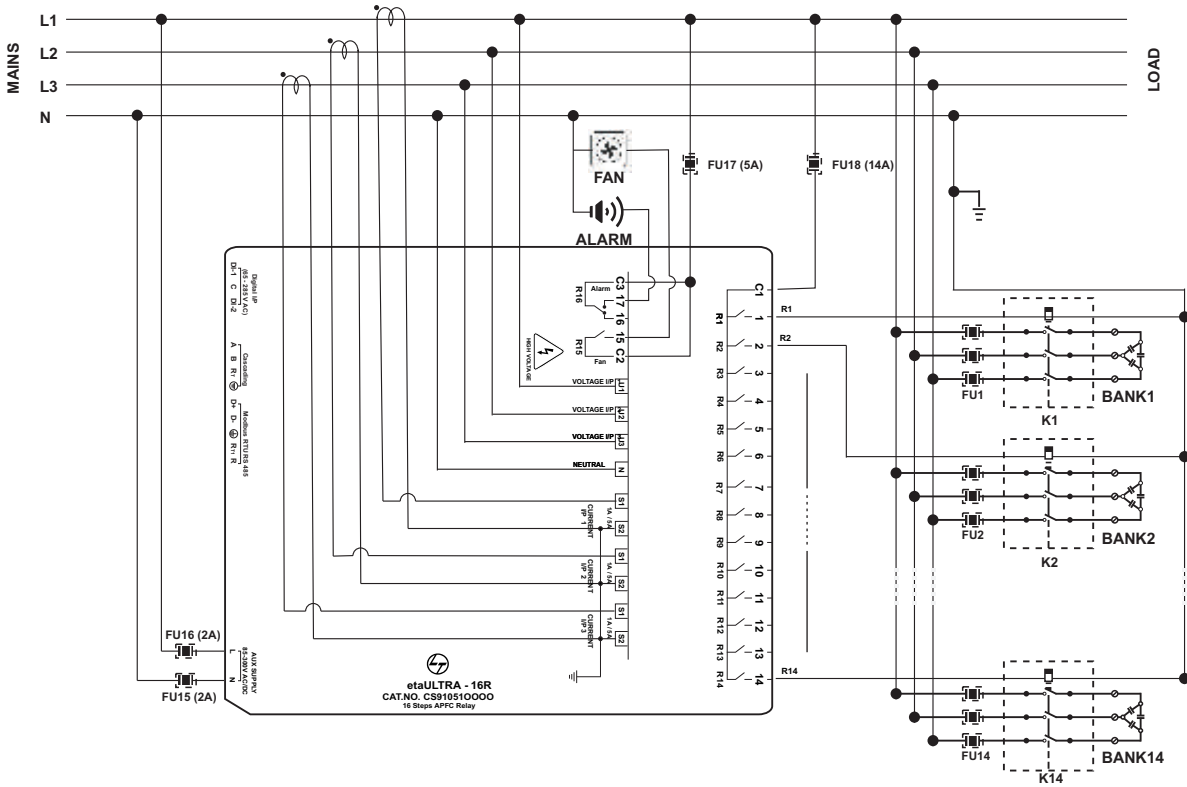

etaULTRA 8R + 8T

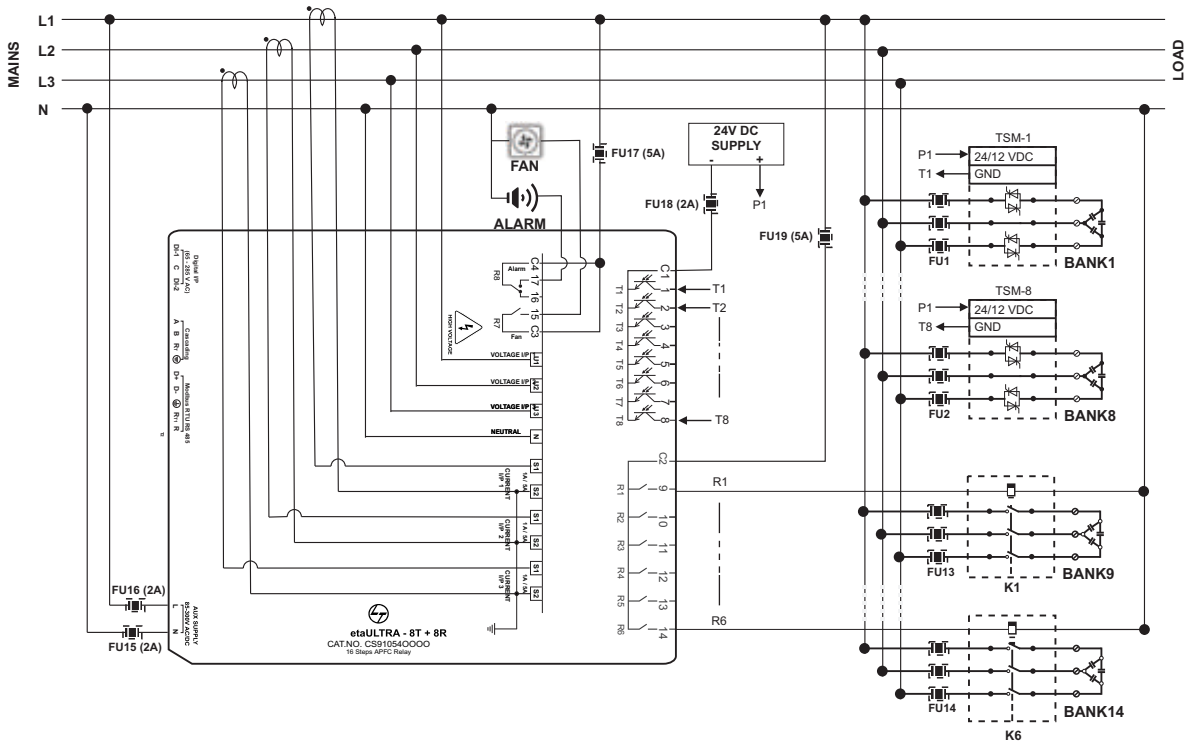

NOTE:

1. Last two relay output contacts can be configured either to switch the capacitor bank or to energise FAN and ALARM respectively as shown in wiring diagram.
2. All relay terminals, Voltage & current input terminals are suitable for wire range 12-30 AWG stranded or Solid copper wire. Modbus and cascading terminals are suitable for 14-30 AWG

Overall Dimensions

etaULTRA 8R, 16R, 8T+2R, 14T+2R & 8R+8T

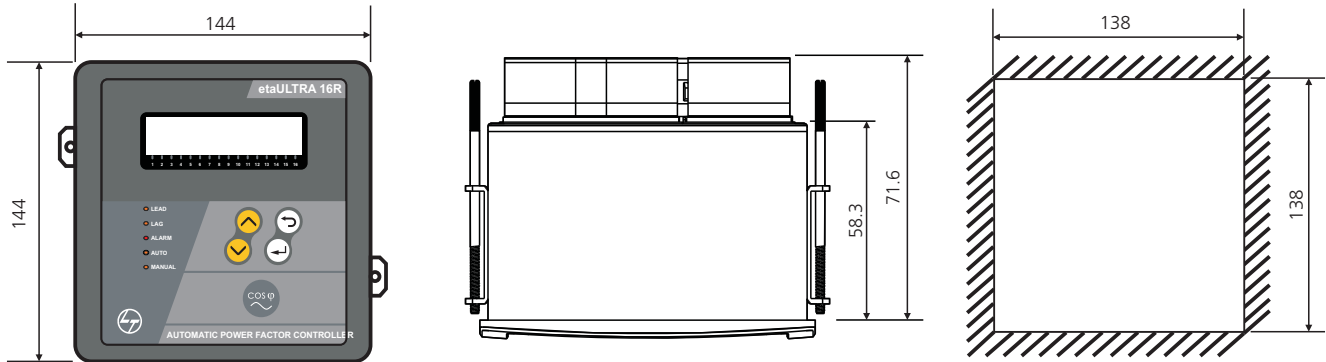

etaULTRA series – APFC Relay Selection Guideline

etaULTRA R – APFC Controller for Contactor switching with 3 CT Inputs

No. of Steps (For Contactor Switching)	Relay	Voltage Input	Size	Cat No.
3, 4, 5, 6, 7, 8	etaULTRA 8R	110/415	144 x 144	CS910500000
9, 10, 11, 12, 13, 14, 15, 16	etaULTRA 16R			CS910510000

etaULTRA T – APFC Controller for Thyristor switching with 3 CT Inputs

No. of Steps (For thyristor Switching)	Relay	Voltage Input	Size	Cat No.
3, 4, 5, 6, 7, 8	etaULTRA 8T+2R#	110/415	144 x 144	CS910520000
9, 10, 11, 12, 13, 14	etaULTRA 14T+2R#			CS910530000

2R# - These 2 relay contacts can either be configured for Thyristor control or to energise FAN & ALARM respectively.

etaULTRA 8R + 8T – Hybrid APFC Controller with 3 CT Inputs

No. of Steps (For Contactor Switching)	No. of Steps (For thyristor Switching)	Relay	Voltage Input	Size	Cat No.
1, 2, 3, 4, 5, 6, 7, 8	1, 2, 3, 4, 5, 6, 7, 8	etaULTRA 8R + 8T	110/415	144 x 144	CS910540000

etaSMART



etaSMART APFC controller automatically corrects the power factor with the help of contactors & thyristors for connection and disconnection of capacitors. It has a compact design with specially formulated optimization program in microcontroller which ensures accurate power factor control at set point and hunt free operation.

The etaSMART series is compact in design. It is available in two frame sizes & has 6 variants in relay contact outputs & 4 variants in transistor contact outputs.

Frame 1: 4R, 6R, 8R, 6T : 96mm x 96mm

Frame 2: 12R, 14R, 16R, 8T, 12T, 15T : 144mm x 144mm

The maximum step sizes available in etaSMART series is 16.

Salient Features



MANUAL & AUTOMATIC OPERATION

- In auto mode, just initiate AUTO PROGRAM and the controller will configure itself or we can also configure it manually with few simple steps



CONTROL MODE

- Option of LIFO, FIFO, and Intelligent control mode. Choose any of these control modes. By default, it is set as Intelligent; this mode selects the best combination of capacitor bank for compensation with minimum switching to achieve the desired power factor



POWER QUALITY INFORMATION

- Instant information on the quality of your power system. etaSMART measures current THD and voltage THD, and alerts you if levels go beyond set limits.



CAPACITOR HEALTH CHECK

- Capacitor health check monitoring function ensures that capacitor is declared faulty if its power falls beyond a certain limit.



RECORD OF STEP-SWITCHING

- You can schedule the maintenance of your installation by reading the record of the number of switching of each step



AMBIENT TEMPERATURE MONITORING

- Ambient temperature monitoring via internal sensor

RELAY OUTPUT CONFIGURATION

- Last relay output contact can be configured as Step or Alarm. Second-last relay output can be configured as Step or Fan control.

Technical Specifications

Parameters	etaSMART Series Automatic Power Factor Controller
No. of steps	4R, 6R, 8R, 12R, 14R, 16R, 6T, 8T, 12T, 15T
Current input	1A / 5A
Voltage input	415 - 440 VAC
Rated Frequency	50-60 Hz
Display parameters	PF, V, I, Required KVA _r , KVA, KW, KVA _r , V-THD, I-THD, Hz, Temperature
Record parameters	Min/Max V, Max A, Max KVA/KW/KVA _r , Max V-THD, Max I-THD, Max Temperature, Active Alarm
Control Range	Power factor range - 0.3 Lag to 0.3 Lead
Control Mode	Intelligent mode, LIFO, FIFO
Operation Mode	Automatic, Manual
Alarms	Over / Under compensation, Over / Under voltage, Over / Under Current, High V-THD, High I-THD, Over / Under frequency, Over temperature, No-volt release, Capacitor Faulty Alarm
Power consumption	7.5 VA
Operating temperature	-20 to +60 °C
Relative humidity	< 90 %
Mounting	Flush
Degree of protection	IP20 (Front IP54)
Compliances	EN 61010 - 1, IEC/EN 61000-6-2, IEC/EN 61000-6-4, EN 61326

Wiring Diagrams

etaSMART 4R / 6R / 8R

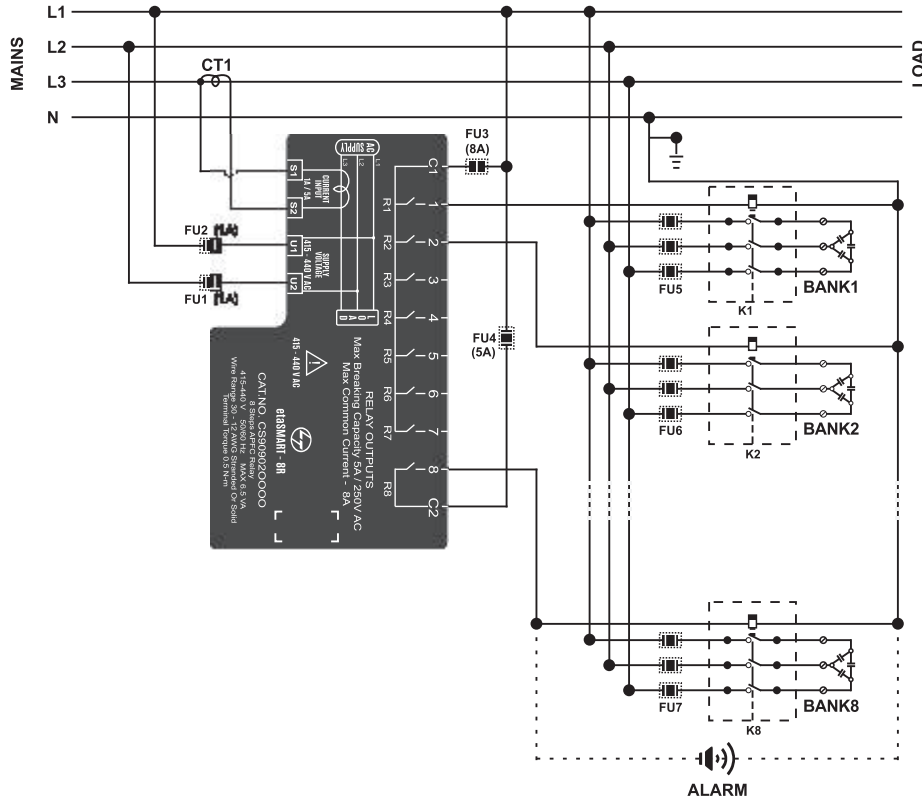

etaSMART 12R / etaSMART 14R / etaSMART 16R

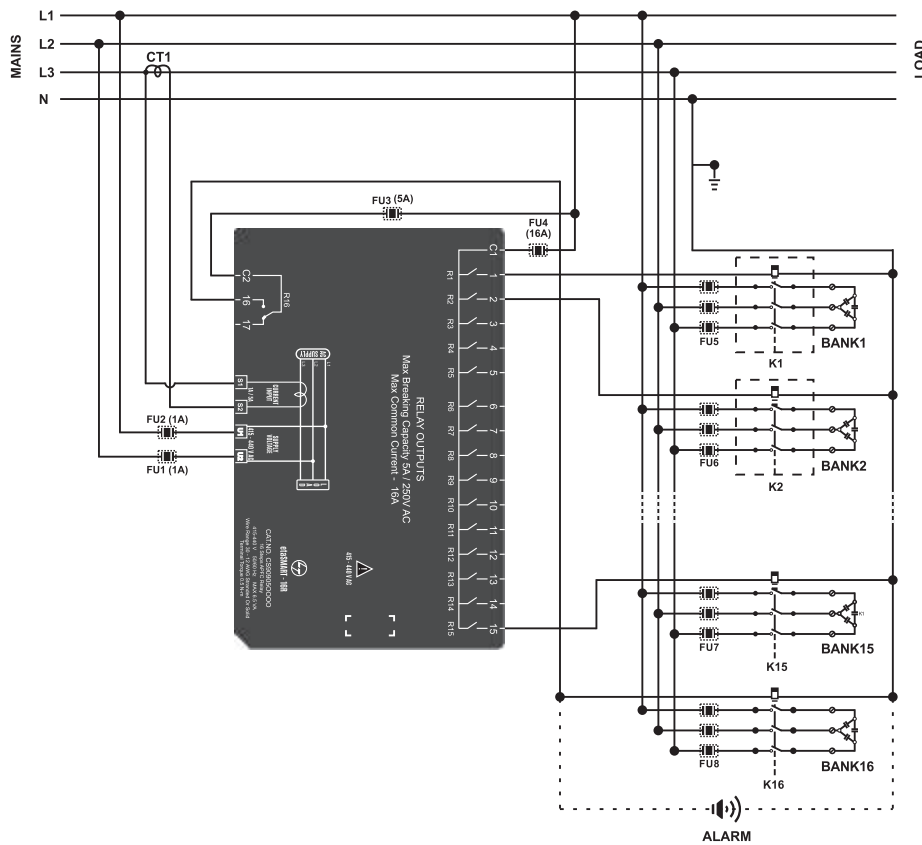

etaSMART 4R / 6R / 8R

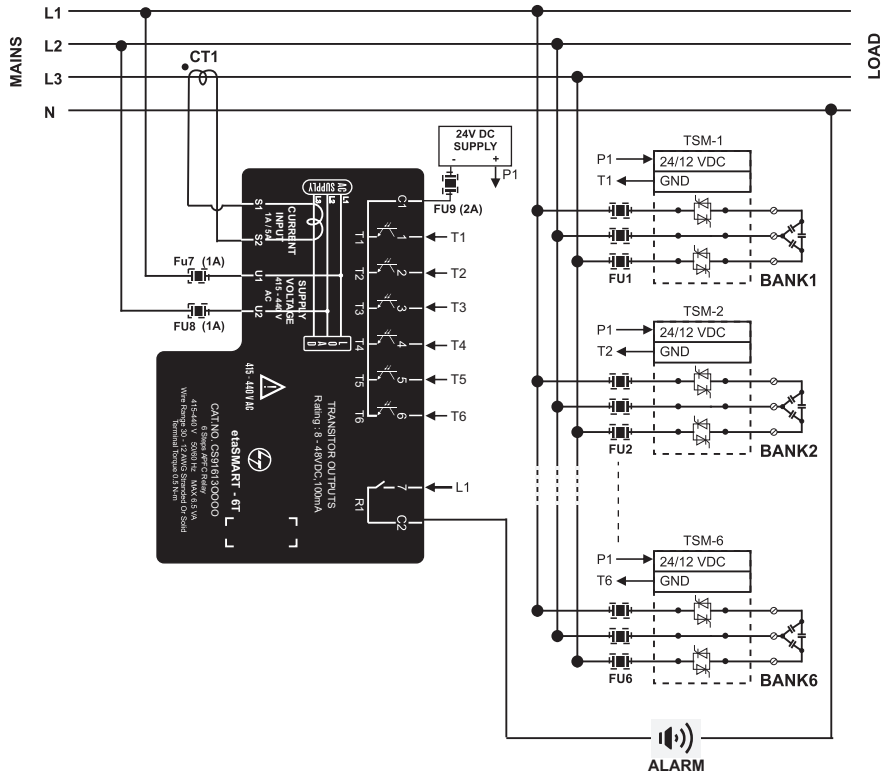

etaSMART 8T / 12T / 15T

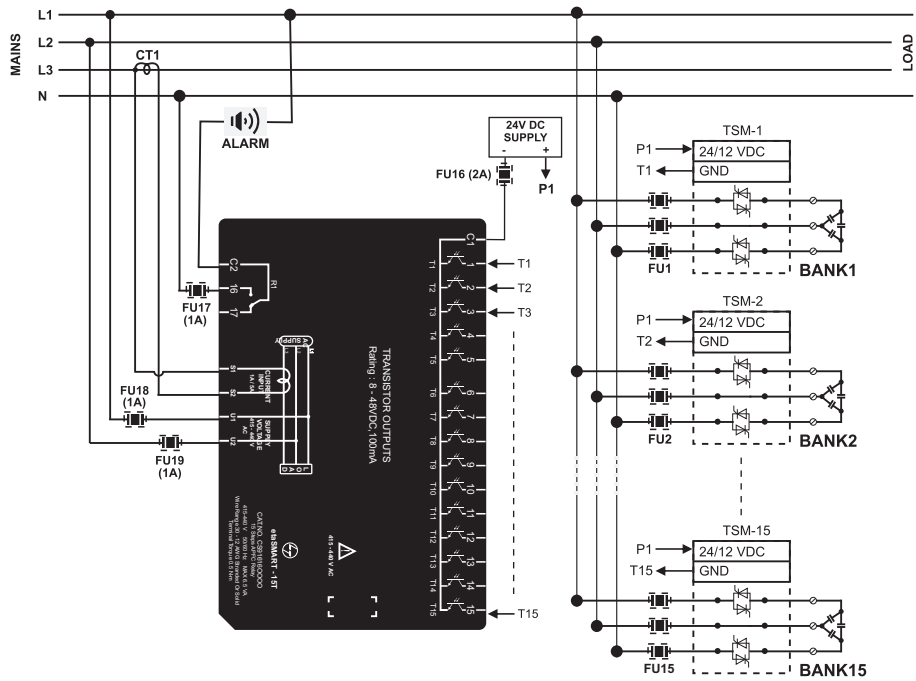

Overall Dimensions

etaSMART 4R, 6R, 8R & 6T Steps

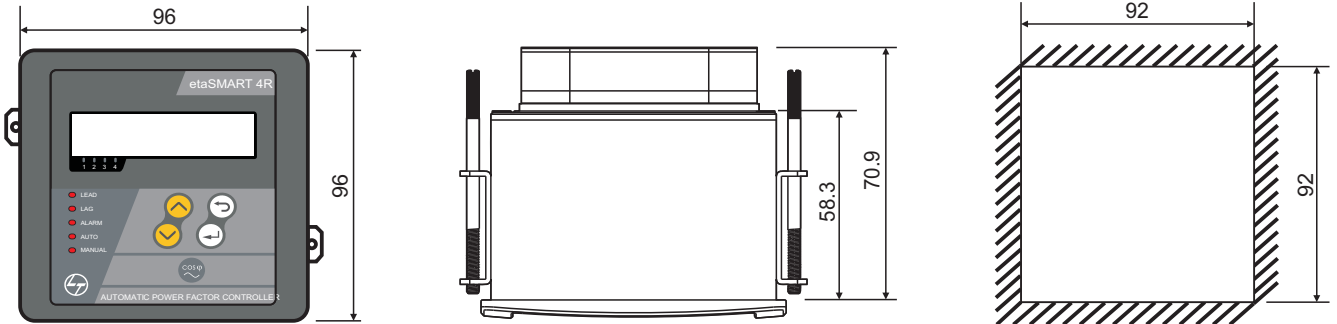

etaSMART 12R, 14R, 16R, 8T, 12T & 15T Steps

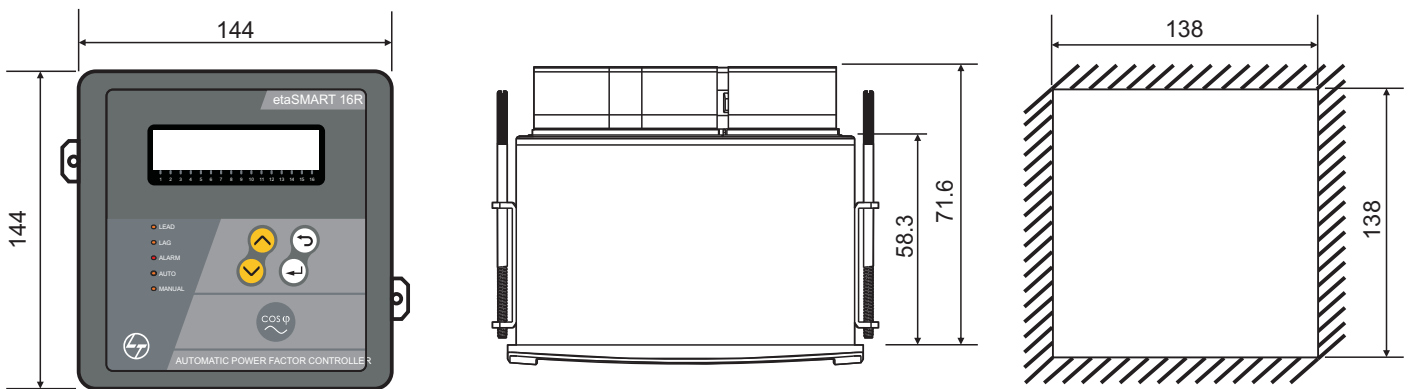

Dimensions are in mm

etaSMART series - APFC Relay Selection Guideline

Output	Steps	Relay	Size	Cat no.
Relay Contact Output	3,4	etaSMART 4R	96 x 96	CS908840000
	5,6	etaSMART 6R	96 x 96	CS908850000
	7,8	etaSMART 8R	96 x 96	CS909020000
	9,10,11,12	etaSMART 12R	144 x 144	CS909030000
	13,14	etaSMART 14R	144 x 144	CS909040000
	15,16	etaSMART 16R	144 x 144	CS909050000
Transistor Contact Output	3,4,5,6	etaSMART 6T	96 x 96	CS916130000
	7,8	etaSMART 8T	144 x 144	CS916140000
	9,10,11,12	etaSMART 12T	144 x 144	CS916150000
	13,14,15	etaSMART 15T	144 x 144	CS916160000

etaCON M

The etaCON M Series are micro-processor based power factor controllers which automatically correct power factor, with the help of contactors by switching the required number of capacitor banks.

The etaCON M controller offers power factor correction without any need for manual intervention. It decides the optimum configuration of capacitor banks to achieve desired power factor by taking into consideration the kVAR of each step, the number of operations, total usage time, re-connection time of each step, etc. The intelligent adjustment interface helps in achieving balanced capacitor usage ensuring longer life for switchgear and capacitors. Besides, manual switching of capacitors is also possible directly through the controller.

The maximum no. of steps in etaCON M Series can go up to 14.

The etaCON M Series is modular in design. The base controller comes with 3 steps, 5 steps (96 x 96 mm) and 8 steps (144 x 144 mm). The functionality of these base controllers can be enhanced with help of Plug-in Modules. "etaCON M - 3 step controller (96 x 96)" can accommodate 1 plug-in module and thus is expandable up to 6 steps. "etaCON M - 5 step controller (96 x 96)" can accommodate 1 plug-in module and thus is expandable up to 8 steps. "etaCON M - 8 step controller (144 x 144 mm)" can accommodate up to 2 plug-in modules and thus is expandable up to 14 steps. The following table provides description of Plug-in Modules:



Plug-in Module Type	Description
2 steps Plug-in Module	2 Relay outputs
3 steps Plug-in Module	3 Relay outputs
RS485 Plug-in Module	For communication on Modbus RS485

Salient Features



BACKLIT LCD DISPLAY

Backlit icon LCD with excellent information display. In presence of alarm, a scrolling text appears on screen. All parameters can be viewed on the screen, at a single go.



COMPACT RELAY

Compact Relay of 96x96 (WxH in mm) for 3 steps & 5 steps (extendable upto 8 steps) and 144 x 144 (WxH in mm) for 8 steps (extendable upto 14 steps) for space economy.



MEASUREMENT OF I-THD AND V-THD

etaCON M relay can measure I-THD and V-THD upto 15th order.

AUTOMATIC RECOGNITION OF CURRENT FLOW DIRECTION

etaCON M detects the CT reversal and automatically corrects the same. This saves the effort put into the detection/correction of CT polarity at site.



DISPLAY OF AVERAGE WEEKLY POWER FACTOR

Average value of power factor of last seven days is displayed and updated every day for assessment of APFC panel performance.

INTELLIGENT SWITCHING SENSITIVITY

Hunting of capacitors is avoided by faster switching of step in case of higher kVAR demand and more delay in case of smaller demand.



KEYPAD LOCK

The keypad lock function eliminates unauthorized modification of operating parameters.



PROVISION OF ALARMS

Alarms for Under/Over compensation, Low/High current, Low/High voltage, Capacitor overload due to harmonic voltage, over temperature, V-THD too high, I-THD too high, Maintenance request, Step failure.

CAPACITOR HEALTH MONITORING

etaCON M measures the percentage of the residual power of the steps which is compared with the original power programmed value. When the percentage results to be below the threshold set, the step failure alarm gets activated.



PROTECTION OF PANEL FROM OVER-HEATING

An inbuilt temperature sensor monitors temperature variation of the panel. Alarm is triggered in case of over-heating. Fan start & stop temperature can be set to operate cooling fans.

HT AND LT SENSING

Sensing at LT

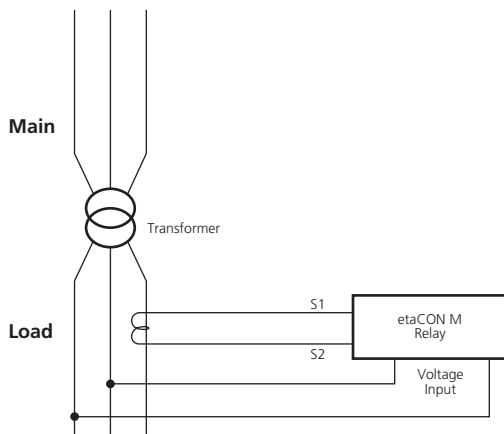

Sensing at HT

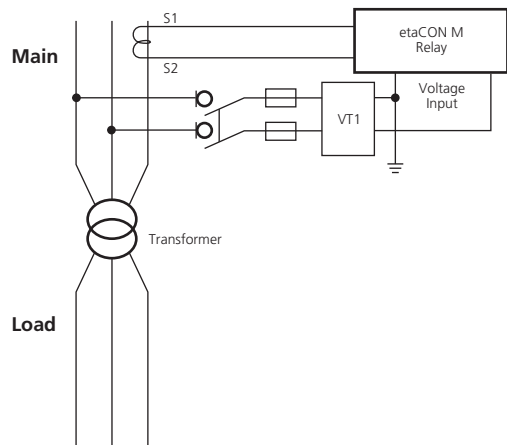

Technical Specifications

Parameter	etaCON M with 3 steps & 5 steps	etaCON M with 8 steps
No. of steps*	3, 5, 6, 7, 8	8, 10, 11, 12, 13, 14
Design	Digital microprocessor based	
Display	LCD Display	
Size (W x H in mm)	96 x 96	144 x 144
Measurements	PF, V, I, Required kVAR, capacitor overload, Panel Temperature, Average Weekly PF, No. of switching of each step, V-THD & I-THD up to 15 th order	
Metering/Logging	Maximum voltage and current value, Maximum capacitor overload value, Maximum panel temperature value	
Settings	Target PF adjustment: 0.5 Inductive to 0.5 Capacitive	
	Reconnection time of same capacitor - 1 to 30000s	
	Switching time sensitivity - 1 to 1000s	
Alarms	Under/Over Compensation, Low/High Current, Low/High Voltage, Capacitor Overload, Over temperature, Voltage THD too high, Current THD too high	
Supply		
Auxiliary Voltage	100 - 440V	
Frequency	45 - 66Hz	
Power consumption/dissipation	3.5W - 9.5VA	100V: 2W - 4VA 440V: 3W - 8.5VA
No-voltage release	≥ 8ms	
Immunity time for microbreakings	≤ 25ms	
Voltage inputs		
Maximum rated voltage (Ue)	600VAC L-L (346VAC L-N)	
Measuring range	50-720V L-L (415VAC L-N)	
Frequency range	45-65Hz	
Measuring method	True RMS	
Measuring input impedance	> 0.55MΩ L-N	> 15MΩ
	> 1.10MΩ L-L	
Accuracy of measurement	1% ±0.5 digit	
Current inputs		
Rated current (Ie)	1A or 5A	
Measuring range	For 5A scale: 0.025 - 6A	
	For 1A scale: 0.025 - 1.2A	
Type of input	Shunt supplied by an external current transformer (low voltage). Max 5A	
Measuring method	True RMS	
Overload capacity	+20% Ie	
Overload peak	50A for 1 second	
Accuracy of measurement	± 1% (0.1-1.2In) ±0.5 digit	
Power consumption	<0.6VA	
Relay output:	Output 1-2 of M3 / output 1-4 of M5	Output 1-7
Contact type	4 x 1 NO + contact common	7 x 1 NO + contact common
UL Rating	B300, 5A 250V 30V = 1A Pilot Duty	"B300, 5A 250V 30V= 1A Pilot Duty, 1.5A 440V Pilot Duty"
Max rated voltage	440V	
Rated current	AC1-5A 250V AC15-1.5A 440V	
Maximum current at contact common	10A	
Mechanical / electrical endurance	1x10 ⁷ / 1x10 ⁵ Operations	

Relay output:	Output 3 of M3 / Output 5 of M5	Output 8
Contact type	1 changeover	1 changeover
UL Rating	B300 / 30V=1A pilot duty	B300, 5A 250V
		30V=1A Pilot Duty, 1.5A 440V Pilot Duty
Max rated voltage	415V	440V
Rated current	AC1-5A 250V AC15-1.5A 440V	
Mechanical / electrical endurance	1x10 ⁷ / 1x10 ⁵ Operations	
Insulation		
Rated insulation voltage Ui	600V	
Rated impulse withstand voltage Uimp	9.5kV	
Power frequency withstand voltage	5.2kV	
Ambient conditions		
Operating temperature	-20°C to +60°C	
Storage temperature	-30°C to +80°C	
Relative humidity	<80% (IEC/EN 60068-2-78)	
Maximum pollution degree	2	
Overvoltage category	3	
Measurement category	III	
Climatic sequence	Z/ABDM (IEC/EN 60068-2-61)	
Shock resistance	15g (IEC/EN 60068-2-27)	
Vibration resistance	0.7g (IEC/EN 60068-2-6)	
Connections		
Terminal type	Plug-in / removable	
Conductor cross section (min-max)	0.2-2.5 mm ² (24-12 AWG)	
Tightening torque	0.56 Nm (5 lbin / 4-5 lbin per UL)	0.56 Nm (5 lbin)
Housing		
Version	Flush mount	
Material	Polycarbonate	
Degree of protection	IP54 on front with gasket, if mounted in class IP54 panel or better - IP20 terminals	IP65 on front with gasket if installed in a panel with the same IP protection - IP20 terminals
Weight	320g	640g
Certifications and compliance		
Comply with standards	IEC/EN 61010-1, IEC/EN 61010-2-30, IEC/EN 61000-6-2, IEC/EN 61000-6-4	

* Refer Selection Guideline at Page 90

Wiring Diagrams

etaCON M – 3 Steps & 5 Steps

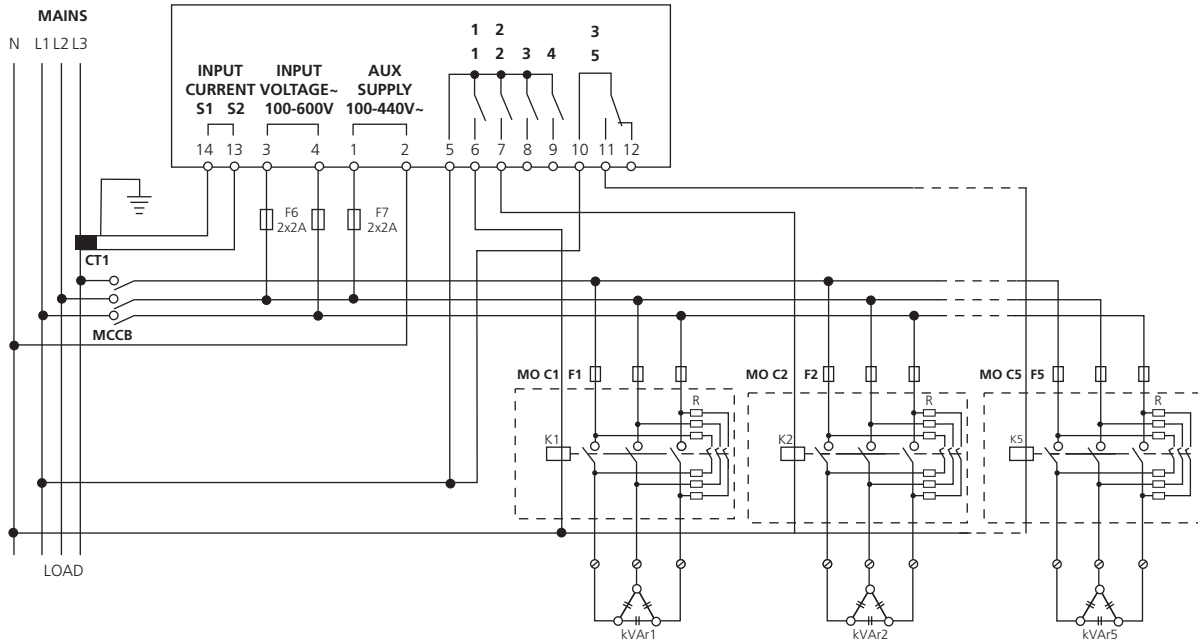

etaCON M - 8 steps

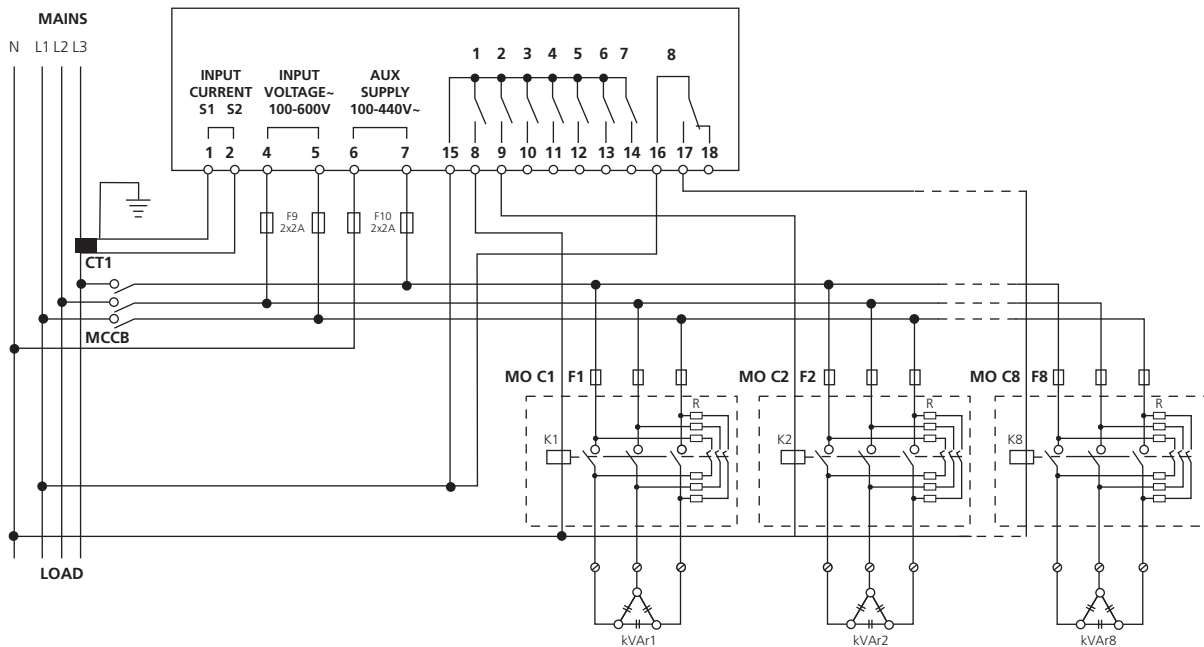

Note: 1. The polarity of current/voltage input is irrelevant.
 2. CT can be connected to any one of the three phases. The voltage input must be connected to the other two remaining phases.

Overall Dimensions

etaCON M - 3 Steps & 5 steps

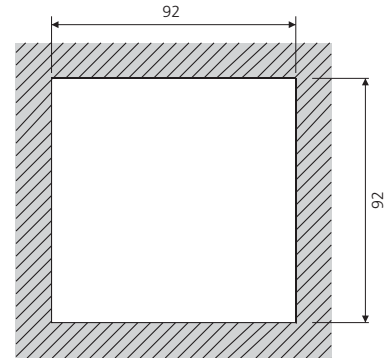
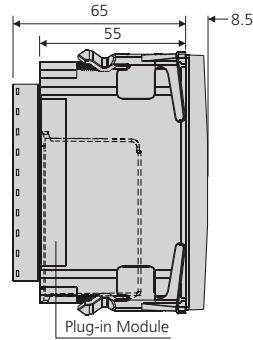
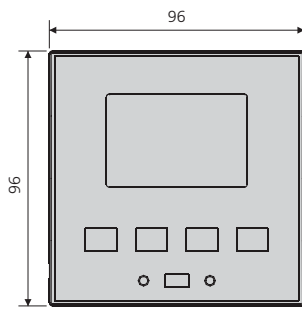

etaCON M - 8 steps

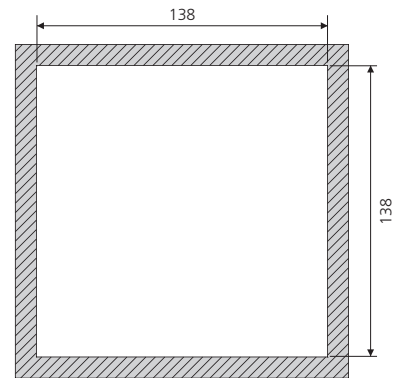
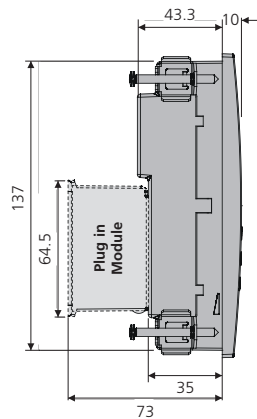
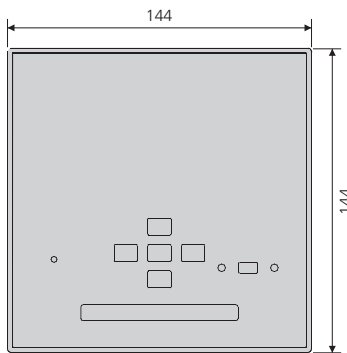

Dimensions in mm

etaCON M Series - APFC Relay Selection Guideline

Steps	Steps Description	Size (W x H in mm)	Combination	Cat. No. Combination
3	2+1*	96 x 96	3 Step APFC Relay	ETACONM003R
5	4+1*	96 x 96	5 Step APFC Relay	ETACONM005R
6	5+1*	96 x 96	3 Step APFC Relay + 3 Step Plug-in module	ETACONM003R + ETACONEXP3R
7	6+1*	96 x 96	5 Step APFC Relay + 2 Step Plug-in module	ETACONM005R + ETACONEXP2R
8	7+1*	96 x 96	5 Step APFC Relay + 3 Step Plug-in module	ETACONM005R + ETACONEXP3R
8	7+1*	144 x 144	8 Step APFC Relay	ETACONM008R
10	9+1*	144 x 144	8 Step Controller+2 Step Plug-in module	ETACONM008R + ETACONEXP2R
11	10+1*	144 x 144	8 Step Controller+3 Step Plug-in module	ETACONM008R + ETACONEXP3R
12	11+1*	144 x 144	8 Step APFC Relay + 2 Step Plug-in module + 2 Step Plug-in module	ETACONM008R + ETACONEXP2R + ETACONEXP2R
13	12+1*	144 x 144	8 Step APFC Relay + 2 Step Plug-in module + 3 Step Plug-in module	ETACONM008R + ETACONEXP2R + ETACONEXP3R
14	13+1*	144 x 144	8 Step APFC Relay + 3 Step Plug-in module + 3 Step Plug-in module	ETACONM008R + ETACONEXP3R + ETACONEXP3R

*Last Contact can be programmed for capacitor switching / Alarm function / Fan control

Ordering information:

etaCON M APFC Relay

Model	CT Secondary	Voltage Input	Cat. No.
3 Step APFC Relay (96 x 96)	1 A / 5 A	415V / 110V	ETACONM003R
5 Step APFC Relay (96 x 96)			ETACONM005R
8 Step APFC Relay (144 x 144)			ETACONM008R

etaCON M Optional Plug-in Modules

Description	Model	Cat. No.
2 Step Plug-in Module	2 Relays NO	ETACONEXP2R
3 Step Plug-in Module	3 Relays NO	ETACONEXP3R
RS485 Plug-in Module	RS485 Plug-in Module	ETACONRS485



Power Factor Correction Capacitors have been used for many years as the most cost effective solution for PF improvement. Modern electrical networks are continuously evolving into more complex installations due to the increasing usage of non-linear loads, sophisticated control & automation, UPS systems, energy efficiency improvement devices etc.

This evolution is also accompanied by increased dependency on captive power generation as well as growing concerns about incoming supply power quality.

In this background, it is necessary to evolve the Power Factor Correction solution also to a higher level so as to ensure sustainable achievement of high PF & acceptable harmonic distortion levels.

The selection of the correct type of PFC capacitors & filter reactors thus needs better understanding of the various issues involved.

This publication outlines a "5 Step" technology based approach, simplified for easier understanding to enable the correct selection of PFC Capacitors & Filter Reactors.

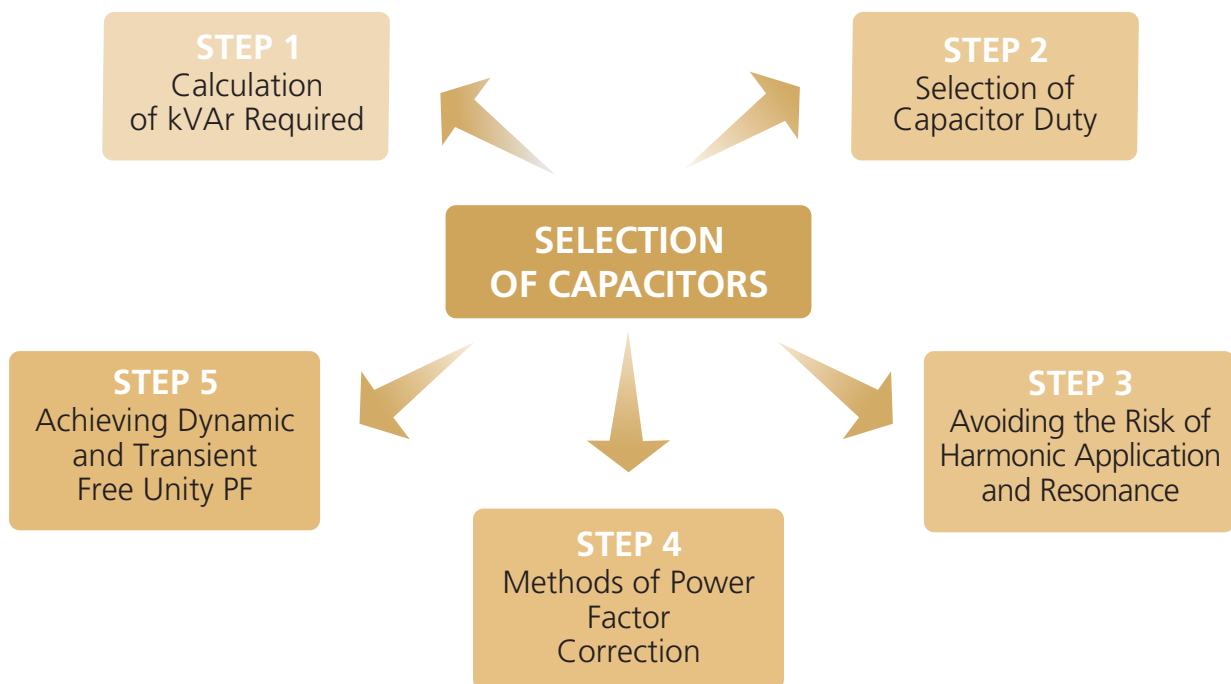

STEP 1: Calculation of kVAR Required for Industries & Distribution Networks

In electrical installations, the operating load kW and its average power factor (PF) can be ascertained from the electricity bill. Alternatively, it can also be easily evaluated by the formula:

$$\begin{aligned} \text{Average PF} &= \text{kW/kVA} \\ \text{Operating load kW} &= \text{kVA Demand} \times \text{Average PF} \end{aligned}$$

The average PF is considered as the initial PF and the final PF can be suitably assumed as target PF. In such cases, required capacitor kVAR can be calculated as explained in the example below:

Example: To calculate the required kVAR compensation for a 500 kW installation to improve the PF from 0.75 to 0.96

$$\text{kVAR} = \text{kW} \times \text{multiplying factor from table} = 500 \times 0.590 = 295 \text{ kVAR}$$

Note: Table is based on the following formula:

$$\text{kVAR required} = \text{kW} (\tan\theta_1 - \tan\theta_2)$$

$$\text{where } \theta_1 = \cos^{-1}(\text{PF}_1) \text{ and } \theta_2 = \cos^{-1}(\text{PF}_2).$$

Target PF Initial PF	0.9	0.91	0.92	0.93	0.94	0.95	0.96	0.97	0.98	0.99
0.4	1.807	1.836	1.865	1.896	1.928	1.963	2.000	2.041	2.088	2.149
0.42	1.676	1.705	1.735	1.766	1.798	1.832	1.869	1.910	1.958	2.018
0.44	1.557	1.585	1.615	1.646	1.678	1.712	1.749	1.790	1.838	1.898
0.46	1.446	1.475	1.504	1.535	1.567	1.602	1.639	1.680	1.727	1.788
0.48	1.343	1.372	1.402	1.432	1.465	1.499	1.536	1.577	1.625	1.685
0.5	1.248	1.276	1.306	1.337	1.369	1.403	1.440	1.481	1.529	1.590
0.52	1.158	1.187	1.217	1.247	1.280	1.314	1.351	1.392	1.440	1.500
0.54	1.074	1.103	1.133	1.163	1.196	1.230	1.267	1.308	1.356	1.416
0.56	0.995	1.024	1.053	1.084	1.116	1.151	1.188	1.229	1.276	1.337
0.58	0.920	0.949	0.979	1.009	1.042	1.076	1.113	1.154	1.201	1.262
0.6	0.849	0.878	0.907	0.938	0.970	1.005	1.042	1.083	1.130	1.191
0.62	0.781	0.810	0.839	0.870	0.903	0.937	0.974	1.015	1.062	1.123
0.64	0.716	0.745	0.775	0.805	0.838	0.872	0.909	0.950	0.998	1.058
0.66	0.654	0.683	0.712	0.743	0.775	0.810	0.847	0.888	0.935	0.996
0.68	0.594	0.623	0.652	0.683	0.715	0.750	0.787	0.828	0.875	0.936
0.7	0.536	0.565	0.594	0.625	0.657	0.692	0.729	0.770	0.817	0.878
0.72	0.480	0.508	0.538	0.569	0.601	0.635	0.672	0.713	0.761	0.821
0.74	0.425	0.453	0.483	0.514	0.546	0.580	0.617	0.658	0.706	0.766
0.75	0.38	0.426	0.456	0.487	0.519	0.553	0.590	0.631	0.679	0.739
0.76	0.371	0.400	0.429	0.460	0.492	0.526	0.563	0.605	0.652	0.713
0.78	0.318	0.347	0.376	0.407	0.439	0.474	0.511	0.552	0.600	0.660
0.8	0.266	0.294	0.324	0.355	0.387	0.421	0.458	0.499	0.547	0.608
0.82	0.214	0.242	0.272	0.303	0.335	0.369	0.406	0.447	0.495	0.556
0.84	0.162	0.190	0.220	0.251	0.283	0.317	0.354	0.395	0.443	0.503
0.85	0.135	0.164	0.194	0.225	0.257	0.291	0.328	0.369	0.417	0.477
0.86	0.109	0.138	0.167	0.198	0.230	0.265	0.302	0.343	0.390	0.451
0.87	0.082	0.111	0.141	0.172	0.204	0.238	0.275	0.316	0.364	0.424
0.88	0.055	0.084	0.114	0.145	0.177	0.211	0.248	0.289	0.337	0.397
0.89	0.028	0.057	0.086	0.117	0.149	0.184	0.221	0.262	0.309	0.370
0.9		0.029	0.058	0.089	0.121	0.156	0.193	0.234	0.281	0.342
0.91			0.030	0.060	0.093	0.127	0.164	0.205	0.253	0.313
0.92				0.031	0.063	0.097	0.134	0.175	0.223	0.284
0.93					0.032	0.067	0.104	0.145	0.192	0.253
0.94						0.034	0.071	0.112	0.160	0.220
0.95							0.037	0.078	0.126	0.186

Step 2: Selection of Capacitor Duty

The criteria for this classification is based on the following:

- Operating life
- Permissible over voltage & over current coupled with the time duration
- Number of Switching operations per Year
- Peak inrush current with standing capability
- Operating ambient temperature

Comparison of technical parameters

Duty	Over Current	Permissible Over Voltage @ Rated Voltage 440V	Peak Inrush Currents	Ambient Temperature	Maximum Switching Operations / Year	Life
Standard Duty	1.5 x In	1.1 Un (8h/24h)	200 x In	-25°C to 55°C	5000	1,00,000 hrs
Heavy Duty	1.8 x In	1.1 Un (8h/24h)	300 x In	-25°C to 55°C	8000	1,50,000 hrs
Gas Filled	1.8 x In	1.1 Un (8h/24h)	250 x In	-25°C to 55°C	8000	1,50,000 hrs
Super Heavy duty	2.5 x In	1.1 Un (8h/24h)	350 x In	-40°C to 65°C	15000	2,25,000 hrs at -40°C-60°C; 1,50,000 hrs at -40°C-65°C
APP	2.5 x In	1.1 Un (8h/24h)	300 x In	-5°C to 55°C	10000	2,00,000 hrs
LTXL: Ultra Heavy Duty	3 x In	1.1 Un (8h/24h)	500 x In	-25°C to 65°C	20000	3,00,000 hrs

Step 3: Avoiding the Risk of Harmonic Amplification and Resonance

This step is to make a choice between the use of Capacitors or Capacitors + Filter reactors.

In a system with inductive (X_L) and capacitive (X_C) impedances, resonance can happen at one particular frequency (resonant frequency, f_R).

$$\text{Resonant frequency, } f_R = \frac{1}{(2 \pi \sqrt{LC})}$$

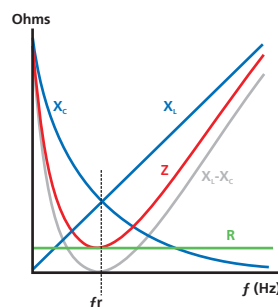

At this point X_L becomes equal to X_C and the net impedance becomes very low. Hence, at resonance point, the magnitude of the current (with frequency f_R) is very high and only inherent resistance in the network would limit the current. Typically, the resonance may create major problem in harmonics rich industry. The resonant frequency may match with any of the harmonic frequency and create very high harmonic amplification, which can create huge damage to the electrical equipment.

Addition of detuned reactors (in series to capacitors) forcefully shifts the resonant frequency to a safer level.

For example, combination of capacitor and 7% detuned filter reactor has the resonant frequency of 189 Hz, which will avoid resonance with 5th harmonic and above.

Solutions for Current & Voltage Harmonics

Current Harmonics (I_{THD})	Voltage Harmonics (V_{THD})	Recommended Solutions**
High	Low ($\leq 5\%$)	Detuned Harmonic Filter with 480 V (SHD/LTXL) Capacitors and/or Active Harmonic Filter
High	High ($>5\%$)	Detuned Harmonic Filter (High V-THD Withstand*) with 525V (SHD/LTXL Cyl) Capacitors and/or Active Harmonic Filter
Low	High ($>5\%$)	Grid may be polluted with imported voltage harmonics. It may not be possible to reduce them at the load side. Check with utility to rectify. However, Power factor correction can still be achieved with Detuned Harmonic Filter (High V-THD Withstand*) along with 525V capacitors.

**These are typical solutions. However the actual solution may vary depending up on the actual harmonic content in the system.

* For High V-THD applications, please contact E&A for customized solutions.

Step 4: Methods of Power Factor Correction

This aims at estimating whether fixed compensation or automatic compensation is to be used.

In order to achieve high power factor i.e., close to unity PF, the following guideline may be adopted to make a decision. If the total kVAr required by the installation is less than 15% of the rating of the incoming supply transformers, then the use of fixed capacitors may be adopted at various points in the installation.

If the kVAr required by the installation is more than 15% of the rating of the incoming supply transformers, then automatic power factor correction solution needs to be adopted.

APFC panels with suitable kVAr outputs may be distributed and connected across various points within the installation.

Note: De-tuned filter APFC panels must be selected if non-linear loads are present in the system.

Methods of Power Factor Compensation

	Individual Compensation	Group Compensation	Central Compensation
Control	Manual / Semi-automatic	Manual / Semi-automatic	Automatic
Elimination of penalties due to low PF	Yes	Yes	Yes
Achievement of Unity PF	No	No	Yes
Optimization of the kVA demand of the installation to the installed load in kW	Yes	Yes	Yes
Reduction of transformer loading	Yes	Yes	Yes
Reduction of transformer losses	Yes	Yes	Yes
Reduction of circuit breaker rating	Yes	Yes	Yes
Reduction of switchgear ratings and cable sizes down the line	Yes	Partial reduction	No
Reduction in I ² R losses	Yes	Partial reduction	No
Chance of leading PF	No	Yes	No
Advantages	Simple and inexpensive for few number of motors	Relatively better management of loads	Best suited for industries with large and variable loads
Disadvantages	Managing becomes difficult if the number of motors are more	Difficult to manage, if there is load variation in the group	Relatively expensive

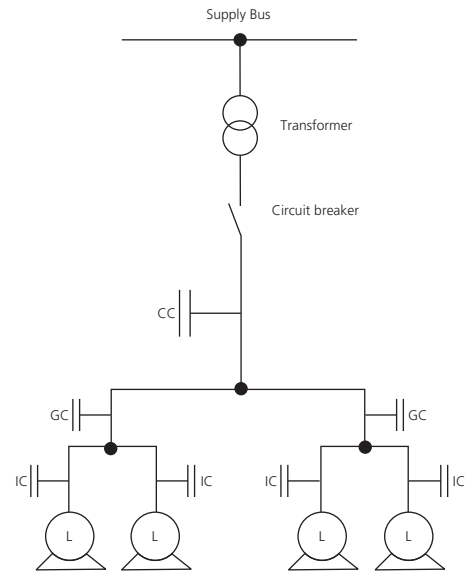

L : Inductive load
 IC : Individual Compensation
 GC : Group Compensation
 CC : Central Compensation

Step 5: To Achieve Dynamic and Transient Free Unity PF

Conventional switching techniques of capacitors involving electro-mechanical contactors may give rise to transient phenomena. This transient phenomena can interact with impedances present in the installation to create "Surges". This occurrence of surges can cause serious damage to sensitive electronics and automation resulting in either their malfunction or permanent damage. The transient phenomenon is a sudden rise in voltage or current at the point of switching.

In this background, it is important to ensure that all the capacitors installed are switched in a transient free manner so as to ensure reliable performance of the installation.

In such a situation, it is necessary to specify the use of Thyristor switches for transient free switching of Capacitors.

Note: Thyristor switching can also be used for dynamic compensation which is needed if the fluctuation of loads is very high; such as lifts, welding load is very high; fast presses etc.

The various methods of power factor correction are direct compensation, group compensation and centralized compensation. Depending upon the size and the rate of change of loads in an industry, any one or combination of the above methods can be employed. Specifically, in case of agricultural pump-sets and some small scale industries with a few motor loads, the power factor correction can be done by connecting shunt capacitors directly to the motors. This method of compensation is called direct compensation. This is simple and ideal method for reactive power compensation, as this results in rating optimization of all the upstream switchgear and cables, which reduces overall system losses.

Direct motor compensation can be done by two methods:

Method – 1:

As shown in the figure, the capacitor is connected directly to the motor terminals, after the starter. The capacitors would start supplying reactive power, as soon as the motor is switched ON. This method of compensation can be used for motors with Direct on-line starters. Usually the kVAr rating for a particular motor is given by the respective motor manufacturers, as the kVAr ratings are motor specific.

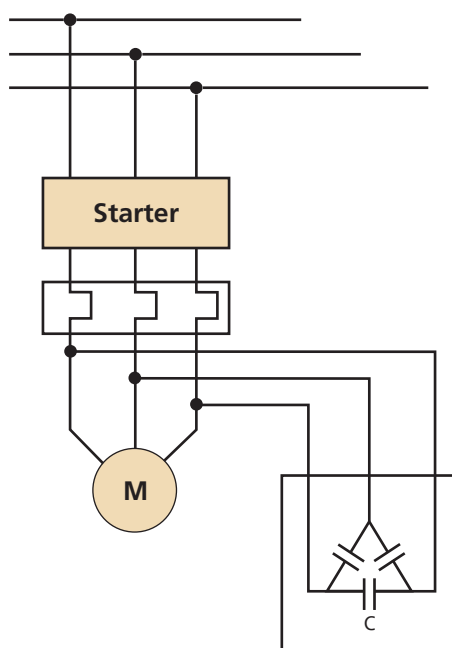

Motor (hp)	3000 rpm	1500 rpm	1000 rpm	750 rpm	500 rpm
2.5	1	1	1.5	2	2.5
5	2	2	2.5	3.5	4
7.5	2.5	3	3.5	4.5	5.5
10	3	4	4.5	5.5	6.5
15	4	5	6	7.5	9
20	5	6	7	9	12
25	6	7	9	10.5	14.5
30	7	8	10	12	17
40	9	10	13	15	21
50	11	12.5	16	18	25
60	13	14.5	18	20	28
70	15	16.5	20	22	31
80	17	19	22	24	34
90	19	21	24	26	37
100	21	23	26	28	40
110	23	25	28	30	43
120	25	27	30	32	46
130	27	29	32	34	49
140	29	31	34	36	52
145	30	32	35	37	54
150	31	33	36	38	55
155	32	34	37	39	56
160	33	35	38	40	57
165	34	36	39	41	59
170	35	37	40	42	60
175	36	38	41	43	61
180	37	39	42	44	62
185	38	40	43	45	63
190	38	40	43	45	65
200	40	42	45	47	67
250	45	50	55	60	70

Even though this is the effective method of power factor compensation, there is a limitation in sizing of the capacitors. That is, the maximum kVAr should be decided such that, the rated capacitor current is less than 90% of the motor's no-load current. If this condition is not met, self-excitation may occur, in which the motor acts as a generator. This happens when a motor has enough inertia to keep rotating even after being disconnected from the power system and the capacitor is large enough to supply the reactive power needs of the motor. Self-excitation may result in high voltage at the terminals of the motor and this can damage the contactor and the capacitor. As this method has the limitation in the sizing of maximum kVAr rating, it is not possible to achieve unity power factor.

Method – 2:

In this method, the capacitor is connected to the motor before the starter and it is switched through a separate capacitor-duty contactor. The capacitors are disconnected as soon as the motor is switched off hence, self-excitation is avoided. There is no need of any limitations in capacitor sizing and unity power factor can be achieved by this method.

The capacitor size (in kVAR) can be calculated by the below formula:

$$\text{kVAR} = \text{kW} (\tan \phi_1 - \tan \phi_2)$$

where, $\Phi_1 = \cos^{-1}$ (Initial PF) and $\Phi_2 = \cos^{-1}$ (Target PF)

The limitations are the manual switching of the capacitors and the extra cost incurred for the contactors. Moreover, when the number of motors increase in future, managing all at a time would be difficult.

Motors with Star-Delta Starter

Specifically for motor with star-delta starter, it is recommended to use method-2. If capacitors are directly connected to the terminals of the motor, the life of the capacitor drops drastically because of the voltage spikes that happen during every star to delta transition. So it is safer to connect the capacitor before the star-delta starter, as shown in the above figure.

Points to remember

- The operating power factor varies with respect to the percentage loading of the motors. Hence with the varying load, the fixed capacitors may not be able to maintain the unity power factor continuously.
- After switching off the capacitor, it is very important to maintain a minimum time delay of 60 seconds, for switching ON the capacitor again. Else, there are more chances of contactor damage because of charged capacitor.
- If the motor is operated with drives/converters, it is recommended to detune the capacitors by adding series reactors.
- It is recommended to use capacitor duty contactors for minimizing the inrush current and hence to maximize the life of contactors and the capacitors.

In order to achieve near unity power factor, all sources of reactive power need to be identified and fully compensated. One such element that consumes reactive power is the transformer. Reactive power is consumed by transformers through the no load magnetizing current and through the leakage reactance. This section is aimed at helping customers size capacitor banks for transformer compensation.

Basics

The power factor on the HT side (source side) of a transformer depends upon the following:

- LT Side (Load side) power factor
- Real power consumed by transformer
- Reactive power consumed by transformer

The load side power factor is compensated by employing APFC panels and/or by providing individual compensation to connected loads. Transformer compensation on the other hand needs a different approach.

The equivalent circuit of a transformer is as shown below:

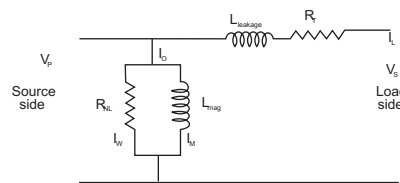

Where: V_p is the source voltage, V_s is the load voltage, I_o is the no load current, I_w is the no load watt loss current, I_m is the magnetizing current, R_{NL} is the no load resistance, L_{mag} is the magnetizing inductance, $L_{leakage}$ is the leakage inductance, R_T is the winding resistance.

As can be seen from the equivalent circuit, the inductive elements, namely L_{mag} and $L_{leakage}$ contribute to the VAR consumption of the transformer

Magnetizing VAR Requirement of A Transformer

The magnetizing VAR consumption is a function of the rated voltage and the magnetizing current of the transformer. The no load current of a transformer varies between 0.5 % and 2.5% of the full load current depending on the design of the transformer and the operating flux level. The magnetizing current is around 80% of the no load current and thus varies between 0.4% and 2%. It is safe to assume a value of 1-1.2% for distribution transformers.

Thus the VAR required to compensate for the magnetizing current of the transformer is around 1- 1.2% of the transformer kVA rating.

VAR Requirement Due to Leakage Reactance

The VAR requirement due to leakage reactance is a function of the square of the current and the leakage reactance. At full load the voltage drop across the leakage reactance is equal to the impedance voltage (%Z impedance). The reactive VAR consumption is equal to the product of impedance voltage and load current.

$$Q_x = I_L^2 \times X_{Leakage};$$

Where I_L is the load current and $X_{Leakage}$ is the leakage reactance; Q_x is the kVAR

Power Requirement

Typically, for a 3 phase transformer,

$$X_{leakage} = \frac{V_2^2}{kVA} \times (\%Z);$$

Where V_2 is the secondary voltage.

$$Q_x = (\%Z) \times (kVA) \times (\%load)^2$$

% loading is assumed to be 50% to 75%. Thus for % Z=5%, Q_x works out to $5\% \times (75\%)$ i.e. 3%

Thus the kVAR requirement to compensate for the leakage reactance of the transformer is around 3% of the kVA rating of the transformer.

The total kVAR required to compensate for the reactive power consumed by the transformer is around 4% to 4.25% of the kVA rating of the transformer.

Whenever an industry is drawing power from utility, there are no major complications in managing the reactive power and power factor close to unity can be maintained. However, when diesel generators are operating, some precautions are needed to be taken for managing reactive power. This section briefs the performance of the DG sets at various power factors and thereby shows the optimal manner of power factor compensation of generators with the help of some examples.

Normally DG sets are rated in apparent power (kVA) along with power factor and typical rated power factor is 0.8 lag (considering the power factor of motors, without any capacitors) irrespective of alternator's apparent power. The diesel engine's mechanical output power (bhp/kW) is designed to match the electrical real power ($kW = kVA \times PF$) of the alternator.

For example, consider a generator rated for 1000 kVA and lagging power factor of 0.8. The maximum possible real power (kW) the generator can supply is 800 kW (rated current = 1739 A). Thus, the diesel engine will also be rated to deliver 800 kW equivalent mechanical power to the alternator. The following cases show the operation of the alternator at different power factor.

Case 1:

Apparent power = 1000 kVA; connected load = 800 kW; power factor = 0.8

Current drawn, $I_1 = 1000 \times 1000 / (1.732 \times 415 \times 0.8) = 1739 \text{ A}$

- Here, the generator is operated at the rated name plate values. The load draws maximum rated current from the generator and the generator draws the maximum permissible mechanical power (800 kW) from the diesel engine.

Case 2:

Apparent power = 1000 kVA; connected load = 800 kW; power factor = 0.6

Current drawn, $I_2 = 1000 \times 1000 / (1.732 \times 415 \times 0.6) = 2318.9 \text{ A}$

- In case 2, the connected load is 800 kW (operated at 0.6 PF) which is equal to the maximum mechanical power that the engine can deliver. But the actual current drawn by the load is greater than the rated alternator current. This results in generator overloading. In order to avoid generator overloading, the maximum load (at the same PF) that can be connected to the generator is 600 kW at 0.6 PF.
- Conversely, if the connected load is 600 kW and if the power factor is at 0.6, the entire generator capacity (1000 kVA) is blocked for this partial load. If the power factor was to be improved to 0.8, then as in case 1 additional 200 kW load could have been connected to the same generator, thereby increasing the capacity and productivity of the industry. Moreover, if 600 kW load is operated at unity power factor, the load current (1391 A) will be reduced by 40%, thereby significant reduction in the copper loss/cable loss. This will result in fuel savings of the engine. This is what is described in case 3 below.

Case 3:

Apparent power = 1000 kVA; connected load = 800 kW; power factor = 1.0

Current drawn, $I_3 = 1000 \times 1000 / (1.732 \times 415 \times 1.0) = 1391 \text{ A}$

- The genset is connected to its full capacity of 800 kW operating at unity power factor. Unlike case 1, the load draws 20% less current at UPF (1391 A). This in turn results in significant reduction in copper loss/cable loss and thereby saving some fuel.
- Here, at UPF, even though the generator can support a load of 1000 kW, the diesel engine is rated to deliver a maximum mechanical power of 800 kW.
- Even though the current drawn is less than the rated current (1739 A), the genset is delivering its maximum real power (800 kW).
- Hence at UPF, utmost care should be taken such that the total connected electrical load must not exceed 800 kW. Otherwise the diesel engine will be overloaded.

Summary

- Close to unity power factor shall be maintained for the loads connected to the DG sets by using capacitors. This will result in the reduction of copper loss and hence savings in fuel.
- The load (active power) connected to the generator must not exceed the engine's equivalent kW rating.



Modern power networks cater to a wide variety of electrical and power electronics loads, which create a varying power demand on the supply system. In case of such varying loads, the power factor also varies as a function of the load requirements.

It therefore becomes practically difficult to maintain consistent power factor by the use of fixed compensation i.e. fixed capacitors which shall need to be manually switched to suit the variations of the load. This will lead to situations where the installation can have a low power factor leading to higher demand charges and levy of power factor penalties.

In addition to not being able to achieve the desired power factor it is also possible that the use of fixed compensation can also result in leading power factor under certain load conditions. This is also unhealthy for the installation as it can result in over voltages, saturation of transformers, mal-operation of diesel generating sets, penalties by electricity supply authorities etc.

Consequently the use of fixed compensation has limitations in this context. It is therefore necessary to automatically vary, without manual intervention, the compensation to suit the load requirements. This is achieved by using an Automatic Power Factor Correction (APFC) system which can ensure consistently high power factor without any manual intervention. In addition, the occurrence of leading power factor will be prevented.

APFC Panels are Fully Automatic in Operation and can be used to Achieve:

- Consistently high power factor under fluctuating load conditions
- Elimination of low power factor penalty levied by electrical supply authorities
- Reduced kVA demand charges
- Lower energy consumption in the installation by reducing losses
- Preventive leading power factor in an installation

Basic Operation

- To continuously sense and monitor the load condition by the use of external CT (whose output is fed to the control relay)
- To automatically switch ON and OFF relevant capacitor steps on to ensure consistent power factor
- To ensure easy user interface for enabling reliable system operations
- To protect against any electrical faults in a manner that will ensure safe isolation of the power factor correction equipment

Salient Features and Advantages

- Pre-selected optimal number of steps and step sizes, for better step resolution and hunt free capacitor switching
- Ideal switchgear selection for reliable short circuit protection, without nuisance tripping
- Right capacitor-reactor combination selection to prevent harmonic amplification and resonance
- Option of capacitor duty contactor or thyristor switch for transient free switching
- Panels with better electrical, mechanical and thermal design for longer life of capacitors and other components
- Panels are with advanced microcontroller based APFC relay that offers reliable switching operation with four quadrant sensing

etaSYS Standard APFC Panel Range

Product	Description	kVAR ratings	Capacitors	Main Incomer	Branch Protection	Switching	Harmonic Filter
etaSYS - MH1	Contactors switched standard APFC Panels	35 to 500 kVAR	Super Heavy duty	MCCB - upto 350 kVAR; ACB - 400 to 500 kVAR	MCCB	MO C Capacitor duty contactor	-
etaSYS - MH2	Contactors switched standard APFC Panels with harmonic filters	100 to 500 kVAR	Super Heavy duty	MCCB - upto 350 kVAR; ACB - 400 to 500 kVAR	MCCB	MO C Capacitor duty contactor	7% copper reactor
etaSYS - FH1	Contactors switched standard APFC Panels	35 to 500 kVAR	Super Heavy duty	MCCB - upto 350 kVAR; ACB - 400 to 500 kVAR	HRC Fuse	MO C Capacitor duty contactor	-
etaSYS - FH2	Contactors switched standard APFC Panels with harmonic filters	100 to 500 kVAR	Super Heavy duty	MCCB - upto 350 kVAR; ACB - 400 to 500 kVAR	HRC Fuse	MO C Capacitor duty contactor	7% copper reactor
etaSYS - FH3 (RTPFC)	Thyristor switched standard APFC Panels with harmonic filters	100 to 500 kVAR	Super Heavy duty	MCCB - upto 350 kVAR; ACB - 400 to 500 kVAR	Semiconductor Fuse	Thyristor switching modules	7% copper reactor
etaSYS - MU1	Contactors switched standard APFC Panels	100 to 500 kVAR	LTXL - Ultra Heavy Duty capacitor	MCCB - upto 350 kVAR; ACB - 400 to 500 kVAR	MCCB	MO C Capacitor duty contactor	-
etaSYS - MU2	Contactors switched standard APFC Panels with harmonic filters	100 to 500 kVAR	LTXL - Ultra Heavy Duty capacitor	MCCB - upto 350 kVAR; ACB - 400 to 500 kVAR	MCCB	MO C Capacitor duty contactor	7% copper reactor
etaSYS - FU1	Contactors switched standard APFC Panels	35 to 500 kVAR	LTXL - Ultra Heavy Duty capacitor	MCCB - upto 350 kVAR; ACB - 400 to 500 kVAR	HRC Fuse	MO C Capacitor duty contactor	-
etaSYS - FU2	Contactors switched standard APFC Panels with harmonic filters	100 to 500 kVAR	LTXL - Ultra Heavy Duty capacitor	MCCB - upto 350 kVAR; ACB - 400 to 500 kVAR	HRC Fuse	MO C Capacitor duty contactor	7% copper reactor
etaSYS - FU3 (RTPFC)	Thyristor switched standard APFC Panels with harmonic filters	100 to 500 kVAR	LTXL - Ultra Heavy Duty capacitor	MCCB - upto 350 kVAR; ACB - 400 to 500 kVAR	Semiconductor Fuse	Thyristor switching modules	7% copper reactor

etaSYS Basic Design Specifications

Power Range	35 kVAR to 500 kVAR (other ratings with customizations available on request)
Rated System Voltage	440 V / 415 V / 400 V / 380 V
Rated Frequency	50 Hz
Incomer Short Circuit Rating	> 36 kA
Altitude	1000 m
Duty	Continuous
Ambient Temperature	-5°C to 45°C
Power Supply	Three phase, four line
Relay Current Input Signal	1A / 5A, from CT on line
Enclosures	The load bearing structure and the front door are made of 2 mm sheet steel
	The partition is made of 1.6 mm sheet steel
	The internal components are accessible on opening the front door
	Ingress protection - IP42
Installation	Indoor, wall mounted (upto 100 kVAR), floor mounted (100 kVAR and above) in a well-ventilated, non-dusty environment, cable entry from bottom
Incomer	3 Pole MCCBs upto 630 A, 3 Pole ACBs above 630 A
Capacitors	1. Heavy duty cylindrical gas filled capacitors
	2. Super Heavy Duty Capacitors
	3. LTXL Ultra Heavy Duty Capacitors (see below table for step ratings)
Reactors	1. Without reactor
	2. With 7% & 14% Detuned Reactors
Switching	1. 3 Pole MO C Capacitor duty contactors of adequate ratings for respective steps
	2. Thyristor Switching Modules of suitable ratings
Branch Protection	1. MCCBs for providing short circuit protection and isolation
	2. HRC Fuses of adequate ratings
	3. High speed fuse / semiconductor fuse for thyristor switched APFC panels

APFC Panel - Overall Dimensions

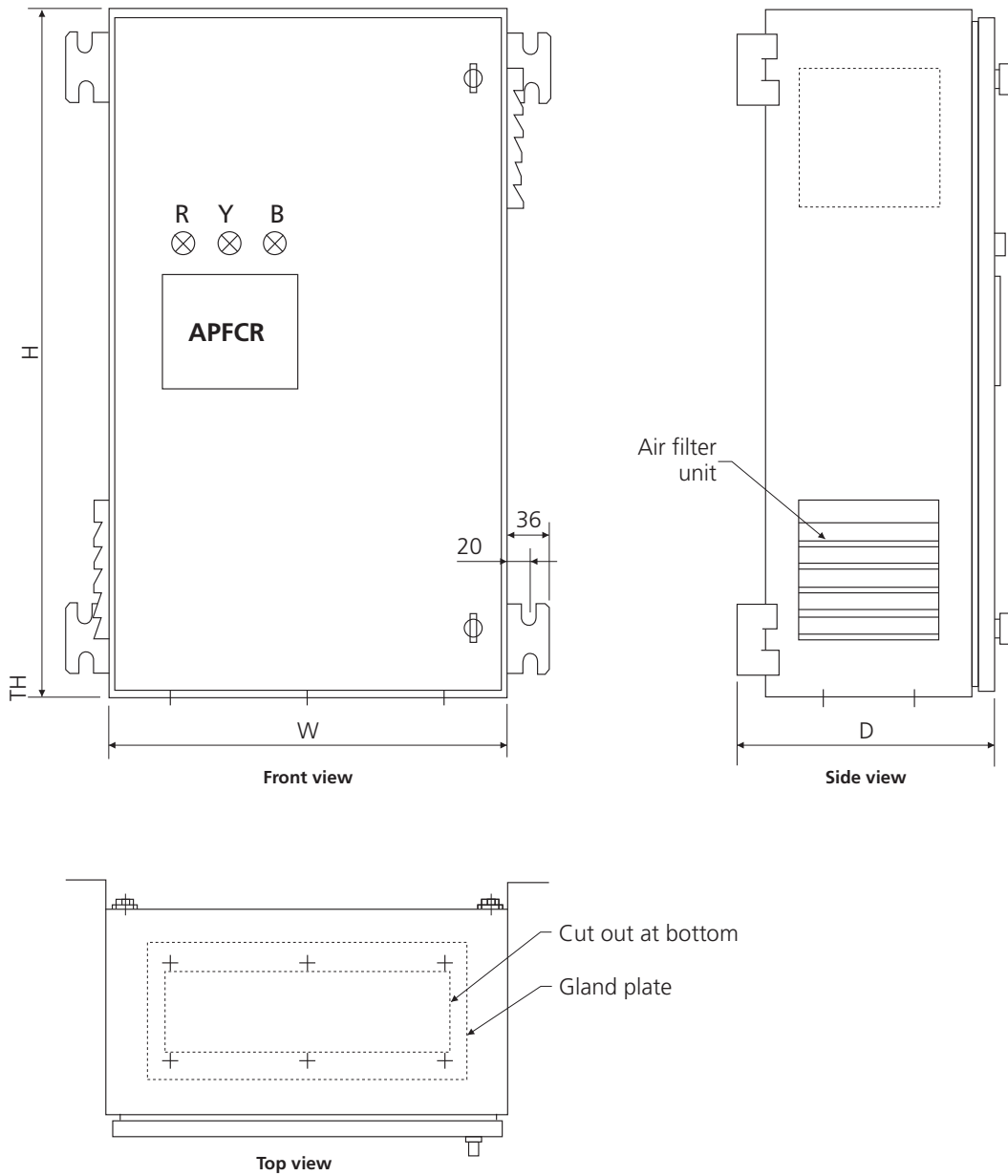

Notes:

- Wall mounted : upto 100 kVAR
- Floor mounted : above 100 kVAR
- Recommended front access : 1000 mm
- Recommended side clearance : 1000 mm
- Paint shade : RAL 7032 Powder coated
- Tolerance on dimensions : ± 10 mm
- Cable entry : bottom

etaSYS - MH1 Standard APFC with a combination of Super Heavy Duty Capacitors & MCCB

Cat. Nos.	Panel Rating (kVAr)	Step size (kVAr)	Steps	Switching Device	Type of Capacitor	Reactor	Branch Protection	Main Incomer	Dimension (mm) (H x W x D)*
LTAPMH0351B2	35	15 + 10 + 5 + 5	4	Contactora	MPP SHD	-	DU MCCB	dsine MCCB	1100 x 600 x 400
LTAPMH0501B2	50	25 + 10 x 2 + 5	5	Contactora	MPP SHD	-	DU MCCB	dsine MCCB	1100 x 600 x 400
LTAPMH0751B2	75	2 x 25 + 2 x 10 + 5	5	Contactora	MPP SHD	-	DU MCCB	dsine MCCB	1200 x 800 x 400
LTAPMH1001B2	100	50 + 25 + 15 + 5 x 2	5	Contactora	MPP SHD	-	DU MCCB	dsine MCCB	1500 x 1000 x 600
LTAPMH1251B2	125	50 + 25 x 2 + 10 x 2 + 5	5	Contactora	MPP SHD	-	DU MCCB	dsine MCCB	1500 x 1000 x 600
LTAPMH1501B2	150	50 + 25 x 3 + 15 + 10	6	Contactora	MPP SHD	-	DU MCCB	dsine MCCB	1800 x 1000 x 600
LTAPMH1751B2	175	50 x 2 + 25 x 2 + 15 + 10	6	Contactora	MPP SHD	-	DU MCCB	dsine MCCB	1800 x 1000 x 600
LTAPMH2001B2	200	50 x 3 + 25 x 1 + 15 + 10	6	Contactora	MPP SHD	-	DU MCCB	dsine MCCB	1800 x 1000 x 600
LTAPMH2251B2	225	50 x 3 + 25 x 1 + 15 + 10	6	Contactora	MPP SHD	-	DU MCCB	dsine MCCB	1800 x 1000 x 600
LTAPMH2501B2	250	2 x 25 + 4 x 50	6	Contactora	MPP SHD	-	DU MCCB	dsine MCCB	1800 x 1000 x 600
LTAPMH2751B2	275	1 x 100 + 3 x 50 + 2 x 12.5	6	Contactora	MPP SHD	-	DU MCCB	dsine MCCB	2100 x 1200 x 600
LTAPMH3001B2	300	1 x 100 + 3 x 50 + 2 x 25	6	Contactora	MPP SHD	-	DU MCCB	dsine MCCB	2100 x 1200 x 600
LTAPMH3501B2	350	1 x 100 + 3 x 50 + 4 x 25	8	Contactora	MPP SHD	-	DU MCCB	dsine MCCB	2100 x 1200 x 600
LTAPMH4001B2	400	2 x 100 + 2 x 50 + 4 x 25	8	Contactora	MPP SHD	-	DU MCCB	ACB	2000 x 1600 x 800
LTAPMH4501B2	450	2 x 100 + 4 x 50 + 2 x 25	8	Contactora	MPP SHD	-	DU MCCB	ACB	2000 x 1600 x 800
LTAPMH5001B2	500	3 x 100 + 3 x 50 + 2 x 25	8	Contactora	MPP SHD	-	DU MCCB	ACB	2000 x 1600 x 800

etaSYS - MH2 Standard APFC with a combination of Super Heavy Duty Capacitors, MCCB & 7% Detuned Reactor

Cat. Nos.	Panel Rating (kVAr)	Step size (kVAr)	Steps	Switching Device	Type of Capacitor	Reactor	Branch Protection	Main Incomer	Dimension (mm) (H x W x D)*
LTAPMH1002B2	100	50 + 25 + 15 + 5 x 2	5	Contactora	MPP SHD	7%	DU MCCB	dsine MCCB	1600 x 1000 x 800
LTAPMH1252B2	125	50 + 25 x 2 + 10 x 2 + 5	5	Contactora	MPP SHD	7%	DU MCCB	dsine MCCB	1600 x 1000 x 800
LTAPMH1502B2	150	50 + 25 x 3 + 15 + 10	6	Contactora	MPP SHD	7%	DU MCCB	dsine MCCB	2100 x 1000 x 800
LTAPMH1752B2	175	50 x 2 + 25 x 2 + 15 + 10	6	Contactora	MPP SHD	7%	DU MCCB	dsine MCCB	2100 x 1000 x 800
LTAPMH2002B2	200	50 x 3 + 25 x 1 + 15 + 10	6	Contactora	MPP SHD	7%	DU MCCB	dsine MCCB	2100 x 1000 x 800
LTAPMH2252B2	225	50 x 3 + 25 x 1 + 15 + 10	6	Contactora	MPP SHD	7%	DU MCCB	dsine MCCB	2100 x 1000 x 800
LTAPMH2502B2	250	2 x 25 + 4 x 50	6	Contactora	MPP SHD	7%	DU MCCB	dsine MCCB	2100 x 1000 x 800
LTAPMH2752B2	275	1 x 100 + 3 x 50 + 2 x 12.5	6	Contactora	MPP SHD	7%	DU MCCB	dsine MCCB	2100 x 1200 x 800
LTAPMH3002B2	300	1 x 100 + 3 x 50 + 2 x 25	6	Contactora	MPP SHD	7%	DU MCCB	dsine MCCB	2100 x 1200 x 800
LTAPMH3502B2	350	1 x 100 + 3 x 50 + 4 x 25	8	Contactora	MPP SHD	7%	DU MCCB	dsine MCCB	2100 x 1400 x 800
LTAPMH4002B2	400	2 x 100 + 2 x 50 + 4 x 25	8	Contactora	MPP SHD	7%	DU MCCB	ACB	2000 x 1600 x 1200
LTAPMH4502B2	450	2 x 100 + 4 x 50 + 2 x 25	8	Contactora	MPP SHD	7%	DU MCCB	ACB	2000 x 1600 x 1200
LTAPMH5002B2	500	3 x 100 + 3 x 50 + 2 x 25	8	Contactora	MPP SHD	7%	DU MCCB	ACB	2000 x 1600 x 1200

*Actual dimensions will be given in drawings

etaSYS - FH1 Standard APFC with a combination of Super Heavy Duty Capacitors & HRC Fuse

Cat. Nos.	Panel Rating (kVAr)	Step size (kVAr)	Steps	Switching Device	Type of Capacitor	Reactor	Branch Protection	Main Incomer	Dimension (mm) (H x W x D)*
LTAPFH0351B2	35	15 + 10 + 5 + 5	4	Contactora	MPP SHD	-	HRCF	dsine MCCB	1100 x 600 x 400
LTAPFH0501B2	50	25 + 10 x 2 + 5	5	Contactora	MPP SHD	-	HRCF	dsine MCCB	1100 x 600 x 400
LTAPFH0751B2	75	2 x 25 + 2 x 10 + 5	5	Contactora	MPP SHD	-	HRCF	dsine MCCB	1200 x 800x 400
LTAPFH1001B2	100	50 + 25 + 15 + 5 x 2	5	Contactora	MPP SHD	-	HRCF	dsine MCCB	1500 x 1000 x 500
LTAPFH1251B2	125	50 + 25 x 2 + 10 x 2 + 5	5	Contactora	MPP SHD	-	HRCF	dsine MCCB	1500 x 1000 x 500
LTAPFH1501B2	150	50 + 25 x 3 + 15 + 10	6	Contactora	MPP SHD	-	HRCF	dsine MCCB	1800 x 1000 x 600
LTAPFH1751B2	175	50 x 2 + 25 x 2 + 15 + 10	6	Contactora	MPP SHD	-	HRCF	dsine MCCB	1800 x 1000 x 600
LTAPFH2001B2	200	50 x 3 + 25 x 1 + 15 + 10	6	Contactora	MPP SHD	-	HRCF	dsine MCCB	1800 x 1000 x 600
LTAPFH2251B2	225	50 x 3 + 25 x 1 + 15 + 10	6	Contactora	MPP SHD	-	HRCF	dsine MCCB	1800 x 1000 x 600
LTAPFH2501B2	250	2 x 25 + 4 x 50	6	Contactora	MPP SHD	-	HRCF	dsine MCCB	1800 x 1000 x 600
LTAPFH2751B2	275	1 x 100 + 3 x 50 + 2 x 12.5	6	Contactora	MPP SHD	-	HRCF	dsine MCCB	2100 x 1200 x 600
LTAPFH3001B2	300	1 x 100 + 3 x 50 + 2 x 25	6	Contactora	MPP SHD	-	HRCF	dsine MCCB	2100 x 1200 x 600
LTAPFH3501B2	350	1 x 100 + 3 x 50 + 4 x 25	8	Contactora	MPP SHD	-	HRCF	dsine MCCB	2100 x 1200 x 600
LTAPFH4001B2	400	2 x 100 + 2 x 50 + 4 x 25	8	Contactora	MPP SHD	-	HRCF	ACB	2000 x 1600 x 800
LTAPFH4501B2	450	2 x 100 + 4 x 50 + 2 x 25	8	Contactora	MPP SHD	-	HRCF	ACB	2000 x 1600 x 800
LTAPFH5001B2	500	3 x 100 + 3 x 50 + 2 x 25	8	Contactora	MPP SHD	-	HRCF	ACB	2000 x 1600 x 800

etaSYS - FH2 Standard APFC with a combination of Super Heavy Duty Capacitors, HRC Fuse & 7% Detuned Reactor

Cat. Nos.	Panel Rating (kVAr)	Step size (kVAr)	Steps	Switching Device	Type of Capacitor	Reactor	Branch Protection	Main Incomer	Dimension (mm) (H x W x D)*
LTAPFH1002B2	100	50 + 25 + 15 + 5 x 2	5	Contactora	MPP SHD	7%	HRCF	dsine MCCB	1600 x 1000 x 800
LTAPFH1252B2	125	50 + 25 x 2 + 10 x 2 + 5	5	Contactora	MPP SHD	7%	HRCF	dsine MCCB	1600 x 1000 x 800
LTAPFH1502B2	150	50 + 25 x 3 + 15 + 10	6	Contactora	MPP SHD	7%	HRCF	dsine MCCB	2100 x 1000 x 800
LTAPFH1752B2	175	50 x 2 + 25 x 2 + 15 + 10	6	Contactora	MPP SHD	7%	HRCF	dsine MCCB	2100 x 1000 x 800
LTAPFH2002B2	200	50 x 3 + 25 x 1 + 15 + 10	6	Contactora	MPP SHD	7%	HRCF	dsine MCCB	2100 x 1000 x 800
LTAPFH2252B2	225	50 x 3 + 25 x 1 + 15 + 10	6	Contactora	MPP SHD	7%	HRCF	dsine MCCB	2100 x 1000 x 800
LTAPFH2502B2	250	2 x 25 + 4 x 50	6	Contactora	MPP SHD	7%	HRCF	dsine MCCB	2100 x 1000 x 800
LTAPFH2752B2	275	1 x 100 + 3 x 50 + 2 x 12.5	6	Contactora	MPP SHD	7%	HRCF	dsine MCCB	2100 x 1200 x 800
LTAPFH3002B2	300	1 x 100 + 3 x 50 + 2 x 25	6	Contactora	MPP SHD	7%	HRCF	dsine MCCB	2100 x 1200 x 800
LTAPFH3502B2	350	1 x 100 + 3 x 50 + 4 x 25	8	Contactora	MPP SHD	7%	HRCF	dsine MCCB	2100 x 1400 x 800
LTAPFH4002B2	400	2 x 100 + 2 x 50 + 4 x 25	8	Contactora	MPP SHD	7%	HRCF	ACB	2000 x 1600 x 1200
LTAPFH4502B2	450	2 x 100 + 4 x 50 + 2 x 25	8	Contactora	MPP SHD	7%	HRCF	ACB	2000 x 1600 x 1200
LTAPFH5002B2	500	3 x 100 + 3 x 50 + 2 x 25	8	Contactora	MPP SHD	7%	HRCF	ACB	2000 x 1600 x 1200

etaSYS - FH3 Standard APFC with a combination of Super Heavy Duty Capacitors, Thyristor Switching & 7% Detuned Reactor

Cat. Nos.	Panel Rating (kVAr)	Step size (kVAr)	Steps	Switching Device	Type of Capacitor	Reactor	Branch Protection	Main Incomer	Dimension (mm) (H x W x D)*
LTAPFH1003B2	100	50 + 25 + 15 + 5 x 2	5	Thyristor	MPP SHD	7%	HSF	dsine MCCB	1800 x 1000 x 800
LTAPFH1253B2	125	50 + 25 x 2 + 10 x 2 + 5	5	Thyristor	MPP SHD	7%	HSF	dsine MCCB	1800 x 1000 x 800
LTAPFH1503B2	150	50 + 25 x 3 + 15 + 10	6	Thyristor	MPP SHD	7%	HSF	dsine MCCB	2100 x 1000 x 800
LTAPFH1753B2	175	50 x 2 + 25 x 2 + 15 + 10	6	Thyristor	MPP SHD	7%	HSF	dsine MCCB	2100 x 1000 x 800
LTAPFH2003B2	200	50 x 3 + 25 x 1 + 15 + 10	6	Thyristor	MPP SHD	7%	HSF	dsine MCCB	2100 x 1000 x 800
LTAPFH2253B2	225	50 x 3 + 25 x 1 + 15 + 10	6	Thyristor	MPP SHD	7%	HSF	dsine MCCB	2100 x 1000 x 800
LTAPFH2503B2	250	2 x 25 + 4 x 50	6	Thyristor	MPP SHD	7%	HSF	dsine MCCB	2100 x 1000 x 800
LTAPFH2753B2	275	1 x 100 + 3 x 50 + 2 x 12.5	6	Thyristor	MPP SHD	7%	HSF	dsine MCCB	2200 x 1200 x 800
LTAPFH3003B2	300	1 x 100 + 3 x 50 + 2 x 25	6	Thyristor	MPP SHD	7%	HSF	dsine MCCB	2200 x 1200 x 800
LTAPFH3503B2	350	1 x 100 + 3 x 50 + 4 x 25	8	Thyristor	MPP SHD	7%	HSF	dsine MCCB	2100 x 1600 x 800
LTAPFH4003B2	400	2 x 100 + 2 x 50 + 4 x 25	8	Thyristor	MPP SHD	7%	HSF	ACB	2000 x 1600 x 1200
LTAPFH4503B2	450	2 x 100 + 4 x 50 + 2 x 25	8	Thyristor	MPP SHD	7%	HSF	ACB	2000 x 1600 x 1200
LTAPFH5003B2	500	3 x 100 + 3 x 50 + 2 x 25	8	Thyristor	MPP SHD	7%	HSF	ACB	2000 x 1600 x 1200

*Actual dimensions will be given in drawings

etaSYS - MU1 Standard APFC with a combination of LTXL Capacitors & MCCB

Cat. Nos.	Panel Rating (kVAr)	Step size (kVAr)	Steps	Switching Device	Type of Capacitor	Reactor	Branch Protection	Main Incomer	Dimension (mm) (H x W x D)*
LTAPMU1001B2	100	50 + 25 + 15 + 5 × 2	5	Contactator	LTXL	-	DU MCCB	dsine MCCB	1500 x 1000 x 700
LTAPMU1251B2	125	50 + 25 × 2 + 10 × 2 + 5	5	Contactator	LTXL	-	DU MCCB	dsine MCCB	1500 x 1000 x 700
LTAPMU1501B2	150	50 + 25 × 3 + 15 + 10	6	Contactator	LTXL	-	DU MCCB	dsine MCCB	1800 x 1000 x 700
LTAPMU1751B2	175	50 × 2 + 25 × 2 + 15 + 10	6	Contactator	LTXL	-	DU MCCB	dsine MCCB	1800 x 1000 x 700
LTAPMU2001B2	200	50 × 3 + 25 × 1 + 15 + 10	6	Contactator	LTXL	-	DU MCCB	dsine MCCB	1800 x 1000 x 700
LTAPMU2251B2	225	50 × 3 + 25 × 1 + 15 + 10	6	Contactator	LTXL	-	DU MCCB	dsine MCCB	1800 x 1000 x 700
LTAPMU2501B2	250	2 × 25 + 4 × 50	6	Contactator	LTXL	-	DU MCCB	dsine MCCB	1800 x 1000 x 700
LTAPMU2751B2	275	1 × 100 + 3 × 50 + 2 × 12.5	6	Contactator	LTXL	-	DU MCCB	dsine MCCB	2100 x 1200 x 700
LTAPMU3001B2	300	1 × 100 + 3 × 50 + 2 × 25	6	Contactator	LTXL	-	DU MCCB	dsine MCCB	2100 x 1200 x 700
LTAPMU3501B2	350	1 × 100 + 3 × 50 + 4 × 25	8	Contactator	LTXL	-	DU MCCB	dsine MCCB	2100 x 1200 x 700
LTAPMU4001B2	400	2 × 100 + 2 × 50 + 4 × 25	8	Contactator	LTXL	-	DU MCCB	ACB	2000 x 1600 x 1200
LTAPMU4501B2	450	2 × 100 + 4 × 50 + 2 × 25	8	Contactator	LTXL	-	DU MCCB	ACB	2000 x 1600 x 1200
LTAPMU5001B2	500	3 × 100 + 3 × 50 + 2 × 25	8	Contactator	LTXL	-	DU MCCB	ACB	2000 x 1600 x 1200

etaSYS - MU2 Standard APFC with a combination of LTXL Capacitors, MCCB & 7% Detuned Reactor

Cat. Nos.	Panel Rating (kVAr)	Step size (kVAr)	Steps	Switching Device	Type of Capacitor	Reactor	Branch Protection	Main Incomer	Dimension (mm) (H x W x D)*
LTAPMU1002B2	100	50 + 25 + 15 + 5 × 2	5	Contactator	LTXL	7%	DU MCCB	dsine MCCB	2100 x 1000 x 800
LTAPMU1252B2	125	50 + 25 × 2 + 10 × 2 + 5	5	Contactator	LTXL	7%	DU MCCB	dsine MCCB	2100 x 1000 x 800
LTAPMU1502B2	150	50 + 25 × 3 + 15 + 10	6	Contactator	LTXL	7%	DU MCCB	dsine MCCB	2100 x 1000 x 800
LTAPMU1752B2	175	50 × 2 + 25 × 2 + 15 + 10	6	Contactator	LTXL	7%	DU MCCB	dsine MCCB	2100 x 1000 x 800
LTAPMU2002B2	200	50 × 3 + 25 × 1 + 15 + 10	6	Contactator	LTXL	7%	DU MCCB	dsine MCCB	2100 x 1000 x 800
LTAPMU2252B2	225	50 × 3 + 25 × 1 + 15 + 10	6	Contactator	LTXL	7%	DU MCCB	dsine MCCB	2100 x 1000 x 800
LTAPMU2502B2	250	2 × 25 + 4 × 50	6	Contactator	LTXL	7%	DU MCCB	dsine MCCB	2100 x 1000 x 800
LTAPMU2752B2	275	1 × 100 + 3 × 50 + 2 × 12.5	6	Contactator	LTXL	7%	DU MCCB	dsine MCCB	2100 x 1200 x 1200
LTAPMU3002B2	300	1 × 100 + 3 × 50 + 2 × 25	6	Contactator	LTXL	7%	DU MCCB	dsine MCCB	2100 x 1200 x 1200
LTAPMU3502B2	350	1 × 100 + 3 × 50 + 4 × 25	8	Contactator	LTXL	7%	DU MCCB	dsine MCCB	2100 x 1400 x 1200
LTAPMU4002B2	400	2 × 100 + 2 × 50 + 4 × 25	8	Contactator	LTXL	7%	DU MCCB	ACB	2000 x 1800 x 1200
LTAPMU4502B2	450	2 × 100 + 4 × 50 + 2 × 25	8	Contactator	LTXL	7%	DU MCCB	ACB	2000 x 1800 x 1200
LTAPMU5002B2	500	3 × 100 + 3 × 50 + 2 × 25	8	Contactator	LTXL	7%	DU MCCB	ACB	2000 x 1800 x 1200

*Actual dimensions will be given in drawings

etaSYS - FU1 Standard APFC with a combination of LTXL Capacitors & HRC Fuse

Cat. Nos.	Panel Rating (kVAr)	Step size (kVAr)	Steps	Switching Device	Type of Capacitor	Reactor	Branch Protection	Main Incomer	Dimension (mm) (H x W x D)*
LTAPFU1001B2	100	50 + 25 + 15 + 5 x 2	5	Contactora	LTXL	-	HRCF	dsine MCCB	1500 x 1000 x 700
LTAPFU1251B2	125	50 + 25 x 2 + 10 x 2 + 5	5	Contactora	LTXL	-	HRCF	dsine MCCB	1500 x 1000 x 700
LTAPFU1501B2	150	50 + 25 x 3 + 15 + 10	6	Contactora	LTXL	-	HRCF	dsine MCCB	1800 x 1000 x 700
LTAPFU1751B2	175	50 x 2 + 25 x 2 + 15 + 10	6	Contactora	LTXL	-	HRCF	dsine MCCB	1800 x 1000 x 700
LTAPFU2001B2	200	50 x 3 + 25 x 1 + 15 + 10	6	Contactora	LTXL	-	HRCF	dsine MCCB	1800 x 1000 x 700
LTAPFU2251B2	225	50 x 3 + 25 x 1 + 15 + 10	6	Contactora	LTXL	-	HRCF	dsine MCCB	1800 x 1000 x 700
LTAPFU2501B2	250	2 x 25 + 4 x 50	6	Contactora	LTXL	-	HRCF	dsine MCCB	1800 x 1000 x 700
LTAPFU2751B2	275	1 x 100 + 3 x 50 + 2 x 12.5	6	Contactora	LTXL	-	HRCF	dsine MCCB	2100 x 1200 x 700
LTAPFU3001B2	300	1 x 100 + 3 x 50 + 2 x 25	6	Contactora	LTXL	-	HRCF	dsine MCCB	2100 x 1200 x 700
LTAPFU3501B2	350	1 x 100 + 3 x 50 + 4 x 25	8	Contactora	LTXL	-	HRCF	dsine MCCB	2000 x 1600 x 1200
LTAPFU4001B2	400	2 x 100 + 2 x 50 + 4 x 25	8	Contactora	LTXL	-	HRCF	ACB	2000 x 1600 x 1200
LTAPFU4501B2	450	2 x 100 + 4 x 50 + 2 x 25	8	Contactora	LTXL	-	HRCF	ACB	2000 x 1600 x 1200
LTAPFU5001B2	500	3 x 100 + 3 x 50 + 2 x 25	8	Contactora	LTXL	-	HRCF	ACB	2000 x 1600 x 1200

etaSYS - FU2 Standard APFC with a combination of LTXL Capacitors, HRC Fuse & 7% Detuned Reactor

Cat. Nos.	Panel Rating (kVAr)	Step size (kVAr)	Steps	Switching Device	Type of Capacitor	Reactor	Branch Protection	Main Incomer	Dimension (mm) (H x W x D)*
LTAPFU1002B2	100	50 + 25 + 15 + 5 x 2	5	Contactora	LTXL	7%	HRCF	dsine MCCB	2100 x 1000 x 800
LTAPFU1252B2	125	50 + 25 x 2 + 10 x 2 + 5	5	Contactora	LTXL	7%	HRCF	dsine MCCB	2100 x 1000 x 800
LTAPFU1502B2	150	50 + 25 x 3 + 15 + 10	6	Contactora	LTXL	7%	HRCF	dsine MCCB	2100 x 1000 x 800
LTAPFU1752B2	175	50 x 2 + 25 x 2 + 15 + 10	6	Contactora	LTXL	7%	HRCF	dsine MCCB	2100 x 1000 x 800
LTAPFU2002B2	200	50 x 3 + 25 x 1 + 15 + 10	6	Contactora	LTXL	7%	HRCF	dsine MCCB	2100 x 1000 x 800
LTAPFU2252B2	225	50 x 3 + 25 x 1 + 15 + 10	6	Contactora	LTXL	7%	HRCF	dsine MCCB	2100 x 1000 x 800
LTAPFU2502B2	250	2 x 25 + 4 x 50	6	Contactora	LTXL	7%	HRCF	dsine MCCB	2100 x 1000 x 800
LTAPFU2752B2	275	1 x 100 + 3 x 50 + 2 x 12.5	6	Contactora	LTXL	7%	HRCF	dsine MCCB	2100 x 1200 x 1200
LTAPFU3002B2	300	1 x 100 + 3 x 50 + 2 x 25	6	Contactora	LTXL	7%	HRCF	dsine MCCB	2100 x 1200 x 1200
LTAPFU3502B2	350	1 x 100 + 3 x 50 + 4 x 25	8	Contactora	LTXL	7%	HRCF	dsine MCCB	2100 x 1400 x 1200
LTAPFU4002B2	400	2 x 100 + 2 x 50 + 4 x 25	8	Contactora	LTXL	7%	HRCF	ACB	2000 x 1600 x 1200
LTAPFU4502B2	450	2 x 100 + 4 x 50 + 2 x 25	8	Contactora	LTXL	7%	HRCF	ACB	2000 x 1600 x 1200
LTAPFU5002B2	500	3 x 100 + 3 x 50 + 2 x 25	8	Contactora	LTXL	7%	HRCF	ACB	2000 x 1600 x 1200

etaSYS - FU3 Standard APFC with a combination of LTXL Capacitors, Thyristor Switching & 7% Detuned Reactor

Cat. Nos.	Panel Rating (kVAr)	Step size (kVAr)	Steps	Switching Device	Type of Capacitor	Reactor	Branch Protection	Main Incomer	Dimension (mm) (H x W x D)*
LTAPFU1003B2	100	50 + 25 + 15 + 5 x 2	5	Thyristor	LTXL	7%	HSF	dsine MCCB	2100 x 1000 x 800
LTAPFU1253B2	125	50 + 25 x 2 + 10 x 2 + 5	5	Thyristor	LTXL	7%	HSF	dsine MCCB	2100 x 1000 x 800
LTAPFU1503B2	150	50 + 25 x 3 + 15 + 10	6	Thyristor	LTXL	7%	HSF	dsine MCCB	2100 x 1000 x 800
LTAPFU1753B2	175	50 x 2 + 25 x 2 + 15 + 10	6	Thyristor	LTXL	7%	HSF	dsine MCCB	2100 x 1000 x 800
LTAPFU2003B2	200	50 x 3 + 25 x 1 + 15 + 10	6	Thyristor	LTXL	7%	HSF	dsine MCCB	2100 x 1000 x 800
LTAPFU2253B2	225	50 x 3 + 25 x 1 + 15 + 10	6	Thyristor	LTXL	7%	HSF	dsine MCCB	2100 x 1000 x 800
LTAPFU2503B2	250	2 x 25 + 4 x 50	6	Thyristor	LTXL	7%	HSF	dsine MCCB	2100 x 1000 x 800
LTAPFU2753B2	275	1 x 100 + 3 x 50 + 2 x 12.5	6	Thyristor	LTXL	7%	HSF	dsine MCCB	2200 x 1200 x 1200
LTAPFU3003B2	300	1 x 100 + 3 x 50 + 2 x 25	6	Thyristor	LTXL	7%	HSF	dsine MCCB	2200 x 1200 x 1200
LTAPFU3503B2	350	1 x 100 + 3 x 50 + 4 x 25	8	Thyristor	LTXL	7%	HSF	dsine MCCB	2100 x 1600 x 1200
LTAPFU4003B2	400	2 x 100 + 2 x 50 + 4 x 25	8	Thyristor	LTXL	7%	HSF	ACB	2000 x 1800 x 1200
LTAPFU4503B2	450	2 x 100 + 4 x 50 + 2 x 25	8	Thyristor	LTXL	7%	HSF	ACB	2000 x 1800 x 1200
LTAPFU5003B2	500	3 x 100 + 3 x 50 + 2 x 25	8	Thyristor	LTXL	7%	HSF	ACB	2000 x 1800 x 1200

*Actual dimensions will be given in drawings

Major part in the design of APFC panels is the selection of step size of capacitor banks and number of steps. The right selection of step size and number of steps plays a significant role in the performance as well as cost of the APFC panel. This section focuses on the need and ways of good step size (maximum and minimum sizes) selection and number of steps.

1. Maximum Step Size Selection

The maximum capacitor rating in an APFC panel depends upon the following:

- i. Maximum amount of load variation that happens in the industry at a time: Large load variations demand bigger capacitor steps so that target power factor is achieved in short time, by less number of switching operations.
- ii. Current and voltage transient withstand capabilities of the system:
 - Current transients: Switching of big capacitors (usually above 100 kVAR) introduces large magnitude of inrush current (current transients) for a small duration. This results in high thermal and electrical stress on capacitors, short circuit protection devices and mainly, the switching device. This may lead to their nuisance tripping and premature failures
 - Voltage transients: Switching of big capacitors may cause transient over voltages, which might result in failure of sensitive electronic devices

Thus, the maximum size of the capacitor step is a trade-off between the points i and ii. Practically acceptable maximum possible rating in any APFC panel shall be 100 kVAR. If this 100 kVAR rating capacitor is switched using power contactor, the peak inrush current may reach as high as 75 kA. Hence, the capacitors should be switched using either capacitor duty contactors or thyristor switching module.

However, 100 kVAR Capacitor duty contactor can be used for 100 kVAR bank but in case of a thyristor switched panel, thyristor switching module for 100 kVAR rating is not readily available. Hence, the best way to switch a 100 kVAR bank is by connecting two 50 kVAR TSM in parallel, each with a separate physical 50 kVAR capacitor banks. The control supply to both the 50 kVAR TSM shall be common (one relay output of the controller), so that both of the devices are triggered at the same time. To achieve this, the common output of the APFC relay should be programmed as 100 kVAR. Hence, physically they are two separate 50 kVAR banks, whereas electrically they behave as a single 100 kVAR bank.

A sample connection diagram for switching a step of 100 kVAR with 7% Detuned reactor and two TSMs is shown as under:

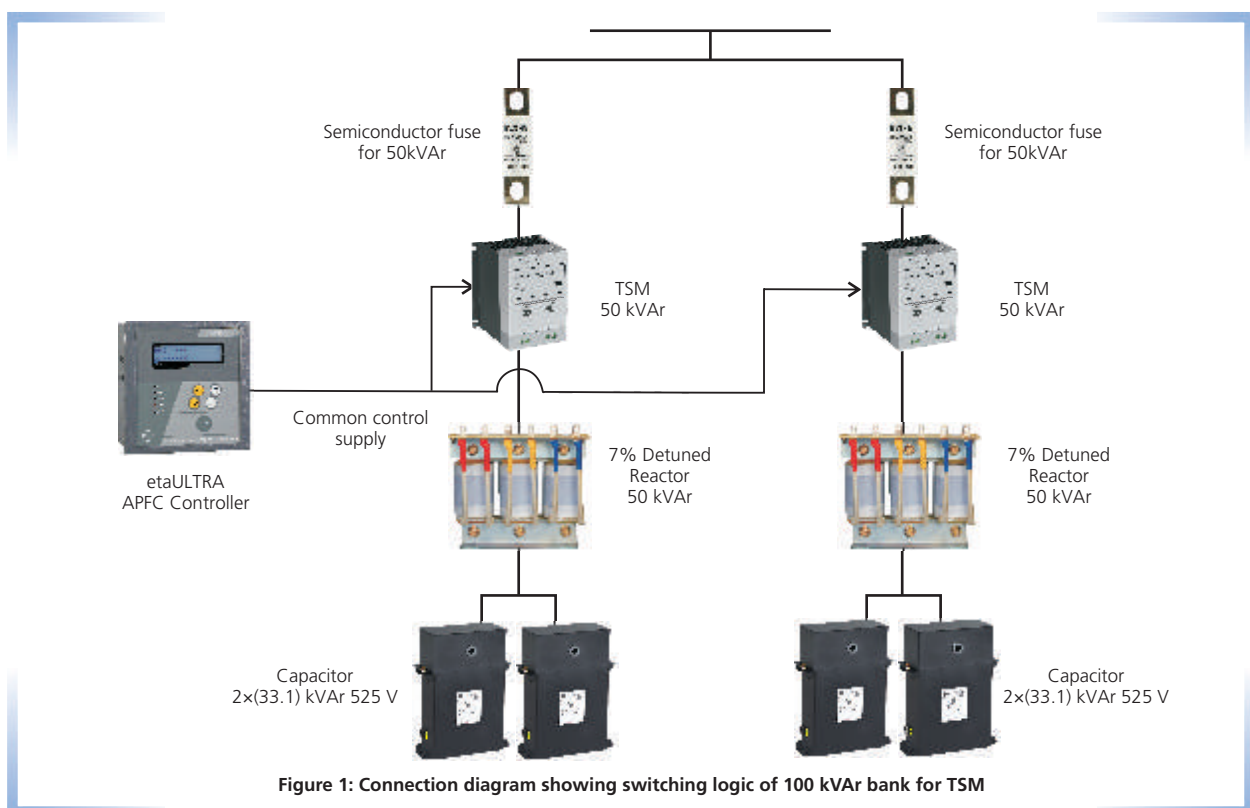

Figure 1: Connection diagram showing switching logic of 100 kVAR bank for TSM

2. Minimum Step Size Selection

The minimum capacitor rating depends on how precise the power factor needs to be maintained. This minimum kVAR rating depends upon the minimum current sensitivity (typically around 2%) of the APFC controller. However the change in PF due to these minimum selected kVAR rating would be usually in the 3rd or 4th decimal places (depending on panel size or kVAR requirement), whereas the electricity board is concerned only with the first two digits of PF (like 0.99).

Typically many industries want the desired target PF to be unity (exactly 1.00), in order to get incentives from some EBs. But practically, the optimum target PF has to be 0.96 to 0.99. These are healthy levels of power factor as it will have safety margin that avoids the leading power factor as well as any dangerous harmonic amplification (due to more capacitance in the system).

Hence, as a rule of thumb, the minimum kVAR rating in an APFC panel can be chosen to be 1-2% of overall rating of APFC panel. For smaller rating APFC panels (up to 100 kVAR), the smallest step can be 2 kVAR and for bigger rating APFC panels (above 600 kVAR and up to 1000 kVAR) the minimum rating can be 25 kVAR.

3. Number of Steps / Branches in APFC Panels

Once the minimum and maximum kVAR rating of the APFC panel is selected, the number of branches can be decided upon based of the following:

- i. Technology of APFC controllers: Latest APFC controllers like etaULTRA Series employ self-optimized intelligent switching where the controller calculates the exact kVAR requirement and switches ON / OFF the appropriate capacitors irrespective of the capacitors already in circuit. Traditional controllers employing linear or circular switching require more number of smaller steps (like 1:2:2:...) for effective power factor correction. Whereas the latest controllers like etaULTRA can have a mix of large and small steps reducing the number of steps in capacitor bank as well as the cost of associated switchgear.
- ii. Size & cost of APFC panel: More the number of steps more will be the cost of APFC panel, due to more number of switchgear, bigger size of panel and others.

An APFC panel should have:

- a. Maximum number of electrical steps (combination of physical steps) to ensure more accurate and flexible power factor correction
- b. Minimum number of physical steps to reduce the size and cost of the panel

Let us consider a few examples of step size selection in APFC panels.

I. 100 kVAR APFC panel

	Case A	Case B
Step configuration	10 + 10 + 10 + 10 + ... 10 times	50 + 25 + 15 + 4 + 2x3
Step resolution	10 kVAR	3 kVAR
Electrical Steps	10, 20, 30, 40, 50, ... 100	3,4,6,7....94,96,97,100
Physical Steps	10	6
No. of Electrical Steps	10	44

In case B, 44 electrical steps are possible with only 6 physical steps; whereas in case A, 10 physical steps are required to achieve 10 electrical steps.

II. 300 kVAR APFC panel

	Case A	Case B
Configuration	25 + 25 + 25 + 25 + ... 12 times	100 + 2x50 + 3x25 + 15 + 10
Step resolution	25 kVAR	10 KVAR
Electrical Steps	25, 50, 75, 100, 125, ... 275, 300	10,15,25,35....285,290,300
Physical Steps	12	8
No. of Electrical Steps	12	36

In Case B, 36 electrical steps are possible with only 8 physical steps; whereas in Case A, 12 physical steps are required to achieve 12 electrical steps

III. 600 kVAR APFC panel

	Case A	Case B
Configuration	50 + 50 + 50 + 50 + ... 12 times	3x100 + 5x50 + 2x25
Step resolution	50 kVAR	25 KVAR
Electrical Steps	50, 100, 150, 200, 250, ... 600	25, 50, 75, 100, 125, ... , 600
Physical Steps	12	10
No. of Electrical Steps	12	24

In Case B, 24 electrical steps are possible with only 10 physical steps; whereas in Case A, 12 physical steps are required to achieve 12 electrical steps.

Summary

- APFC panels with more number of steps (more than 12) does not always mean better step resolution
- With the latest APFC controller technology, fewer steps are sufficient to achieve better step resolution and control of power factor
- Hence, usually a combination of large, small and very small ratings is used in steps of capacitor banks, as given below:
 1. Large rating capacitors (100 kVAr maximum) are required to PF compensation of base load and coarse power factor compensation
 2. Medium rating capacitors are meant for variable part of the reactive power compensation.
 3. Small rating capacitors (usually 1 to 12% of total kVAr or 25 kVAr for panels above 500 kVAr) are meant for fine tuning of the power factor.

Considering the above points, following table suggests optimum number of steps and step sizes from 35 kVAr to 1000 kVAr. Beyond 1000 kVAr, it is always better to split the APFC panels and install them at different PCC/MCC levels.

Panel Rating (kVAr)	Physical Step Size (kVAr)	No. of Physical Steps	Electrical / Logical Steps	No. of Electrical Steps
35	20 + 10 + 2x2 + 1	5	1,2,3,4...33,34,35	23
50	25 + 15 + 5 + 3 + 2	5	2,3,5,10...45,47,48,50	26
75	2x25 + 15 + 5 + 3 + 2	6	2,3,5,7...70,72,73,75	39
100	50 + 25 + 15 + 4 + 2x3	6	3,4,6,7...94,96,97,100	44
125	50 + 2x25 + 15 + 4 + 2x3	7	3,4,6,7...119,121,122,125	55
150	2x50 + 25 + 15 + 4 + 2x3	7	3,4,6,7...144,146,147,150	66
175	2x50 + 2x25 + 10 + 3x5	8	5,10,15,20...165,170,175	35
200	2x50 + 3x25 + 15 + 2x5	8	5,10,15,20...190,195,200	40
225	3x50 + 2x25 + 15 + 10	7	10,15,25,35...210,215,225	27
250	3x50 + 3x25 + 15 + 10	8	10,15,25,35...235,240,250	30
275	4x50 + 2x25 + 15 + 10	8	10,15,25,35...260,265,275	33
300	100 + 2x50 + 3x25 + 15 + 10	8	10,15,25,35...285,290,300	36
350	100 + 4x50 + 25 + 15 + 10	8	10,15,25,35...335,340,350	42
400	2x100 + 2x50 + 4x25	8	25,50,75,100...350,375,400	16
450	2x100 + 3x50 + 4x25	9	25,50,75,100...400,425,450	18
500	2x100 + 5x50 + 2x25	9	25,50,75,100...450,475,500	20
550	3x100 + 3x50 + 4x25	10	25,50,75,100...500,525,550	22
600	3x100 + 5x50 + 2*25	10	25,50,75,100...550,575,600	24
650	4x100 + 3x50 + 4x25	11	25,50,75,100...600,625,650	26
700	4x100 + 5x50 + 2x25	11	25,50,75,100...650,675,700	28
750	5x100 + 3x50 + 4x25	12	25,50,75,100...700,725,750	30
800	5x100 + 5x50 + 2x25	12	25,50,75,100...750,775,800	32
850	6x100 + 3x50 + 4x25	13	25,50,75,100...800,825,850	34
900	6x100 + 5x50 + 2x25	13	25,50,75,100...850,875,900	36
950	7x100 + 3x50 + 4x25	14	25,50,75,100...900,925,950	38
1000	7x100 + 5x50 + 2x25	14	25,50,75,100...950,975,1000	40

The above table is for illustration only, which may be applicable for majority of industries. For accurate compensation, step ratings shall be decided after studying the load profile of the industry.

Disclaimer

For accurate compensation, the load profile of the industry needs to be studied. This gives an indication of the size of peak loads, base loads, possible harmonics, power factor and thus, helps determine step sizes based on load variations. In some cases, the load requirements can also be established from equipment lists.

For any APFC panel, fuses are required for faster short circuit protection and overload protection of capacitors. Fuse selection for capacitive load is critical because of heavy inrush current, high overload capacity and continuous full load. These inherent traits of a capacitor, complicates the selection process. Hence the selection should be such that even during these permissible abnormalities, the fuse should not blow.

Normally, the maximum permissible current in a capacitor branch is 2 times the rated current. This factor is comprised of the following:

- Harmonics overload and over voltage - 30%
- Capacitance tolerance - 10%
- Frequency variation - 2%
- Fuse deration factor - 35%

The fuse used for branch protection must be capable of carrying this current continuously. Hence the fuse should be sufficiently rated so as to avoid the deterioration of the fuse element. Further the fuse should not blow during switching of the capacitors because of the inrush current (more than 100 times the capacitor rated current). In order to prevent nuisance operation of fuse, its time-current characteristic should cover the peak inrush current of the capacitor. Hence for the optimal selection of fuses, the inrush current must be limited by using either capacitor duty contactor or inrush current limiting reactor.

The following table** shows the selection of Fuses and Capacitor switching contactors for an APFC panel:

kVAr	Rated Current* (A)	Derating Factor	Allowed O/C for Capacitor (A)	Recommended Contactor*	Fuse Rating (A)
10	13.12	2	26.24	MO C10	32
15	19.68	2	39.36	MO C15	40
20	26.24	2	52.48	MO C20	63
25	32.80	2	65.60	MO C25	80
50	65.61	2	131.22	MO C50	160

* Selection principle is same for other family of fuses

** The table is valid only for L&T switchgear and capacitors at 440 V

The rated current of a capacitor can be calculated as.

$$\frac{(1000 \times \text{kVAr})}{(\sqrt{3} \times V)}$$

For any capacitor bank, permissible overload is 2 times rated capacitor current. Hence, fuses should be rated to carry continuous overcurrent as given in the above table. In case Thyristor Switching Modules are used instead of capacitor duty contactors, it is highly recommended to use High Speed Fuses (semiconductor fuse).

Above selection chart is valid only if fuses are used along with capacitor duty contactor. Please consider the above table purely as a guideline for selection. Actual selection needs to be done based on considerations of connected load and the electrical network properties.

For any APFC panel, MCCBs are required for short circuit protection, overload protection and for isolation of capacitors. MCCB selection for capacitive load is tricky because of heavy inrush current, high overload capacity and continuous full load. These inherent traits of a capacitor, complicates the selection process. The selection should be such that the MCCB should not nuisance trip during inrush current and should withstand continuous flow of overload current.

Whenever we use MCCB in an APFC panel, proper measures need to be taken against the ill effects of the inrush current. Normally the inrush current (more than 100 times the capacitor rated current) will remain for a few micro-seconds and will not be sensed by the MCCB. However the contacts of MCCB may repel and bounce because of the current limiting feature, causing micro-arcs between the contacts of MCCB. This multiple bounce can result in premature failure of MCCB contacts. In order to reduce the magnitude of the peak inrush current, MCCBs must be used along with capacitor duty contactors or inrush current limiting reactors.

The maximum permissible current in a capacitor branch is 1.46 times the rated current. This factor is comprised of the following:

- Harmonics overload and over voltage - 30%
- Capacitance tolerance - 10%
- Frequency variation - 2%

The branch MCCB must be capable of carrying this current continuously.

The following table** shows the selection of MCCBs and Capacitor switching contactors for an APFC panel:

kVAr	Rated Current*A	Derating Factor	Permissible Capacitor O/L (A)	Recommended Contactor+	MCCB*	Thermal Setting (A)		Magnetic Setting (6 to 10*I _R)
						I _N	I _R (100% I _N)	
10	13.12	1.46	19.16	MO C10	DU / DN / DZ	19	19	171
15	19.68	1.46	28.74	MO C15	DU / DN / DZ	29	29	261
20	26.24	1.46	38.32	MO C20	DU / DN / DZ	38	38	342
25	32.80	1.46	47.90	MO C25	DU / DN / DZ	48	48	432
30	39.37	1.46	57.47	MO C30	DU / DN / DZ	58	58	513
50	65.61	1.46	95.79	MO C50	DU / DN / DZ	96	96	864

* Selection principle is same for other family of MCCBs

**The table is valid only for L&T switchgear and capacitors at 440 V

The rated current of a capacitor can be calculated as

$$\frac{(1000 \times \text{kVAr})}{(\sqrt{3} \times V)}$$

For any capacitor bank, permissible overload is 1.46 times rated capacitor current. Hence, MCCB should be rated to carry continuous over current as given in the above table.

Above selection chart is valid only if MCCB is used along with capacitor duty contactor Please consider the above table purely as a guideline for selection. Actual selection needs to be done based on considerations of connected load and the electrical network properties.

Switchgear and cable selection for capacitor application is quite challenging. The reason is the capacitive networks are more prone to over-current, high peak inrush current and continuous flow of full load current. Usually the capacitors are designed to withstand and operate normally, even during the above said abnormalities, for a finite amount of time. Hence, the switchgear and cables in the capacitor network should be rated accordingly, so as to withstand & operate normally during these abnormalities.

The capacitors draw over-current because of the harmonics, capacitance tolerances, voltage variation and frequency variation. The permitted over-current is up to 146% of the rated current, which comprises the following:

- Harmonics overload and over voltage – 30%
- Capacitance tolerance – 10%
- Frequency variation – 2%

Accordingly, the cables should also be derated, to continuously withstand permitted over-current. The derated cable will also help in withstanding the electrical and thermal stresses that occur during every switching cycle because of high inrush current.

Following is the recommended cable selection chart:

Capacitor Rating (kVAr)	Current at the Rated Voltage (in A)		Derated Current at the Rated Voltage (in A)		Minimum Recommended Copper Cable Size** (sq.mm)
	440 V	415 V	440 V	415 V	
1	1.31	1.39	1.92	2.03	0.5
2	2.62	2.78	3.83	4.06	0.5
3	3.94	4.17	5.75	6.09	0.75
4	5.25	5.56	7.66	8.12	1
5	6.56	6.96	9.58	10.16	1
6	7.87	8.35	11.49	12.19	2.5
7.5	9.84	10.43	14.37	15.23	2.5
8.3	10.89	11.55	15.90	16.86	2.5
10	13.12	13.91	19.16	20.31	4
12.5	16.40	17.39	23.95	25.39	4
15	19.68	20.87	28.74	30.47	6
20	26.24	27.82	38.32	40.62	10
25	32.80	34.78	47.90	50.78	16*
50	65.61	69.56	95.79	101.56	35
75	98.41	104.34	143.69	152.34	70
100	131.22	139.12	191.58	203.12	95

**Cross section values mentioned above are guidelines that are valid for operation under normal conditions and at ambient temperature of 40°C.

*Use spreader while using 16 sq.mm cable

Busbar selection in APFC panels can be done with the standard calculations for short circuit withstand capability and temperature rise (current density). The only assumption is that the rated current should be considered as 146% of the total capacitor rated current.

It is recommended to use capacitor duty contactors to reduce the magnitude of peak inrush current. This will reduce the thermal and electrical stress in the capacitors, cables and switchgear, which happens during each switching cycle. This also prevents the premature failure of capacitors and nuisance tripping of short circuit protection device. The above special selection for cables will also overcome the heating and losses that happen because of skin effect.

The life of the power capacitors and other equipment in APFC panels depend very much on the operating temperature. In panels with detuned harmonic filter reactors and thyristor switches, the chances of elevated temperature are high, as these equipments generate relatively more heat.

Hence in order to maximise the life of the capacitors and other important equipments in the APFC panel, the temperature must not be allowed to increase beyond certain limit. This section briefs some guidelines about the thermal design of APFC panels and thereby managing the heat effectively.

For any panel, the temperature rise can be reduced by the following three ways:

- Operating at lower ambient temperature
- Using devices with lower power loss
- Dissipating the excess heat, so that temperature rise is controlled

There is minimal control over the first two conditions. But the third condition completely depends upon the design of the panel. By offering effective cooling methods, the excess heat generated by the equipments can be dissipated.

Selection of the cooling methods can be decided based on the internal temperature rise inside the panel. The maximum internal temperature can be calculated using the following formula:

$$\text{Internal Temperature } (T_i) = \frac{P_d}{k \times S} + T_a$$

Where, P_d = Total power dissipated in the panel (in watts)
 k = constant defined by the material used to manufacture the enclosure
 For painted sheet-steel enclosure, $k = 5.5 \text{ W/m}^2 \text{ }^\circ\text{C}$
 S = effective surface area of the panel (in m^2)
 T_a = Ambient temperature (in $^\circ\text{C}$)

If the temperature rise ($T_i - T_a$) is within the acceptable limits, natural cooling would be sufficient; else forced cooling method should be employed for dissipating excessive heat.

1. Natural Cooling

In most of PCCs and MCCs, the temperature rise remains under desirable limits with natural circulation of air (through natural convection and radiation). The air circulation happens through some slots in the enclosure, called the louvers. When temperature rises inside the panel, the pressure of the air increases and the density reduces.

Hence the hot air tends to move upwards. The hot air would go out through the louvers provided at the top side of the panel. Fresh cold air would enter the panel through the louvers provided at the bottom. This is represented in Figure 1.

Figure 2 represents the common usage of extra louvers in-between the top and bottom louvers.

The common misconception behind this is that, extra louver would increase the volume of air flow. Practically, this does not happen because the volume of the panel is fixed.

This results in the reduced air flow at the bottom section of the panel, as some air enters through the middle louvers. Hence, the temperature of the lower section of the panel will be higher than the upper section.

It is recommended to follow the panel design as per the Figure 1.

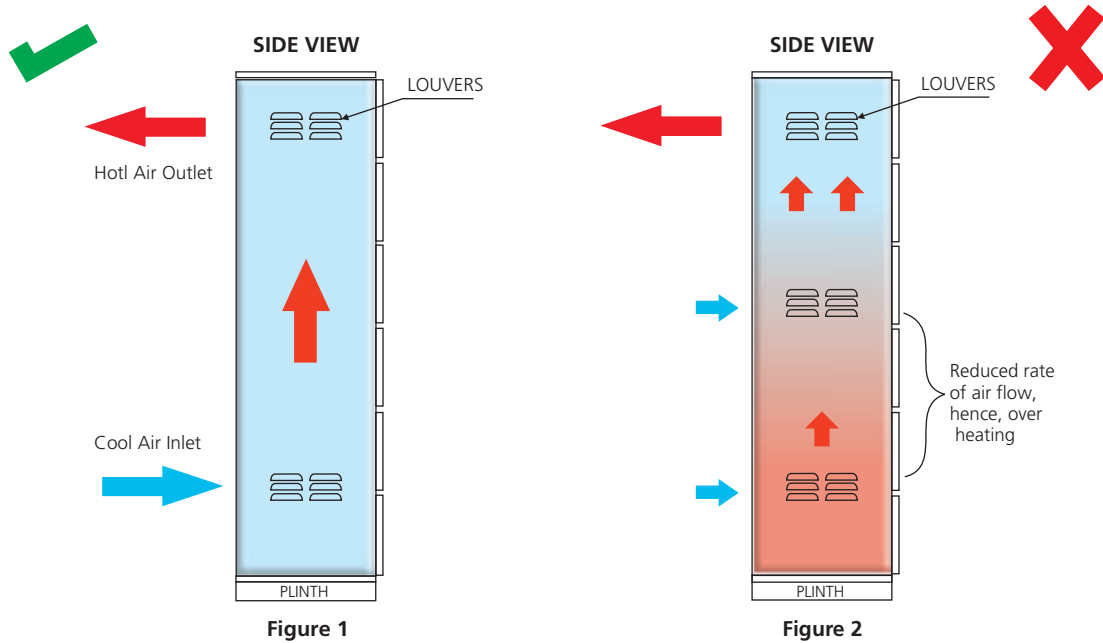

2. Forced Cooling

In most of the APFC panels and in some MCC and PCC panels, the above method would not offer sufficient cooling. In order to maintain the desired temperature levels (ambient temperature + allowed temperature rise), forced cooling methods (using fans at the top) should be employed, which would increase the rate of air flow.

In Figure 3 the cold air enters through the bottom louvers, flows through all the equipments and they are forced out of the panel through fans. Hence, temperature rise in the panel is kept under check and there are no hot spots/sections.

In Figure 4 provision of additional louvers, actually disturbs the uniformity of the flow. Major chunk of cold air would enter through the top louver and result in "short cycling". So the bottom section of the panel would see higher temperature rise.

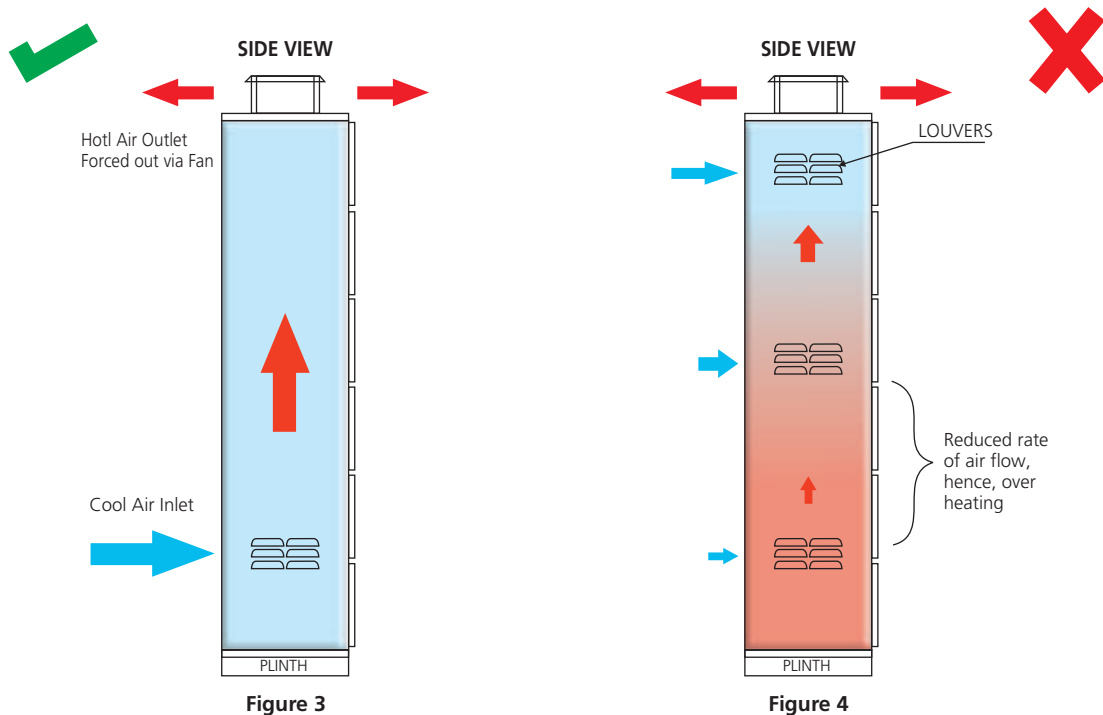

2.1 Fan Selection for Forced Cooling

Fan selection is based on the rate of air flow, which is measured in m³/h or Cubic Feet per Minute (CFM), where 1 CFM = 1.7 x 1 m³/h. Following is the formula to calculate air flow rate:

$$Q = C_x \frac{P_d - [k \times S (T_d - T_a)]}{(T_d - T_a)}$$

Where,

Q = Air flow rate (in m³/h)

C = Coefficient related to the altitude above the sea level







Altitude (in meters)	C
0 to 100	3.1
101 to 250	3.2
251 to 500	3.3
501 to 750	3.4
751 to 1000	3.5

P_d = total power loss (watts) inside the panel, by summing up the power loss of individual devices like capacitors, reactors, thyristor switches, contactors, bus bars, joints and so on.

k = constant defined by the material used to manufacture the enclosure.

For painted sheet-steel enclosure, k = 5.5 W/m² °C

S = Open surface area of the panel (in sq. m) can be calculated using one of the below formulas:

Position of the Enclosure	Formula for Calculating S (in sq. m) as per IEC 890
 accessible on all sides	$S = 1.8 \times H \times (W + D) + 1.4 \times W \times D$
 placed against a wall	$S = 1.4 \times W \times (H + D) + 1.8 \times D \times H$
 end of a row of enclosures	$S = 1.4 \times D \times (H + W) + 1.8 \times W \times H$
 end of a row of enclosures with back against the wall	$S = 1.4 \times H \times (W + D) + 1.4 \times W \times D$
 intermediate in a row of enclosures	$S = 1.8 \times W \times H + 1.4 \times W \times D + D \times H$
 intermediate in a row of enclosures with the back against the wall	$S = 1.4 \times W \times (H + D) + D \times H$
 intermediate in a row of enclosures back against the wall with top part covered	$S = 1.4 \times W \times H + 0.7 \times W \times D + D \times H$

T_d = Desired Maximum temperature inside the enclosure

T_a = Ambient temperature

This is a simple method of thermal management and fan selection, which is suitable for majority of the panels. At the same time, some other aspects like position of mounting various equipments in the APFC panel should be taken care. Some of them are as follows:

- Capacitors should be kept below the reactors, which are the major heat sources. This is because the elevated temperature would reduce the life of the capacitors.
- The reactors should be mounted in the zigzag position (as shown in the below figure), in order to ensure better heat flow. If the reactors are kept one above other, the bottom most reactors would heat up the other reactors that are mounted above them.
- Thyristor switching modules should be mounted vertically (position of heat sink should be parallel to the air flow direction) and in zigzag positions. The TSM panel should be non-compartmentalized design for better heat dissipation.
- Reactors & capacitors should be mounted over channels to allow the free flow of air. Flat base plates are not recommended.
- The panel should not be compartmentalized. Compartmentalised design would lead to heat accumulation in the panel.
- For Reactors and TSM, a clearance of 100 mm should be maintained in all directions.

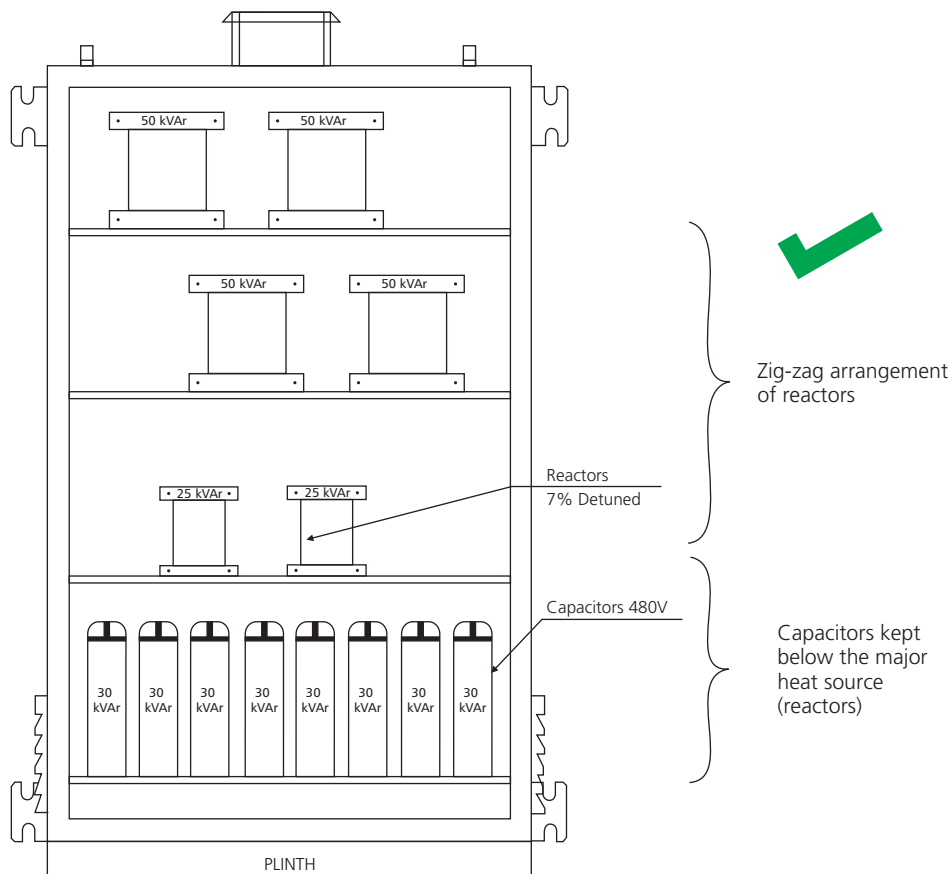

Hence, in APFC panels, a proper thermal design would pave way for maximising the life of important equipments like capacitors, thyristor switches, reactors and other switchgear.

etaPRO is an innovative, multi-utility and user friendly software package, related to Reactive Power Management. The users will get the benefit of easy and error free selection of products.



Features



■ KVAR CALCULATION

Easy calculation of capacitor kVAR rating if initial power factor and final power factor are known



■ DETUNED HARMONIC FILTER SELECTION

Selection of right capacitor-reactor combination (detuned harmonic filter) and the catalogue numbers

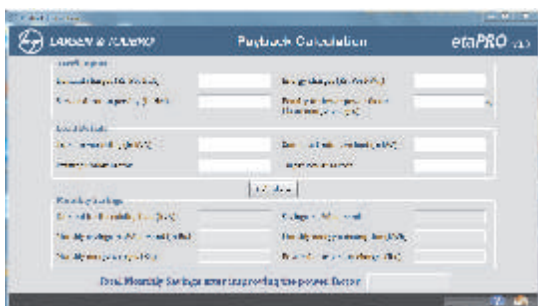

■ PAYBACK CALCULATION

Monthly payback calculation, after improving the power factor to the desired level

■ APFC PANEL BILL OF MATERIALS GENERATION

Generation of bill of materials, covering capacitor selection, switchgear selection, switching device selection. The output gives the catalogue numbers and MRP of all the items in the panel, that can be exported to excel format.

- BoM generation up to 1600 kVAr APFC Panels with maximum 16 steps
- Auto-calculation of rated incomer and branch currents
- Switchgear selection options for main incomer (ACB, MCCB and SDF) and branch protection (MCCB, SDF, HRC Fuse and MCB)
- Accessories selection for the selected switchgear
- Capacitors and reactor selection
- Instant catalogue access for selected switchgear/capacitors
- Final BoM in two forms:
 - Branch-wise list of items
 - Consolidated list of items

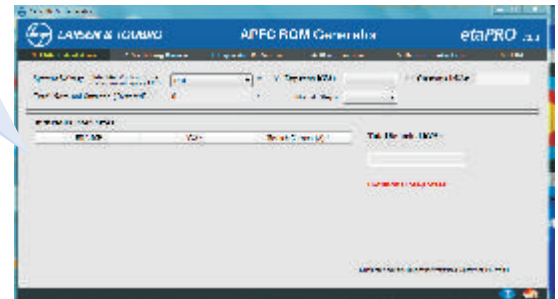

■ AHF selection

Selection of right Ampere rated Active Harmonic Filter to eliminate harmonics and enhance power quality

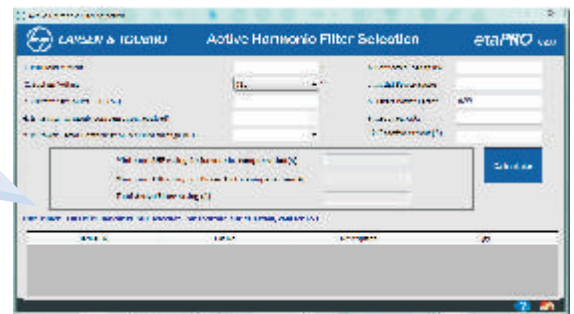

■ TECHNICAL ARTICLES AND PRESENTATIONS

Technical articles related to Power Quality Solutions



Benefits

End customers and panel builders will be benefitted by the following ways:

- Easy selection of capacitors and reactors
- Error free switchgear ratings selection
- Time saving while preparing APFC quotations
- Optimum step size selection
- Automatic selection of capacitor-reactor combinations
- BoM can be exported to Microsoft Excel format

Get the Switchgear Training Edge!

Aimed at maximizing productivity, conserving energy, minimizing costs and enhancing safety, our Electrical & Automation training programmes have benefitted over 1.77 Lakh professionals in the last 30 years. These training programmes are highly beneficial as they provide right exposure and impart knowledge on selection, installation, maintenance and testing of Electrical & Automation Products.

So gain the advantage and go the extra mile with:

- 14 courses on contemporary topics
- Courses applicable to all switchgear brands
- Training Centers in Pune, Lucknow, Coonoor, Vadodara, Delhi & Kolkata
- Blend of theory and practical experience

The typical training programmes cover:

- Low Voltage & Medium Voltage Switchgear
- Switchboard Electrical Design
- AC Drives & Building Management Solutions
- Protective Relays & Earthing
- Power Quality Solutions

Please contact any of the training centres for participation and detailed training programme schedule.



Pune
L&T Electrical & Automation
Switchgear Training Centre,
T-156/157, MIDC
Bhosari,
Pune - 411 026
Tel: 020 2712 0037 / 2712 0653
Fax: 020 2712 2933
E-mail: stc-pune@Lntebg.com



Lucknow
L&T Electrical & Automation
Switchgear Training Centre,
C - 6 & 7, UPSIDC
P. O. Sarojinagar,
Lucknow - 226 008
Tel: 0522 247 6015 / 97944 54455
Fax: 0522 247 6015
E-mail: stc-lucknow@Lntebg.com



Coonoor
L&T Electrical & Automation
Switchgear Training Centre,
Ooty-Coonoor Main Road
Yellanahalli P.O.,
The Nilgiris - 643 243
Tel. : 0423 251 7107
Fax : 0423 251 7158
E-mail: stc-coonoor@Lntebg.com



Vadodara
L&T Electrical & Automation
Switchgear Training Centre
Behind L&T Knowledge City,
Near Village Ankhoh,
Vadodara - 390019
Tel: 0265 2457805
E-mail: stc-vadodara@Lntebg.com



Delhi
L&T Electrical & Automation
Switchgear Training Centre
32, Shivaji Marg,
Near Motinagar Metro Station,
New Delhi - 110015
Tel: 011 41419515 / 41419695 / 41419500
Fax: 011 41419600
E-mail: stc-delhi@Lntebg.com



Kolkata
L&T Electrical & Automation
Switchgear Training Centre
4th Floor, 3B, Shakespeare Sarani,
Kolkata - 700071
Tel: 033 42005975 / 42005978
E-mail: stc-kolkata@Lntebg.com

Electrical Standard Products (ESP) Offices:

HEAD OFFICE

L&T Electrical & Automation
L&T Business Park, TC 2, Tower 'B'
3rd Floor, Gate No 5
Saki Vihar Road, Powai
Mumbai 400 072
Tel: 022-67052874 / 2737 / 1156
e-mail: cic@LNTEBG.com

BRANCH OFFICES

L&T Electrical & Automation
501, Sakar Complex I
Opp. Gandhigram Rly. Station
Ashram Road
Ahmedabad 380 009
Tel: 079 4900 4000 / 4010
e-mail: esp-ahm@LNTEBG.com

L&T Electrical & Automation
No 38, Cubbon Road
Bengaluru 560 001
Tel: 080-46136103 / 100
e-mail: esp-blr@LNTEBG.com

L&T Electrical & Automation
131/1, Zone II, Maharana Pratap Nagar
Bhopal 462 011
e-mail: esp-bho@LNTEBG.com

L&T Electrical & Automation
Plot No. 559, Annapurna Complex, 2nd Floor
Lewis Road
Bhubaneswar 751 014
Tel: 0674-2436690 / 9437453579 / 9437284376
e-mail: esp-bsr@LNTEBG.com

L&T Electrical & Automation
Aspire Towers, 4th Floor
Plot No. 55, Phase-I
Industrial & Business Park
Chandigarh 160 002
Tel: 0172-4646840 / 41 / 42 / 44 / 53
e-mail: esp-chd@LNTEBG.COM

L&T Electrical & Automation
L&T Construction Campus
TC-1 Building, II Floor
Mount-Poonamallee Road
Manapakkam
Chennai 600 089
Tel: 044-2270 6800
e-mail: esp-maa1@LNTEBG.com

L&T Electrical & Automation
Electrical Standard Products
Manufacturing Facility
L&T Bypass Road, Malumichampatti
Coimbatore 641 050
Tel: 0422-6683031
e-mail: esp-cbe@LNTEBG.com

L&T Electrical & Automation
3rd Floor, 1&2 Vijay Park,
Main Chakrata road
Ballapur Chowk
Dehradun 248001
Tel: +91 9582252411

L&T Electrical & Automation
Khairasol, Degaul Avenue
Durgapur 713 212
Tel: 0343-2540448 / 2540449 / 2540443
e-mail: esp-dgp@LNTEBG.com

L&T Electrical & Automation
5, Milanpur Road, Bamuni Maidan
Guwahati 781 021
Tel: +91 8876554417
e-mail: esp-ghy@LNTEBG.com

L&T Electrical & Automation
2nd Floor, Vasantha Chambers
5-10-173, Fateh Maidan Road
Hyderabad 500 004
Tel: 040-67015052
e-mail: esp-hyd@LNTEBG.com

L&T Electrical & Automation
Monarch Building, 1st Floor
D-236 & 237, Amrapali Marg
Vaishali Nagar
Jaipur 302 021
Tel: 0141-4385914 to 18
e-mail: esp-jai@LNTEBG.com

L&T Electrical & Automation
Akashdeep Plaza, 2nd Floor
P. O. Golmuri
Jamshedpur 831 003
Jharkhand
Tel: 0657-2340502 / 08
e-mail: esp-jam@LNTEBG.com

L&T Electrical & Automation
Skybright Bldg; M. G. Road
Ravipuram Junction, Ernakulam
Kochi 682 016
Tel: 0484-4409420 / 4 / 5 / 7
e-mail: esp-cok@LNTEBG.com

L&T Electrical & Automation
3-B, Shakespeare Sarani
Kolkata 700 071
Tel: 033-48006001
e-mail: esp-kol@LNTEBG.com

L&T Electrical & Automation
No. 10, Fortuna Tower, 2nd Floor
Rana Pratap Marg, Near NBRI
Lucknow 226001
e-mail: esp-Lko@LNTEBG.com

L&T Electrical & Automation
No: 73, Karpaga Nagar, 8th Street
K. Pudur
Madurai 625007
Tel: 0452-2567405 / 2561068 / 2561657
e-mail: esp-mdu@LNTEBG.com

L&T Electrical & Automation
L&T Business Park, TC 2, Tower 'B'
3rd Floor, Gate No 5
Saki Vihar Road, Powai
Mumbai 400 072
Tel: 022-67052874 / 2737 / 1156
e-mail: esp-bom@LNTEBG.com

L&T Electrical & Automation
Unnati Building, 2nd Floor
Automation Campus
A-600, TTC Industrial area
Shil-Mahape road, Mahape
Navi Mumbai 400710
Tel: +91 22 67226502 / 67226300

L&T Electrical & Automation
12, Shivaji Nagar
North Ambajhari Road
Nagpur 440 010
Tel: 0712-2260012 / 6606421
e-mail: esp-nag@LNTEBG.com

L&T Electrical & Automation
A-25, Imperia Complex, First Floor,
Mohan Cooperative Industrial Estate,
Near Sarita Vihar Metro Station,
Mathura Road
New Delhi 110 044
Tel: 011-41419514 / 5 / 6
e-mail: esp-del@LNTEBG.com

L&T Electrical & Automation
Grand Chandra, 2nd Floor
Fraser Road
Opposite Doordarshan Kendra
Patna 800001
e-mail: esp-patna@LNTEBG.com

L&T Electrical & Automation
L&T House
P. O. Box 119
191/1, Dhole Patil Road
Pune 411 001
Tel: 020-48544395 / 48544279
e-mail: esp.pnq@LNTEBG.com

L&T Electrical & Automation
Crystal Tower,
4th Floor, G. E. Road
Telibandha
Raipur 492 006
Tel: +91 9755508228
e-mail: esp-raipur@LNTEBG.com

L&T Electrical & Automation
3rd Floor
Vishwakarma Chambers
Majura Gate, Ring Road
Surat 395 002
Tel: 0261-2473726
e-mail: esp-sur@LNTEBG.com

L&T Electrical & Automation
Radhadaya Complex
Old Padra Road
Near Charotar Society
Vadodara 390 007
Tel: 0265-6613610 / 1 / 2
e-mail: esp-bar@LNTEBG.com

L&T Electrical & Automation
Door No. 49-38-14/3/2, 1st floor,
NGGO's Colony, Akkayyapalem,
Visakhapatnam 530 016
Tel: 0891-2791126 / 2711125
e-mail: esp-viz@LNTEBG.com

Product improvement is a continuous process. For the latest information and special application, please contact any of our offices listed here. Product photographs shown for representative purpose only.



L&T Electrical & Automation, Electrical Standard Products

L&T Business Park, TC-2, Tower B, 3rd Floor, Gate No. 5, Saki Vihar Road, Powai,
Mumbai - 400 072, INDIA www.lntebg.com

Customer Interaction Center (CIC)

BSNL / MTNL (toll-free): 1800 233 5858 Reliance (toll-free): 1800 200 5858
Tel: 022 6774 5858 Email: cic@lntebg.com Web: www.lntebg.com