



Soft Starters



L&T Electrical & Automation, India's leading manufacturer of low tension switchgear, introduces a new range of Soft Starters- SUPERNOVA. The range extends from simple soft start control devices to advanced systems that match complex requirements.

SUPERNOVA Series

Range of Soft Starters

CSX Series Soft Starters provide soft start and soft stop control for new or existing motor control centers. These starters are compact and include a built-in bypass contactor to eliminate heat dissipation during run. This makes the CSX Series ideal for installation into switchboards or starter enclosures.

CSXi Series Soft Starters have a comprehensive motor starting and protection system with a built-in bypass contactor. In addition to constant current start control, CSXi soft starters provide advanced motor thermal modeling and a range of protection functions.

EMX3 Series Soft Starters come with total motor starting solution, combining high-level functionality with flexibility and ease of use. For advanced applications, an extensive range of functions makes the EMX3 suitable for nearly all motor starting and control requirements.



- Compact design, small footprint
- Built-in bypass contactor
- Easy installation and operation
- Complements existing motor protection
- Ratings from 7.5kW to 110kW



FEATURES

	CSX
Starting	
Timed voltage ramp (TVR)	✓
Stopping	
Soft stop	✓
Protection	
Supply fault	✓
Shorted SCR	✓
LED Indication	
Ready/Tripped	✓
Running/Starting-Stopping	✓
Fault code	✓
Relay Outputs	
Main contactor	✓
Options & Accessories	
Remote Operator	✓
PC Software	✓
Modbus RTU	✓
Profibus	✓
Device Net	✓
Finger Guard Kit	✓

SPECIFICATIONS

Motor kW	Current Rating (Maximum Motor FLC)		Dimensions (mm)		
	AC53b 4-6:354	AC53b 4-20:340	Width	Height	Depth
7.5	18 A	17 A	98	203	165
15	34 A	30 A			
18.5	42 A	36 A			
22	48 A	40 A			
30	60 A	49 A			
	AC53b 4-6:594	AC53b 4-20:580			
37	75 A	65 A	145	215	193
45	85 A	73 A			
55	100 A	96 A			
75	140 A	120 A	202	240	214
90	170 A	142 A			
110	200 A	165 A			

Ratings

Current Range	18A ~ 200A, AC53b
Supply Voltage	200 ~ 440VAC or 200 ~ 575VAC
Supply Frequency	45 to 66Hz
Control Voltage	110 or 230 ~ 440 VAC (+ 10% / -15%) 24VAC / VDC (± 20%)
Enclosure	IP20 up to 55kW IP00 for 75kW and above
Approvals	CE

SCHEMATICS

CSX installed with motor protection circuit breaker

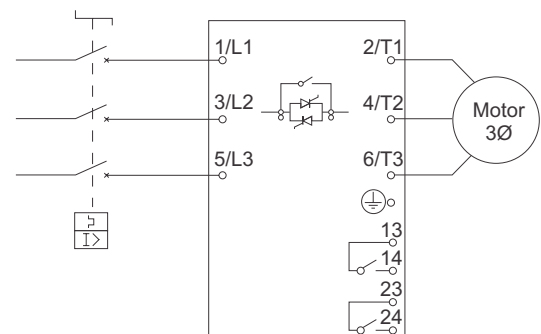

CSX installed with a moulded case circuit breaker, separate overload relay and line contactor

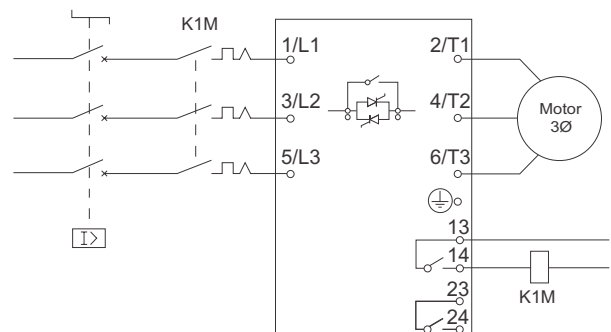

Note: Use semiconductor fuses at input

CSXi

Soft Starters

- Compact design, with built-in bypass contactor
- Essential motor protection
- Selectable soft starting profiles
- Flexible communication options
- Ratings from 7.5kW to 110kW

FEATURES

CSXi	
Starting	
Constant current	✓
Current ramp	✓
Stopping	
Soft stop	✓
Protection	
Instantaneous over current	✓
Bypass overload	✓
Motor overload	✓
Phase imbalance	✓
Phase sequence	✓
Excess start time	✓
Motor thermistor	✓
Supply fault	✓
Shorted SCR	✓
LED Indication	
Ready/Tripped	✓
Running/Starting-Stopping	✓
Fault code	✓
Relay Outputs	
Main contactor	✓
Run	✓
Tripped	✓
Options & Accessories	
Remote Operator	✓
PC Software	✓
Modbus RTU	✓
Profibus	✓
Device Net	✓
Finger Guard Kit	✓

Ratings

Current Range	18A ~ 200A, AC53b
Supply Voltage	200 ~ 440VAC or 200 ~ 575VAC
Supply Frequency	45 to 66Hz
Control Voltage	110 or 230 ~ 440 VAC (+ 10% / -15%) 24VAC / VDC (± 20%)
Enclosure	IP20 up to 55kW IP00 for 75kW and above
Approvals	CE

Note: Use semiconductor fuses at input

SPECIFICATIONS

Model kW	Current Rating (Maximum Motor FLC)		Dimensions (mm)		
	AC53b 4-6:354	AC53b 4-20:340	Width	Height	Depth
7.5 15 18.5 22 30	18 A 34 A 42 A 48 A 60 A	17 A 30 A 36 A 40 A 49 A	98	203	165
37 45 55	AC53b 4-6:594	AC53b 4-20:580	145	215	193
75 90 110	140 A 170 A 200 A	120 A 142 A 165 A	202	240	214

SCHEMATICS

CSXi installed with moulded case circuit breaker with shunt trip device

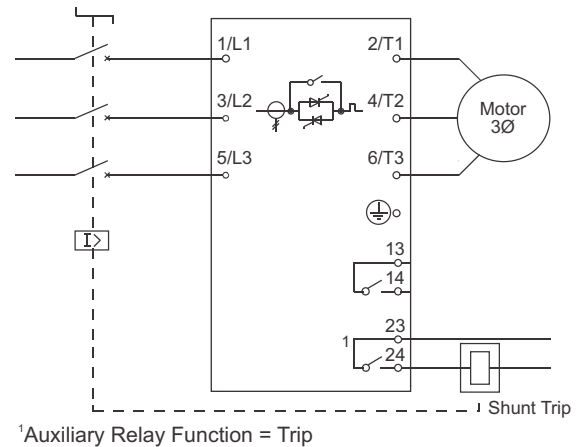

CSXi installed with moulded case circuit breaker with line contactor

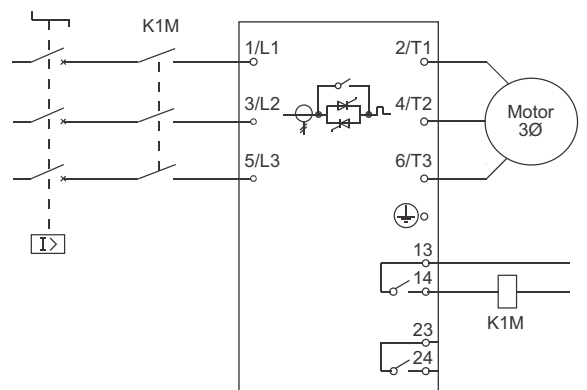

CSX & CSXi

Selection Chart



CSX	CSXi	Motor Rating		AC-53b 4-6:354		AC-53b 4-20:340	
		(kW)	(HP)	40°C	50°C	40°C	50°C
CSX0007V4C1	CSXi0007V4C1	7.5	10	18A	17A	17A	15A
CSX0015V4C1	CSXi0015V4C1	15	20	34A	32A	30A	28A
CSX0018V4C1	CSXi0018V4C1	18	25	42A	40A	36A	33A
CSX0022V4C1	CSXi0022V4C1	22	30	48A	44A	40A	36A
CSX0030V4C1	CSXi0030V4C1	30	40	60A	55A	49A	45A
				AC-53b 4-6:594		AC-53b 4-20:580	
				40°C	50°C	40°C	50°C
CSX0037V4C1	CSXi0037V4C1	37	50	75A	68A	65A	59A
CSX0045V4C1	CSXi0045V4C1	45	60	85A	78A	73A	67A
CSX0055V4C1	CSXi0055V4C1	55	75	100A	100A	96A	87A
CSX0075V4C1	CSXi0075V4C1	75	100	140A	133A	120A	110A
CSX0090V4C1	CSXi0090V4C1	90	120	170A	157A	142A	130A
CSX0110V4C1	CSXi0110V4C1	110	150	200A	186A	165A	152A

Ordering Information

CSX ■ ■ ■ V ■ C ■

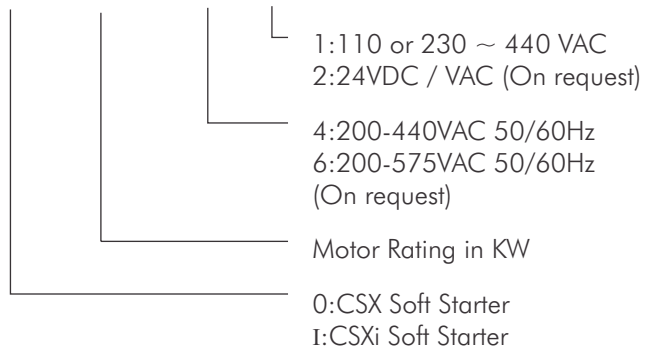

EMX3

Digital Soft Starters

The EMX3 is the latest development in soft starter technology providing a complete motor starting and management system. With an impressive range of features in a single user friendly package, never before has motor control been so simple.

- Advanced soft start and soft stop control
- Protection functions operate even when bypassed
- External input/outputs for remote management
- Fully programmable auto start and auto stop
- LCD display for programming & monitoring

FEATURES

EMX3	
Starting Functions	
XLR-8 adaptive acceleration	✓
Constant current start mode	✓
Current ramp start mode	✓
Kickstart	✓
Stopping Functions	
XLR-8 adaptive deceleration	✓
TVR soft stop	✓
Brake mode	✓
Coast to stop	✓
Keypad	
Large LCD screen	✓
Remote Mounting option	✓
Status LED's	✓
Easy to read screen	✓
Real language feedback	✓
Multi-language options	✓
Shortcut button	✓
Protection	
Fully customisable protection	✓
Motor thermal model	✓
Motor thermistor input	✓
Phase sequence	✓
Undercurrent	✓
Instantaneous overcurrent	✓
Auxiliary trip input	✓
Heatsink overtemperature	✓
Excess start time	✓
Supply frequency	✓
Shorted SCR	✓
Power circuit	✓
Motor connection	✓
RS485 failure	✓
Motor overload	✓
Current imbalance	✓
Ground fault(optional)	✓



EMX3	
Control Interface	
Control inputs(3 x fixed, 2 x programmable)	✓
Motor thermistor input	✓
PT100 RTD input	✓
Relay outputs(1 x fixed, 3 x programmable)	✓
Analogue output (1 x programmable)	✓
Serial output(1 x RS485)	✓
Additional Features	
Starter communication timeout	✓
Network communication trip	✓
Auto detection of inline or inside delta power connection	✓
Programmable auto start/stop	✓
24 VDC auxiliary power supply	✓
PT 100 (RTD) input	✓
Real time clock with battery backup	✓
Powerthrough - enables the choice of continuous operation despite a power assembly failure.	✓
Forward and reverse jog function	✓
I/O expansion card (optional)	✓
Approvals	
CE	✓

EMX3

Acceleration Control



ADAPTIVE ACCELERATION PROFILE OPTIONS

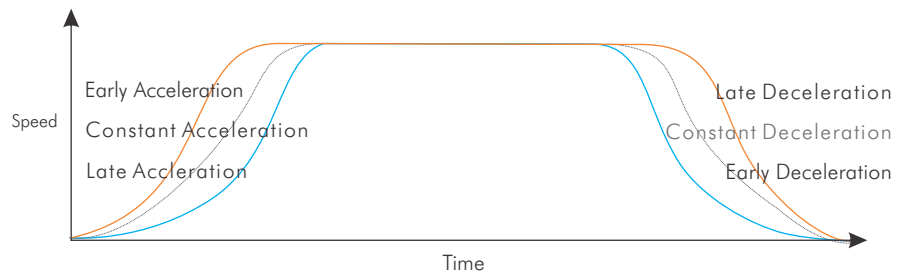

Adaptive acceleration offers threestop profiles according to your needs.

XLR-8 ADAPTIVE ACCELERATION CONTROL

L&T Electrical & Automation's new EMX3 soft starter introduces a new generation in soft start technology XLR-8 Adaptive Acceleration Control. XLR-8 gives you an unprecedented level of control over your motor's acceleration and deceleration profiles. Using XLR-8, the soft starter learns your motor's performance during start and stop, then adjusts control to optimise performance. Simply select the profile that best matches your load type and the soft starter automatically ensures the smoothest possible acceleration for your load.

SMARTER STARTING

The EMX3 puts you in control of motor starting. Depending on your application requirements you can select the best soft start control method.

For applications requiring precise control of motor start current the EMX3 offers a choice of Constant Current or Current Ramp start modes. For superior control over acceleration or deceleration choose Adaptive Acceleration Control.

SMOOTHER STOPPING

Adaptive Acceleration Control also provides precise control over soft stopping and is ideal for applications requiring a smoother soft stop. It is ideal for low inertia loads such as pumps and conveyors, and can substantially reduce or eliminate the effects of water hammer.

SIMULATIONS

Need to test the installation before connecting a motor? The EMX3 simulation functions let you test the soft starter's operation, external control circuits and associated equipment without connecting the soft starter to line voltage or a motor. The EMX3 has three simulation modes:

Run simulation:

Simulates a motor starting, running and stopping to ensure correct installation.

Protection simulation:

Simulates activation of each protection mechanism to confirm correct protection response.

Signalling simulation:

Simulates output signalling.



EMX3

Wiring Schematics

In-line installation, internally bypassed

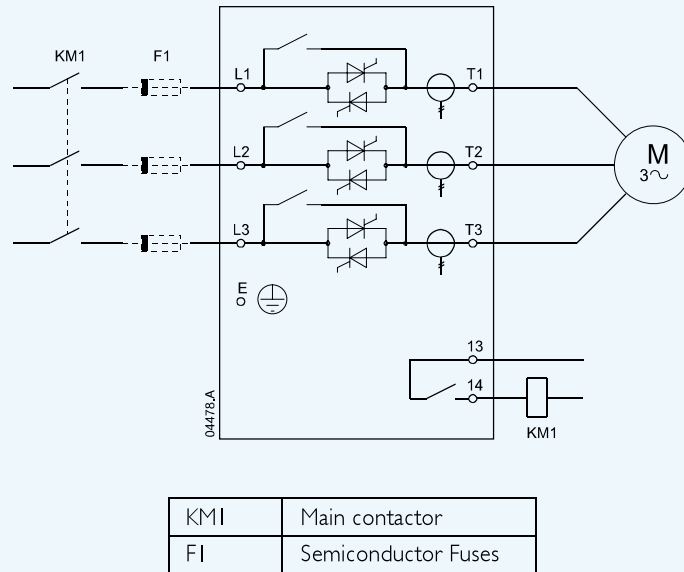

In-line installation, externally bypassed

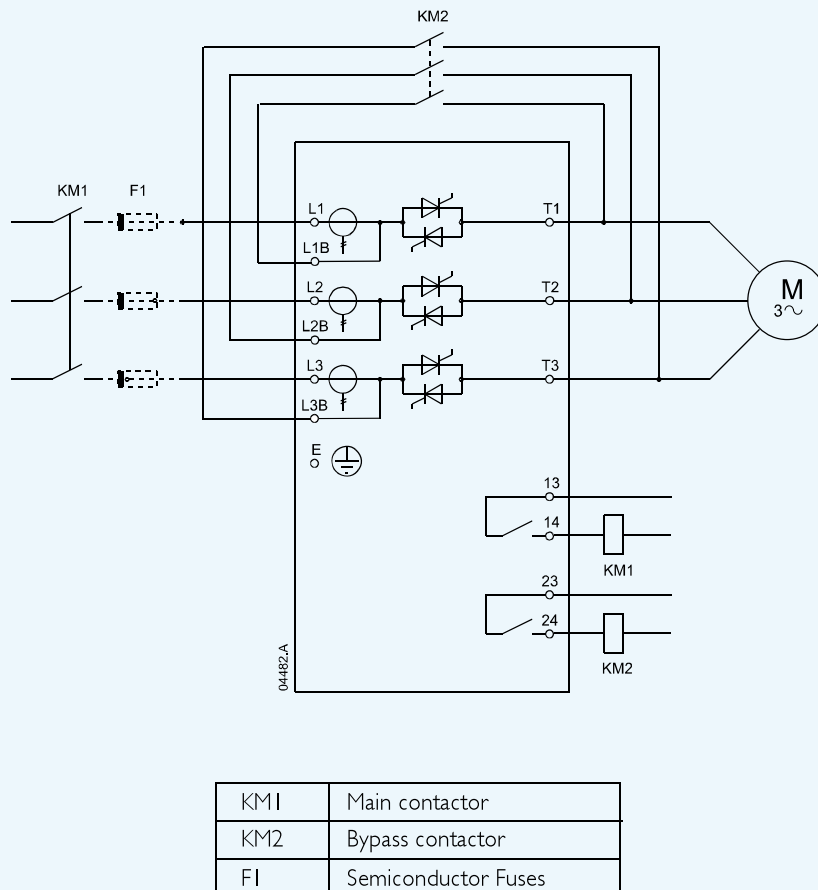

Inside delta installation, internally bypassed

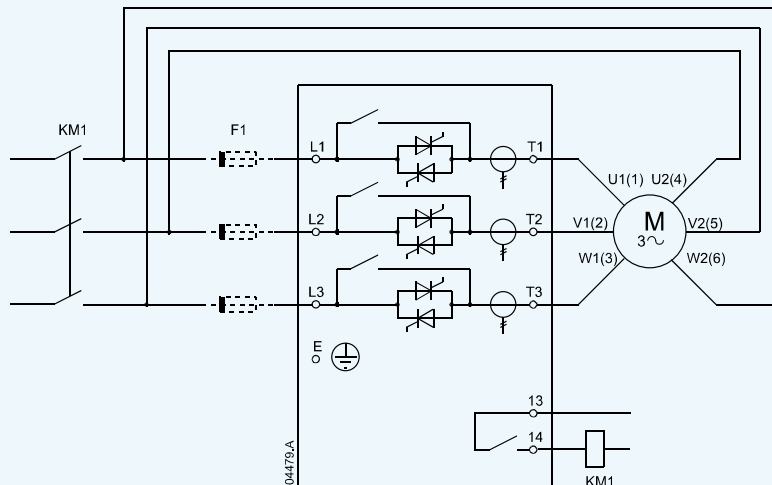

KM1	Main contactor
F1	Semi-conductor Fuses

Inside delta installation, externally bypassed

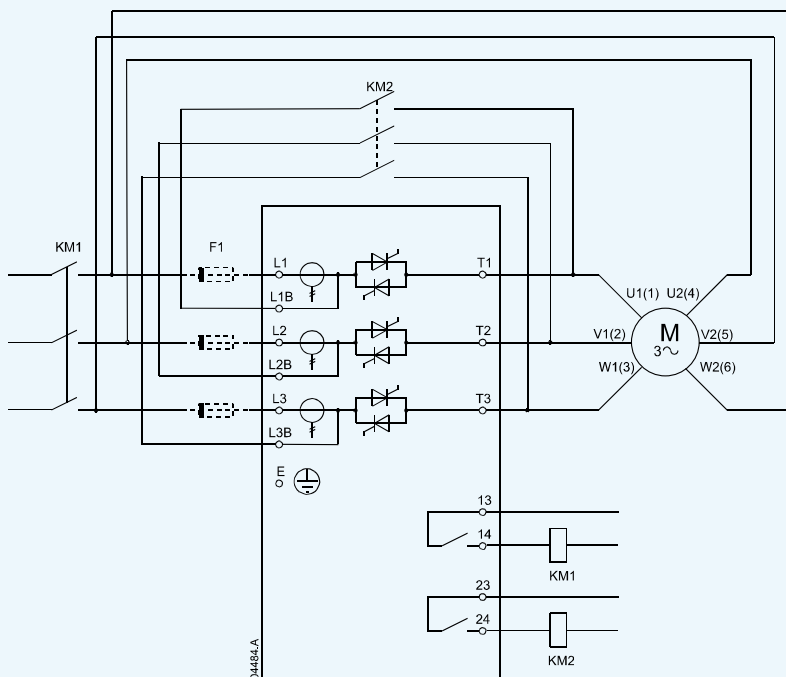

KM1	Main contactor
KM2	Bypass contactor
F1	Semiconductor Fuses

EMX3

Specifications

General

Current Range..... 23A ~ 1600A(nominal)
 Motor Connection..... In-Line or inside delta
 By pass..... Integrated internal or external

Supply

Mains Voltage (L1, L2, L3)
 EMX3-xxxx-V4..... 200 VAC ~ 440 VAC (+10%)
 EMX3-xxxx-V7..... 380 VAC ~ 690 VAC (+10%) (in-line connection)
 EMX3-xxxx-V7..... 380 VAC ~ 600 VAC (+10%) (inside delta connection)
 Control Voltage (A1, A2, A3)..... 110 ~ 220 VAC (+10% / -15%)
 or 230 ~ 440 VAC (+10% / -15%)
 Mains Frequency..... 45 Hz to 66 Hz

Inputs

Inputs..... Active 24 VDC, 8 mA approx.
 Start (C23, C24)..... Normally open
 Stop (C31, C32)..... Normally closed
 Reset (C41, C42)..... Normally open or closed
 Programmable Inputs
 Input A (C53, C54)..... Normally open or closed
 Input B (C63, C64)..... Normally open or closed
 Motor Thermistor (B4, B5)
 PT100 RTD (B6, B7, B8)

Outputs

Relay outputs..... 10 A at 250VAC resistive
 5 A at 250 VAC, AC15 pf0.3
 Run Relay (23, 24)..... Normally Open
 Programmable Outputs
 Relay A (13, 14)..... Normally Open
 Relay B (31, 32, 34)..... Changeover
 Relay C (41, 42, 44)..... Changeover
 Analog Output(B10, B11)..... 0-20 mA or 4-20 mA
 24 VDC Output (P24, COM)..... 200mA

Environmental

Protection
 EMX3-0023B ~ EMX3-0105B..... IP20 & NEMA 1
 EMX3-0145B ~ EMX3-1600C..... IP00
 Operating temperature..... -10 °C ~ 60 °C
 Storage temprature..... -10 °C ~ 60 °C
 Humidity..... 5% to 95% Relative Humidity

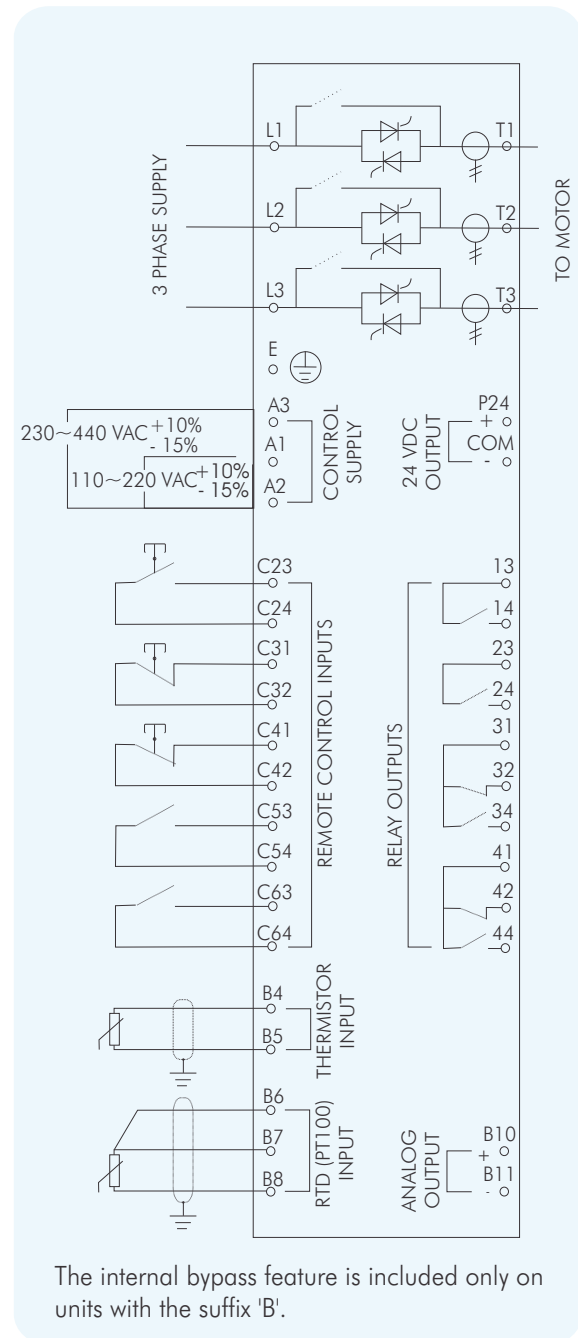

Note: Use semiconductor fuses at input

EMX3

Selection chart

Model	Light	Medium	Heavy	Severe
	AC53b 3.0-10:350	AC53b 3.5-15:345	AC53b 4.0-20:340	Ac53b 4.5-30:330
EMX3-0023B	23A	20A	17A	15A
EMX3-0043B	43A	40A	34A	29A
EMX3-0053B	53A	53A	46A	37A
	AC53b 3.0-10:590	AC53b 3.5-15:585	AC53b 4.0-20:580	AC53b 4.5-30:570
EMX3-0076B	76A	64A	55A	47A
EMX3-0097B	97A	82A	69A	58A
EMX3-0105B	105A	105A	95A	78A
EMX3-0145B	145A	123A	106A	90A
EMX3-0170B	170A	145A	121A	97A
EMX3-0220B	220A	210A	178A	148A
	AC53a 3.0-10:50-6	AC53a 3.5-15:50-6	AC53a 4.0-20:50-6	AC53a 4.5-30:50-6
EMX3-0255C	255A	222A	195A	171A
EMX3-0360C	360A	351A	303A	259A
EMX3-0430C	430A	413A	355A	301A
EMX3-0620C	620A	614A	515A	419A
EMX3-0650C	650A	629A	532A	437A
EMX3-0790C	790A	790A	694A	567A
EMX3-0930C	930A	930A	800A	644A
EMX3-1200C	1200A	1200A	1135A	983A
EMX3-1410C	1410A	1355A	1187A	1023A
EMX3-1600C	1600A	1600A	1433A	1227A

The above EMX3 current ratings are based on 300% starting current, 10 starts per hour, 10 seconds starting time and ambient temperature of 45°C.

AC53a Utilization Category Format

IMS2 Soft-Starter rating are detailed using the AC53a utilization code (for control of squirrel cage induction motor on 8-hour duty with on load current for start, acceleration and run) specified by IEC 60947-4-2.

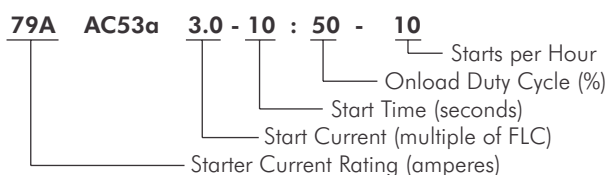

AC53b Utilization Category Format

CSX/CSXi Soft Starters rating are defined using the AC53b utilization code (for control of squirrel cage induction motors on intermittent duty) as per IEC 60947-4-2.

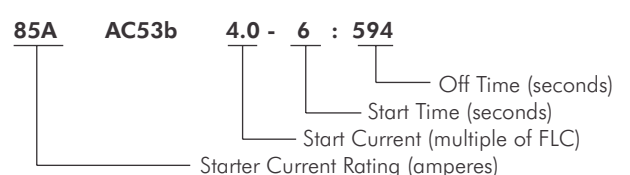

EMX3 Soft Starters

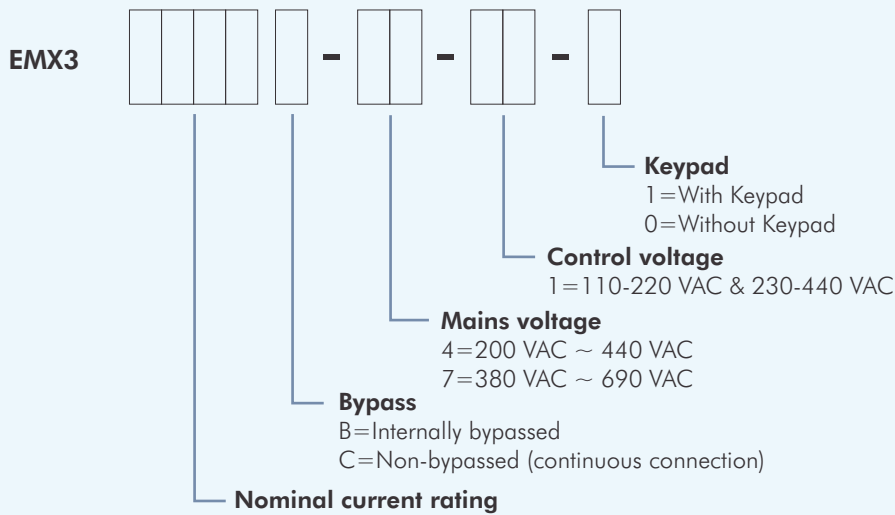

Power Range

Current ratings
23A
43A
53A
76A
97A
105A
145A
170A
220A
255A
360A
430A
620A
650A
790A
930A
1200A
1410A
1600A

Example: EMX3 0220B411

(EMX3 220A with Built-in Bypass and Keypad)

*Bypass inbuilt upto 220 A

DIMENSIONS AND WEIGHTS

Model	A	B	C	D	E	Weight
	mm (inches)	mm (inches)	mm (inches)	mm (inches)	mm (inches)	kg (lbs)
EMX3-0023B~ EMX3-0053B	156.4 (6.16)	124.0 (4.88)	294.6 (11.60)	278.0 (10.94)	192.2 (7.57)	3.2 (7.05)
EMX3-0076B					222.7 (8.77)	3.5 (7.22)
EMX3-0097B~ EMX3-0105B						4.8 (10.58)
EMX3-0145B~ EMX3-0220B	282 (11.10)	250 (9.84)	438 (17.24)	380 (14.96)	250 (9.84)	16 (35.27)
EMX3-0255C	390 (15.35)	20 (12.60)	417 (16.42)	400 (15.75)	281 (11.06)	25 (55.12)
EMX3-0360C~ EMX3-0930C	430 (16.93)	320 (12.60)	545 (21.46)	522 (20.55)	299 (11.77)	50.5 (111.33)
EMX3-1200C~ EMX3-1600C	574 (22.60)	500 (19.69)	750 (29.53)	727 (28.62)	361 (14.21)	136 (299.83)

For EMX3-0145B ~ EMX3-1600C, dimensions A & C are the unit footprint.
 Bus bars are not included as this dimension will vary with bus bar configuration.

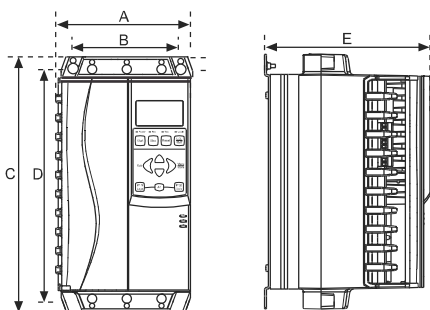

COMPACT DESIGN

The design of the EMX3 allows for multiple units to be mounted side by side, or in a bank of starters due to the flexibility in cabling options. Internally bypassed starters further reduce the overall size of your soft starter.

Accessories

Communication Modules

All the soft starters can be integrated into serial communication networks for remote monitoring and control. All communication interfaces have a compact physical form, designed to attach to the CSX and EMX3 series with very little extra space.

Device Net Interface

CAT No.	PIMDN01
Node address range	0 to 63
Data rate	125 kB, 250 kB, 500 kB

Profibus Interface

CAT No.	PIMPB01
Node address range	00 to 99
Data rate	9.6 kB/s ~ 12 MB/s

Modbus Interface

CAT No.	PIMMB01
Protocol	Modbus RTU, AP ASCII
Address range	0 to 31
Data rate (bps)	4800, 9600, 19200, 38400

USB interface

CAT No.	PIM-USB-01
Protocol	
CSX and CSXi	AP ASCII
EMX3	Binary
Address	20
Data Rate (bps)	9600

Input/Output Expansion Card

The Input/ Output expansion card provides two digital inputs, three relay outputs, one analog input and one analog output. No additional wiring is required to install the expansion card.

Inputs

Input C (C73, C74[Com])	Normally Open
Input D (C83, C74[Com])	Normally Open
Analog Input (B14[+], B13[Com])	0-10 V or 0-20 V (selectable)

Outputs

Relay D (51, 52)	Normally Closed
Relay D (63, 64)	Normally Open
Relay D (73, 74)	Normally Open
Analog Output (B12[+], B13[Com])	0-20 mA or 4-20 mA (selectable)

RTD and Ground Fault Protection Card

The RTD and Ground Fault Protection Card provides one ground fault input and six RTD inputs for use with PT100 temperature sensors.

RTD Input connection can be done in 2-wire, 3-wire or 4-wire configuration.

To use ground fault protection, a current transformer (1000:1 CT, Rating 5VA) must also be installed in all the three phases. For maximum protection, the CT must be installed on the input side of soft starter.

Specifications :

RTD accuracy

-20°C to 0°C	±2°C
0°C to +100°C	±0.5°C
+100°C to +150°C	±2°C

Selection of Right Starter

FEATURES	CSX	CSXi	EMX3
Starting			
Timed voltage ramp	✓		
Constant current		✓	✓
Current ramp		✓	✓
Torque control			
Kickstart			✓
XLR8 Adaptive acceleration			✓
Stopping			
Soft stop	✓	✓	✓
Pump stop			
XLR8 Adaptive acceleration			✓
Protection			
Mains frequency	✓	✓	✓
Phase sequence		✓	✓
Shorted SCR	✓	✓	✓
Motor overload (thermal model)		✓	✓
Instantaneous overcurrent			✓
Undercurrent			✓
Current imbalance		✓	✓
Motor thermistor		✓	✓
Excess start time		✓	✓
Power loss	✓	✓	✓
Auxiliary trip			✓
Human Interface			
Starter status LEDs	✓	✓	✓
Trip log and start counters			✓
Store/reload user settings			✓
Performance metering			✓
Large LCD screen			✓
Control Interface			
Programmable control inputs			✓
Programmable relay outputs		✓	✓
Analog output			✓
Serial port*	✓	✓	✓
Sundry			
Dual motor sets			✓
Emergency start			✓
Auto-stop			✓
Options & Accessories			
Device Net	✓	✓	✓
Modbus RTU	✓	✓	✓
Profibus	✓	✓	✓
PC Software	✓	✓	✓
Remote Operator	✓	✓	✓
Approvals			
CE	✓	✓	✓

*Optional

Selection of Right Starter

To receive the maximum benefit from soft starting, it is important to select the right starter for the situation.

The most important factors are the size of the motor and the type of application. Different applications have different starting characteristics, and applications can be grouped into generalised duty rating categories.

Typical Start Current Requirements - Application duty ratings

- Normal Duty: 300 - 350% FLC : 10 to 20 seconds
- Heavy Duty: 400% FLC : around 30 seconds
- Severe Duty: 450% FLC : around 50 seconds

	300%	350%	400%	450%		300%	350%	400%	450%
Agitator			•		Hydraulic Power Pack		•		
Atomiser			•		Mill				•
Bottle Washer	•				Mill - Ball				•
Bow Thruster		•			Mill - Hammer				•
Carding Machine		•			Mill - Roller				•
Centrifuge				•	Milliscreen		•		
Chipper				•	Mixer (High Viscosity)				•
Compressor - Centrifugal (Rotary)		•			Mixer (Low Viscosity)			•	
Compressor - Reciprocating (Loaded)				•	Palletiser				•
Compressor - Reciprocating (Unloaded)			•		Planer		•		
Compressor - Screw (Loaded)			•		Press		•		
Compressor - Screw (Unloaded)		•			Pump - Bore	•			
Conveyer - Horizontal (Loaded)		•			Pump - Centrifugal		•		
Conveyer - Horizontal (Unloaded)		•			Pump - Positive Displacement			•	
Conveyer - Vertical (Loaded)			•		Pump - Slurry				•
Conveyer - Vertical (Unloaded)		•			Pump - Submersible		•		
Conveyer - Belt				•	Pump - Vacuum		•		
Conveyer - Roller		•			Re-pulper		•		•
Conveyer - Screw			•		Rotary Table			•	
Crusher - Cone		•			Sander		•		
Crusher - Jaw				•	Saw - Bandsaw				•
Crusher - Rotary (Unloaded)		•			Saw - Circular		•		
Crusher - Vertical Impact		•			Screw Feed			•	
Debarker		•			Separator (Liquids)				•
Drilling Machine		•			Separator (Solids)			•	
Dryer				•	Shredder				•
Dust Collector		•			Slabber		•		
Edger		•			Slicer	•			
Escalator		•			Stirrer (Liquids)		•		
Fan - Axial (Damped)		•			Travelator		•		
Fan - Axial (Un-damped)				•	Tumbler			•	
Fan - Centrifugal (Damped)		•			Vibrating Screen			•	
Fan - Centrifugal (Un-damped)				•	Winch			•	
Fan - High Pressure				•	Wine Draw Machine (Hydraulic)		•		
Grinder		•							

Selecting the correct starter model

When you know the duty rating of the application, you can choose an appropriate soft starter. Select a starter which offers the features you want, and use the table below to ensure that the soft starter is appropriate for the application. Select a soft starter model which has a current rating at least equal to the motor's rated current, at the appropriate duty rating.

		Application duty		
		Normal	Heavy	Severe
Starter duty	CSX Series	✓		
	EMX3	✓	✓	✓

Selection of Semiconductor Fuse

Short circuit protection device (SCPD) is an integral part of any motor starter / motor starting solution. For traditional starters like DOL or Star delta starter HRC Fuse / MCCB is widely used. Soft starter is now being widely used for starting of various loads as a replacement of DOL/ Start Delta starter. However to ensure that semiconductor devices are protected in the event of short circuit, fast acting fuses or Semiconductor Fuses are used as SCPD.

Installation Guidelines for CSX / CSXi / EMX3 range for soft starters to achieve Type 2 coordination:

Type 2 protection requires that in the event of a short circuit on the output of a soft starter the fault must be cleared without risk of injury to personnel or damage to the soft starter.

Type 2 protection is achieved by using semiconductor fuses. These fuses must be able to carry motor start current and have a total clearing $I^2t < \text{the } I^2t \text{ of the soft starter SCRs.}$

Semiconductor fuses for Type 2 circuit protection are additional to HRC fuses or MCCBs that form part of the motor branch circuit protection.

The below mentioned charts specify the rating of the semiconductor fuse to be used along with the soft starter.

Table for selection of semiconductor fuse for CSX and CSXi series:

Model CSX & CSXi	SCR I ² t (A ² S)	Ferraz Fuse European/IEC Style (North American Style)	Bussmann Fuse Square Body (170M)	Bussmann Fuse British Style (BS88)
CSX-007	1150	6.6URD30xxxA0063 (A070URD30xxx0063)	170M-1314	63FE
CSX-015	8000	6.6URD30xxxA0125 (A070URD30xxx0125)	170M-1317	160FEE
CSX-018	10500	6.6URD30xxxA0160 (A070URD30xxx0160)	170M-1318	160FEE
CSX-022	15000	6.6URD30xxxA0160 (A070URD30xxx0160)	170M-1318	180FM
CSX-030	18000	6.6URD30xxxA0160 (A070URD30xxx0160)	170M-1319	180FM
CSX-037	51200	6.6URD30xxxA0250 (A070URD30xxx0250)	170M-1321	250FM
CSX-045	80000	6.6URD30xxxA0315 (A070URD30xxx0315)	170M-1321	250FM
CSX-055	97000	6.6URD30xxxA0315 (A070URD30xxx0315)	170M-1321	250FM
CSX-075	168000	6.6URD31xxxA0450 (A070URD31xxx0450)	170M-1322	500FMM
CSX-090	245000	6.6URD31xxxA0450 (A070URD31xxx0450)	170M-3022	500FMM
CSX-110	320000	6.6URD31xxxA0450 (A070URD31xxx0450)	170M-3022	500FMM

xxx = Blade Type. Contact Ferraz for options.

Selection of Semiconductor Fuse

Table for selection of semiconductor fuse for EMX3 series:

Model	SCR I ² t (A ² S)	Bussmann Fuse Square Body (170M)	Bussmann Fuse British Style (Bs88)	Ferraz Fuse (HSJ)	Ferraz Fuse European Style (PSC 690)	Ferraz Fuse N. American Style (PSC 690)
EMX3-0023B	1150	170M1314	63FE	HSJ40**	6.9URD30D11A0050	A070URD30XXX0063
EMX3-0043B	8000	170M1318	120FEE	HSJ60	6.9URD30D11A0125	A070URD30XXX0125
EMX3-0050B	10500	170M1318	200FEE	HSJ80**	6.9URD30D11A0125	A070URD30XXX0125
EMX3-0053B	15000	170M1318	200FEE	HSJ90**	6.9URD30D11A0125	A070URD30XXX0125
EMX3-0076B	15000	170M1319	200FEE	HSJ110**	6.9URD30D11A0200	A070URD30XXX0200
EMX3-0097B	51200	170M1321	280FM	HSJ150	6.9URD30D11A0200	A070URD30XXX0200
EMX3-0100B	80000	170M1321	280FM	HSJ175	6.9URD30D11A0200	A070URD30XXX0200
EMX3-0105B	125000	170M1321	280FM	HSJ225	6.9URD30D11A0315	A070URD30XXX0315
EMX3-0145B	125000	170M2621	280FM	HSJ250	6.9URD30D11A0315	A070URD30XXX0315
EMX3-0170B	320000	170M2621	450FMM	HSJ300	6.9URD30D11A0315	A070URD30XXX0315
EMX3-0200B	320000	170M2621	450FMM	HSJ350	6.9URD31D11A0450	A070URD30XXX0450
EMX3-0220B	320000	170M2621	450FMM	HSJ350	6.9URD31D11A0450	A070URD30XXX0450
EMX3-0255C	320000	170M2621	450FMM	-	6.9URD31D11A0450	A070URD30XXX0450
EMX3-0360C	238000	170M6010	-	HSJ400**	6.9URD33D11A0630	A070URD33XXX0630
EMX3-0380C	320000	170M6011	400FMM*	-	6.9URD33D11A0800	A070URD33XXX0700
EMX3-0430C	320000	170M6011	400FMM*	-	6.9URD33D11A0800	A070URD33XXX0700
EMX3-0620C	1200000	170M6015	630FMM*	-	6.9URD33D11A1000	A070URD33XXX1000
EMX3-0650C	1200000	170M6015	630FMM*	-	6.9URD33D11A1000	A070URD33XXX1000
EMX3-0790C	2530000	170M6017	-	-	6.6URD33D11A1250	A070URD33XXX1250
EMX3-0930C	4500000	170M6019	-	-	6.6URD33D11A1400	A070URD33XXX1400
EMX3-1200C	4500000	170M6019	-	-	6.9URD233PLAF1800	A065URD33XXX1800
EMX3-1410C	6480000	170M6021	-	-	6.9URD233PLAF2200	-
EMX3-1600C	12500000	170M6018*	-	-	6URD233PLAF2500	A050URD33XXX1400*

* Two parallel connected fuses required per phase.

** Two series connected fuses required per phase.

XXX Blade Type. Refer to Ferraz catalog for options.

WinStart software

L&T Electrical & Automation's WinStart software is used for selecting the right soft starter. The selection of the soft starter can be done on basis of calculation of Maximum FLC or type of connection, whether inline connection is used or inside delta, for both bypassed and non-bypassed combinations.

Following are the steps to be followed for selection of the soft starter:

1. Click on the desired soft starter to be selected.



2. Enter the application parameters as given in white fields. Based on these parameters, the recommended soft starter model is displayed.

White fields indicate data to be entered

Grey fields indicate data to be checked

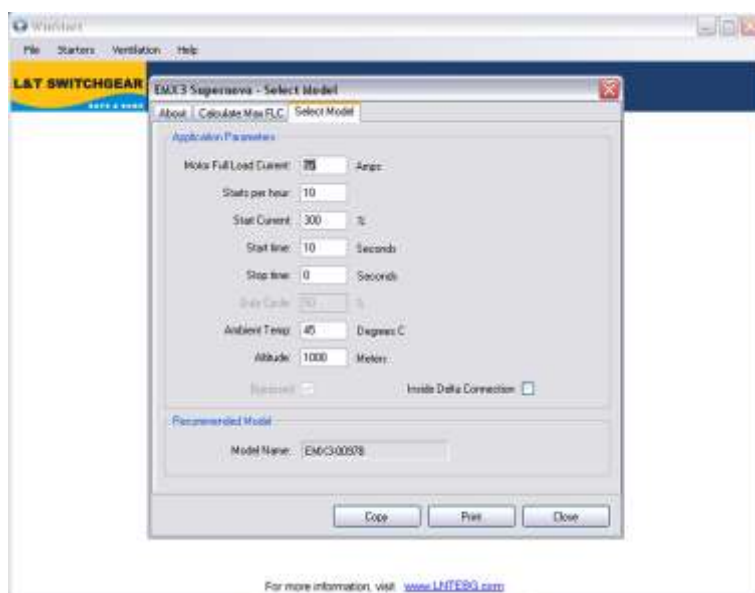

3. After selecting the soft starter, the full load current should not exceed the calculated value mentioned in Inline Max FLC. Also check the power dissipated in soft starter

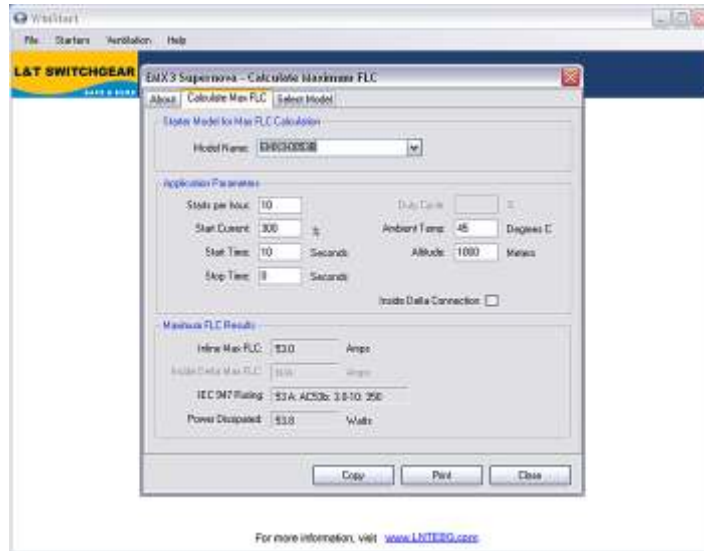

4. The temperature rise inside the cabinet in which the soft starter is installed can also be calculated. Provide the necessary dimensions, power dissipated (given by previous calculations) & maximum allowable temperature rise, to obtain the internal cabinet temperature rise & minimum cooling fan flow, which are displayed in ft³/min or m³/min.

* For IP54 enclosure, refer Frequently Asked Questions point no. 9.



Note:

After selecting the soft starter, you can click on Copy and paste the details of selection in any format, like notepad, word file etc.

Frequently Asked Questions

1. Power Factor Correction: can it be used with soft starters?

Individual power factor correction capacitors can be used with soft starters, provided that they are installed on the input side of the soft starter and switched in using a dedicated contact or when the motor is running at full speed. The contact or should be AC6 rated for the motor full load current.

Connecting power factor correction capacitors to the output of a soft starter will cause equipment failure due to severe over voltage. This over voltage is created by resonance between the inductance of the motor and the power factor capacitance.

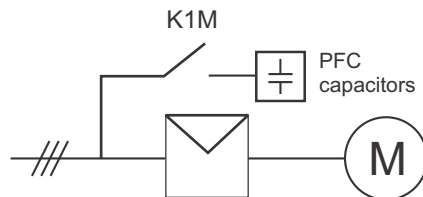

2. When and how should the Main Contactors be used?

Soft starters can be installed with or without a main contactor.

A main contactor:

- may be required to meet local electrical regulations.
 - provides physical isolation when the starter is not in use and in the event of a soft starter trip.
- Even in the off state SCRs do not offer a high degree of isolation due to leakage through the SCR and protection networks.
- protects the soft starter SCRs from severe overvoltage situations (eg lightning strikes).
- SCRs are most susceptible to overvoltage damage when in the off state. A main contactor disconnects the SCRs from the supply when the motor is not running, preventing possible damage.
- Main contactors should be AC3 rated for the motor FLC.

3. When and how should Bypass Contactors be used?

Bypass contactors bridge out a soft starter's SCRs when the motor is running at full speed. This eliminates heat dissipation from the SCRs during run state.

Some soft starters include built-in bypass contactors, others require an external bypass contactor.

Bypass contactors:

- allow soft starters to be installed in sealed enclosures
 - eliminate the cost of forced-air cabinet ventilation
 - save energy by eliminating SCR losses during run
- Bypass contactors should be AC1 rated for the motor FLC.

The AC1 rating is adequate because the bypass contactor does not carry start current or switch fault current.

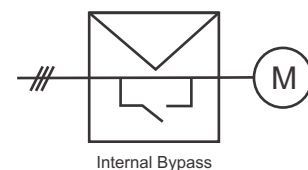
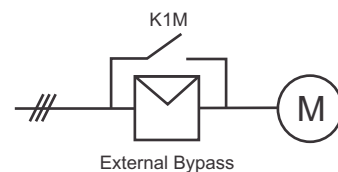

4. What is Inside Delta Connection and why should it be used ?

Inside delta connection (also called six-wire connection) places the soft starter SCRs in series with each motor winding. This means that the soft starter carries only phase current, not line current. This allows the soft starter to control a motor of larger than normal full load current.

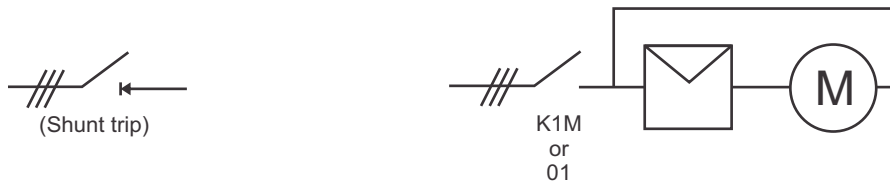

When using an inside delta connection, a main contactor or shunt trip MCCB must also be used to disconnect the motor and soft starter from the supply in the event of a trip.

Inside delta connection:

- Simplifies replacement of star/delta starters because the existing wiring can be used.
 - May reduce installation cost. Soft starter cost will be reduced but there are additional cabling and main contractor costs. The cost equation must be considered on an individual basis.
- Only motors that allow each end of all three motor windings to be connected separately can be controlled using the inside delta connection method.

Not all soft starters can be connected in inside delta.

5. Sequential Starting: Can one soft starter be used to separately control multiple motors?

Yes, one soft starter can control multiple motors in sequence. However, the control and wiring needs to be engineered for proper operation.

In order to use a soft starter in a sequential starting situation,

1. Each motor must have a separate:
 - main contactor
 - bypass contactor
 - overload protection
2. The soft starter must be suitably rated for the total start duty.

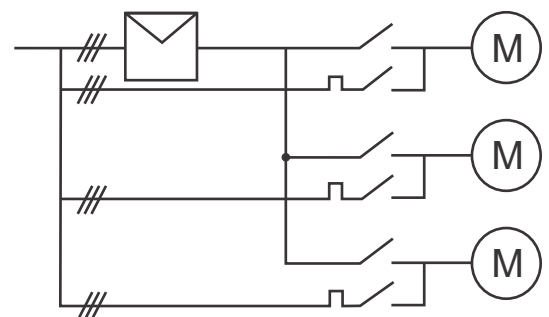

6. Can a star/delta starter be replaced with a soft starter?

Yes.

If the soft starter is capable of inside delta connection, simply connect it in place of the star/delta starter.

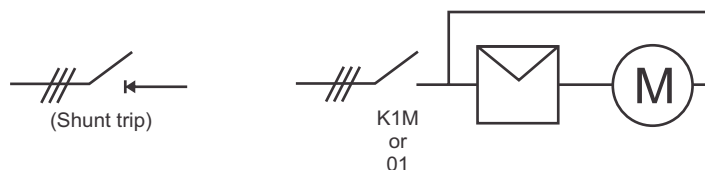

If the soft starter is not capable of inside delta connection, connect the delta connection to the output side of the soft starter.



Frequently Asked Questions

7. Can one soft starter be used to control multiple motors i.e. Parallel Starting?

Yes. The circuit configuration and soft starter selection depends on the application.

1. Each motor must have its own overload protection.

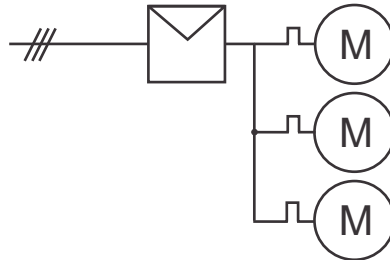

2. If the motors are the same size and are mechanically coupled, a constant current soft starter can be used.
3. If the motors are different sizes and/or the loads are not mechanically interlocked, a soft starter with a timed voltage ramp (TVR) start profile should be used.
4. The combined motor FLCs must not exceed the soft starter FLC.

8. Can soft starters control an already rotating motor (flying load)?

Yes, soft starters can start motors that are already rotating.

In general, the faster the motor is still rotating, the shorter the start time will be. If the motor is rotating in the reverse direction, it will be slowed to a standstill and then accelerate forwards.

No special wiring or soft starter setup is required.

9. How to calculate the rise in internal temperature for IP54 enclosure?

For any panel, the temperature rise can be reduced either by operating at lower ambient temperature, or by dissipating the excess heat, so that temperature rise is controlled. This condition depends upon the design of the model. By offering effective cooling methods, the excess heat generated by the equipments can be dissipated. Selection of the cooling methods can be decided based on the internal temperature rise inside the panel. The maximum internal temperature can be calculated using the following formula:

$$\text{Internal Temperature } (T_i) = \frac{P_d}{k \times S} + T_a$$

Where, P_d = Total power dissipated in the panel (in watts)

k = constant defined by the material used to manufacture the enclosure.

For painted sheet-steel enclosure, $k = 5.5 \text{ W/m}^2 \text{ }^\circ\text{C}$

S = effective surface area of the panel (in m^2)

T_a = Ambient temperature (in $^\circ\text{C}$)

Electrical Standard Products (ESP) Offices:

HEAD OFFICE

L&T Electrical & Automation
L&T Business Park,
Tower 'B' / 3rd Floor
Saki Vihar Road, Powai
Mumbai 400 072
Tel: 022-67053229
Fax: 022-67051112
e-mail: cic@LNTEBG.com

BRANCH OFFICES

L&T Electrical & Automation
501, Sakar Complex I
Opp. Gandhigram Rly. Station
Ashram Road
Ahmedabad 380 009
Tel: 079-66304006-11
Fax: 079-66304025
e-mail: esp-ahm@LNTEBG.com

L&T Electrical & Automation
M/s Larsen & Toubro Ltd
No 38, Cubbon Road
Bengaluru 560 001
Tel: 080-46136103 / 100
e-mail: esp-blr@LNTEBG.com

L&T Electrical & Automation
131/1, Zone II, Maharana Pratap Nagar
Bhopal 462 011
Tel: 0755-3080511 / 05 / 08 / 13 / 17 / 19
Fax: 0755-3080502
e-mail: esp-bho@LNTEBG.com

L&T Electrical & Automation
Plot No. 559, Annapurna Complex
Lewis Road
Bhubaneswar 751 014
Tel: 0674-6451342 / 2436690 / 2436696
Fax: 0674-2537309
e-mail: esp-bsr@LNTEBG.com

L&T Electrical & Automation
Aspire Towers, 4th Floor
Plot No. 55, Phase-I
Industrial & Business Park
Chandigarh-160 002
Tel: 0172-4646840 / 41 / 42 / 46 / 53
Fax: 0172-4646802
Email: esp-chd@LNTEBG.com

L&T Electrical & Automation
L&T Construction Campus
TC-1 Building, II Floor
Mount-Poonamallee Road
Manapakkam
Chennai 600 089
Tel: 044-2270 6800
Fax: 044-2270 6940
e-mail: esp-maa1@LNTEBG.com

L&T Electrical & Automation
67, Appuswamy Road, Post Bag 7156
Opp. Nirmala College
Coimbatore 641 045
Tel: 0422-4588120 / 1 / 5
Fax: 0422-2588148
e-mail: esp-cbe@LNTEBG.com

L&T Electrical & Automation
1&2, Vijay Park, Main Chakrata road
Opp: Anandam, Ballapur Chowk
Dehradun 248001
Tel: 9582252411

L&T Electrical & Automation
Khairasol, Degaul Avenue
Durgapur 713 212
Tel: 0343-2540448 / 2540449 / 2540443
Fax: 0343-2540442
e-mail: esp-dgp@LNTEBG.com

L&T Electrical & Automation
5, Milanpur Road, Bamuni Maidan
Guwahati 781 021
Tel: +91 8876554417
e-mail: esp-ghy@LNTEBG.com

L&T Electrical & Automation
II Floor, Vasantha Chambers
5-10-173, Fateh Maidan Road
Hyderabad 500 004
Tel: 040-67015052
Fax: 040-23296468
e-mail: esp-hyd@LNTEBG.com

L&T Electrical & Automation
Monarch Building, 1st Floor
D-236 & 237, Amrapali Marg
VaiShali Nagar
Jaipur 302 021
Tel: 0141-4385914 to 18
Fax: 0141-4385925
e-mail: esp-jai@LNTEBG.com

L&T Electrical & Automation
Akashdeep Plaza, 2nd Floor
P. O. Golmuri
Jamshedpur 831 003
Jharkhand
Tel: 0657-2312205 / 38
Fax: 0657-2341250
e-mail: esp-jam@LNTEBG.com

L&T Electrical & Automation
Skybright Bldg; M. G. Road
Ravipuram Junction, Ernakulam
Kochi 682 016
Tel: 0484-4409420 / 4 / 5 / 7
Fax: 0484-4409426
e-mail: esp-cok@LNTEBG.com

L&T Electrical & Automation
3-B, Shakespeare Sarani
Kolkata 700 071
Tel: 033-42005982
Fax: 033-22821025 / 7587
e-mail: esp-ccu@LNTEBG.com

L&T Electrical & Automation
A28, Indira Nagar, Faizabad Road
Lucknow 226 016
Tel: 0522-4929905 / 04
Fax: 0522-2311671
e-mail: esp-lko@LNTEBG.com

L&T Electrical & Automation
No: 73, Karpaga Nagar, 8th Street
K. Pudur
Madurai 625007
Tel: 0452-2567405 / 2561068 / 2561657
Fax: 0452-2567552
e-mail: esp-mdu@LNTEBG.com

L&T Electrical & Automation
L&T Business Park, Tower 'B' / 3rd Floor
Saki Vihar Road, Powai
Mumbai 400 072
Tel: 022-67052874 / 2737 / 1156
Fax: 022-67051112
e-mail: esp-bom@LNTEBG.com

L&T Electrical & Automation
Unnati Building, 2nd Floor
Automation Campus
A-600, TTC Industrial area
Shil-Mahape road, Mahape
Navi Mumbai - 400710

L&T Electrical & Automation
12, Shivaji Nagar
North Ambajhari Road
Nagpur 440 010
Tel: 0712-2260012 / 6606421
Fax: 2260030 / 6606434
e-mail: esp-nag@LNTEBG.com

L&T Electrical & Automation
32, Shivaji Marg
P. O. Box 6223
New Delhi 110 015
Tel: 011-41419514 / 5 / 6
Fax: 011-41419600
e-mail: esp-del@LNTEBG.com

L&T Electrical & Automation
Grand Chandra, 2nd Floor
Fraser Road
Opposite Doordarshan Kendra
Patna 800001
Tel: 8102440613
e-mail: esp-patna@LNTEBG.com

L&T Electrical & Automation
L&T House
P. O. Box 119
191/1, Dhole Patil Road
Pune 411 001
Tel: 020-48544395 / 48544279
e-mail: esp-pnq@LNTEBG.com

L&T Electrical & Automation
Crystal Tower,
4th Floor, G. E. Road
Telibandha
Raipur - 492 006
Tel: 0771-4283214
e-mail: esp-raipur@LNTEBG.com

L&T Electrical & Automation
3rd Floor
Vishwakarma Chambers
Majura Gate, Ring Road
Surat 395 002
Tel: 0261-2473726
Fax: 0261-2477078
e-mail: esp-sur@LNTEBG.com

L&T Electrical & Automation
Radhadaya Complex
Old Padra Road
Near Charotar Society
Vadodara 390 007
Tel: 0265-6613610 / 1 / 2
Fax: 0265-2336184
e-mail: esp-bar@LNTEBG.com

L&T Electrical & Automation
Door No. 49-38-14/3/2, 1st floor,
NGGO's Colony, Akkayyapalem,
Visakhapatnam - 530 016
Tel: 0891-2791126 / 2711125
Fax: 0891-2791100
e-mail: esp-viz@LNTEBG.com

Product improvement is a continuous process. For the latest information and special applications, please contact any of our offices listed here. Product photographs shown for representative purpose only.



L&T Electrical & Automation, Electrical Standard Products

L&T Business Park, TC-2, Tower B, 3rd Floor, Gate No. 5, Saki Vihar Road, Powai,
Mumbai - 400 072, INDIA www.Lntebg.com

Customer Interaction Center (CIC)

BSNL / MTNL (toll-free): 1800 233 5858 Reliance (toll-free): 1800 200 5858
Tel: 022 6774 5858 Email: cic@Lntebg.com Web: www.Lntebg.com